

## Voltage Transducer LV 100/SP47

For the electronic measurement of voltages : DC, AC, pulsed..., with a galvanic isolation between the primary circuit (high voltage) and the secondary circuit (electronic circuit).



$$I_{PN} = 10 \text{ mA}$$

$$V_{PN} = 100 \dots 2500 \text{ V}$$

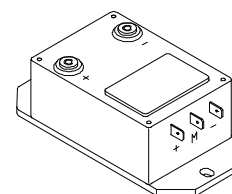

### Electrical data

$I_{PN}$	Primary nominal r.m.s. current	10	mA		
$I_P$	Primary current, measuring range	0 .. $\pm 20$	mA		
$R_M$	Measuring resistance	$R_{Mmin}$	$R_{Mmax}$		
				with $\pm 12 \text{ V}$	@ $\pm 10 \text{ mA}_{max}$
		@ $\pm 20 \text{ mA}_{max}$	0	40	$\Omega$
	with $\pm 18 \text{ V}$	@ $\pm 10 \text{ mA}_{max}$	80	250	$\Omega$
	@ $\pm 20 \text{ mA}_{max}$	80	90	$\Omega$	
$I_{SN}$	Secondary nominal r.m.s. current	50	mA		
$K_N$	Conversion ratio	10000 : 2000			
$V_C$	Supply voltage ( $\pm 5 \%$ )	$\pm 12 \dots 18$	V		
$I_C$	Current consumption	25 (@ $\pm 18 \text{ V}$ ) + $I_S$	mA		
$V_d$	R.m.s. voltage for AC isolation test, 50 Hz, 1 mn	9	kV		

### Accuracy - Dynamic performance data

$X_G$	Overall Accuracy @ $I_{PN}$ , $T_A = 25^\circ\text{C}$	$\pm 0.7$	%
$\mathcal{E}_L$	Linearity error	$< 0.1$	%
$I_O$	Offset current @ $I_P = 0$ , $T_A = 25^\circ\text{C}$	Typ	$\pm 0.3$ mA
		Max	$\pm 0.3$ mA
$I_{OT}$	Thermal drift of $I_O$	- 40 $^\circ\text{C}$ .. + 85 $^\circ\text{C}$	$\pm 0.6$ mA
		- 25 $^\circ\text{C}$ .. + 70 $^\circ\text{C}$	$\pm 0.4$ mA
$t_r$	Response time <sup>1)</sup> @ 90 % of $V_{PN}$	20 .. 100	$\mu\text{s}$

### General data

$T_A$	Ambient operating temperature	- 40 .. + 85	$^\circ\text{C}$
$T_S$	Ambient storage temperature	- 45 .. + 90	$^\circ\text{C}$
$R_P$	Primary coil resistance @ $T_A = 85^\circ\text{C}$	2000	$\Omega$
$R_S$	Secondary coil resistance @ $T_A = 85^\circ\text{C}$	63	$\Omega$
$m$	Mass	460	g
	Standards	EN 50155 (95.11.01)	

Note : <sup>1)</sup> L/R constant, produced by the resistance and inductance of the primary circuit.

### Features

- Closed loop (compensated) voltage transducer using the Hall effect
- Insulated plastic case recognized according to UL 94-V0.

### Principle of use

- For voltage measurements, a current proportional to the measured voltage must be collected through an external resistor  $R_1$  which is selected by the user and installed in series with the primary circuit of the transducer.

### Special features

- $V_C = \pm 12 \dots 18 (\pm 5\%) \text{ V}$
- $V_d = 9 \text{ kV}$
- $T_A = - 40^\circ\text{C} \dots + 85^\circ\text{C}$
- Railway equipment.

### Advantages

- Excellent accuracy
- Very good linearity
- Low thermal drift
- Low response time
- High bandwidth
- High immunity to external interference
- Low disturbance in common mode.

### Applications

- AC variable speed drives and servo motor drives
- Static converters for DC motor drives
- Battery supplied applications
- Uninterruptible Power Supplies (UPS)
- Power supplies for welding applications.

## Dimensions LV 100/SP47 (in mm. 1 mm = 0.0394 inch)

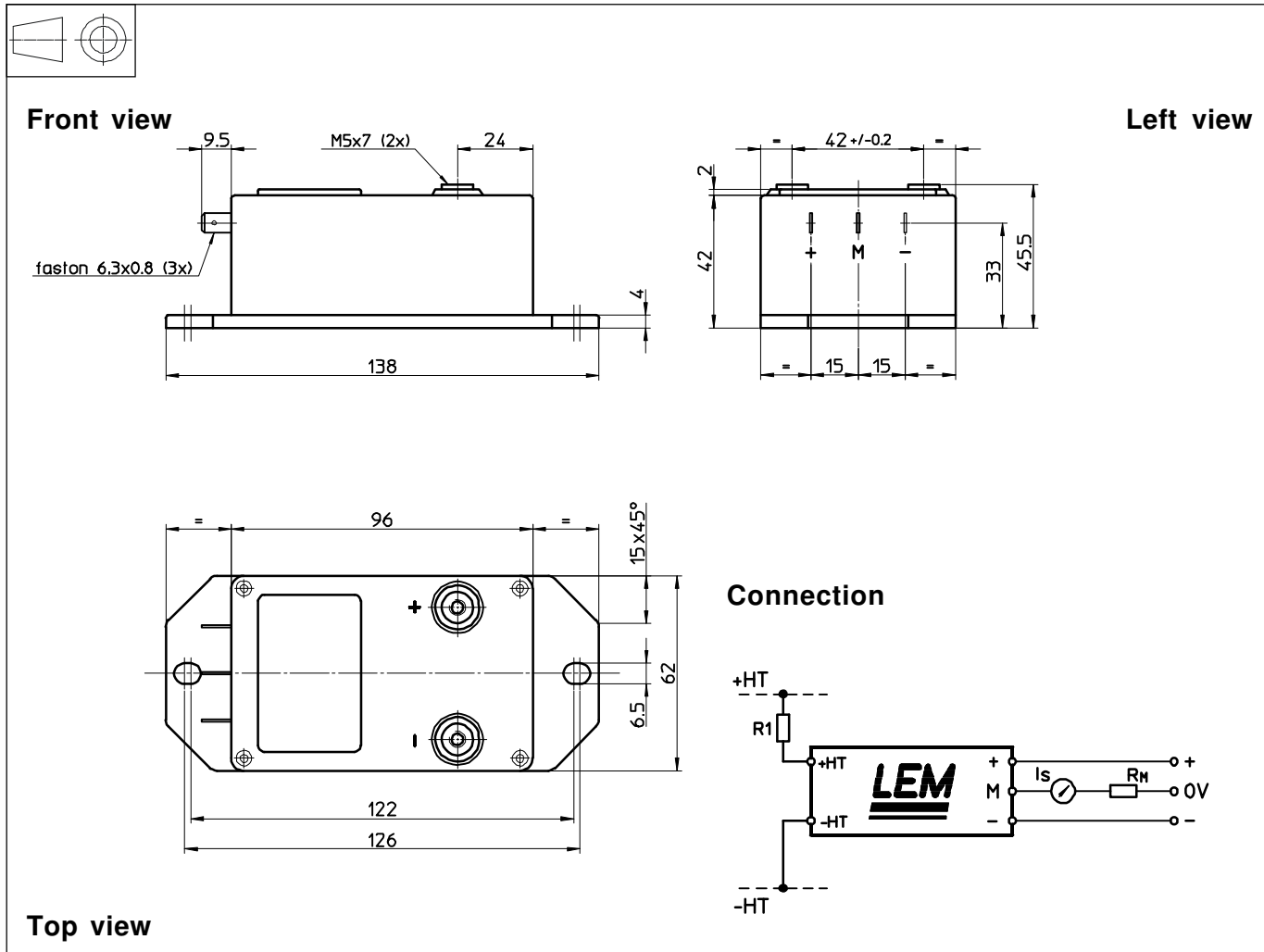

### Mechanical characteristics

- General tolerance  $\pm 0.3$  mm
- Transducer fastening 2 holes  $\varnothing 6.5$  mm  
2 M6 steel screws  
Recommended fastening torque 5 Nm or 3.69 Lb - Ft.
- Connection of primary M5 screw terminals  
Recommended fastening torque 2.2 Nm or 1.62 Lb - Ft.
- Connection of secondary Faston 6.3 x 0.8 mm

### Remark

- $I_s$  is positive when  $V_p$  is applied on terminal +HT.

### Instructions for use of the voltage transducer model LV 100/SP47

Primary resistor  $R_1$  : the transducer's optimum accuracy is obtained at the nominal primary current. As far as possible,  $R_1$  should be calculated so that the nominal voltage to be measured corresponds to a primary current of 10 mA.

Example: Voltage to be measured  $V_{PN} = 1000$  V

a)  $R_1 = 100$  k $\Omega$ / 40 W,  $I_p = 10$  mA Accuracy =  $\pm 0.7$  % of  $V_{PN}$  (@  $T_A = +25^\circ\text{C}$ )

b)  $R_1 = 400$  k $\Omega$ / 5 W,  $I_p = 2.5$  mA Accuracy =  $\pm 2.5$  % of  $V_{PN}$  (@  $T_A = +25^\circ\text{C}$ )

Operating range (recommended) : taking into account the resistance of the primary windings (which must remain low compared to  $R_1$ , in order to keep thermal deviation as low as possible) and the isolation, this transducer is suitable for measuring nominal voltages from 100 to 2500 V.

LEM reserves the right to carry out modifications on its transducers, in order to improve them, without previous notice.