



Helping Customers Innovate, Improve & Grow



VM-840

Description

Vectron's VM-840 Clock Oscillator is the next generation silicon MEMS based stabilized square wave generator with a CMOS output, operating off a 1.8, 2.5 or 3.3V supply.

The VM-840 uses an internal compensation scheme to improve temperature stability which produces temperature performance equivalent to quartz based products.

Features

- Short Lead Time
- Compact QFN Package
- Low Power
- +1.8V, +2.5V, or +3.3V Operation
- CMOS Output
- Output Frequencies to 150 MHz
- Enable/Disable for Board Test and Debug
- -20/70°C or -40/85°C Operating Temperature
- Industry Standard 2.5 x 2.0 SMD Footprint
- Product is Compliant to RoHS Directive and Fully Compatible with Lead Free Assembly

Applications

- Portable Media Players
- Consumer Electronic Applications
- Printers
- Camera's
- Low Profile Applications
- Computers & Peripherals

Specifications

Table 1. Electrical Performance

Parameter	Symbol	Min	Typical	Maximum	Units
Frequency	f_o	1.000		150.000	MHz
Stability ¹ (ordering option)	$\Delta f/f_o$	±25, ±50, ±100			ppm
Operating Temperature (ordering option)	T_{OP}	-20/70 or -40/85			°C
Operating Supply Voltage ² (ordering option)	V_{DD}	1.65	1.8	1.95	V
		2.3	2.5	2.7	V
		3.0	3.3	3.6	V
Supply Current, Output Enabled	I_{DD}	1 to 40MHz	3	6	mA
		40.01 to 80MHz	4	8	mA
		80.01 to 125MHz	5	10	mA
		125.01 to 150MHz	6	12	mA
Supply Current, Output Disabled	I_{DD}			1	uA
Output Logic Levels	V_{OH} V_{OL}	0.8* V_{DD}		0.2* V_{DD}	V
					V
Output Load		≥10Kohm ≤15pf			
Output Rise/Fall Time ³	t_R t_F		1.3	3	ns
			1.3	3	ns
Duty Cycle ⁴	SYM			45/55	%
Period Jitter ⁵ , RMS, 80MHz Output Peak-Peak			9		ps
			75		ps
Start-up Time	T_{SU}		3	10	ms
Enable/Disable ⁶	V_{IH} V_{IL}	0.75* V_{DD}		0.25* V_{DD}	V
					V

- 1] Stability includes initial accuracy, temperature and aging.
- 2] A 0.01uF and a 0.1uF capacitor should be located as close to the supply as possible (to ground) is recommended.
- 3] Figure 2 defines these parameters. Figure 1 illustrates the operating conditions under which these parameters are tested and specified.
- 4] Duty Cycle is measured defined as On Time/Period.
- 5] Measured using a Wavecrest SIA3300C, 90K samples
- 6] Output will be active if Enable/Disable is left open.

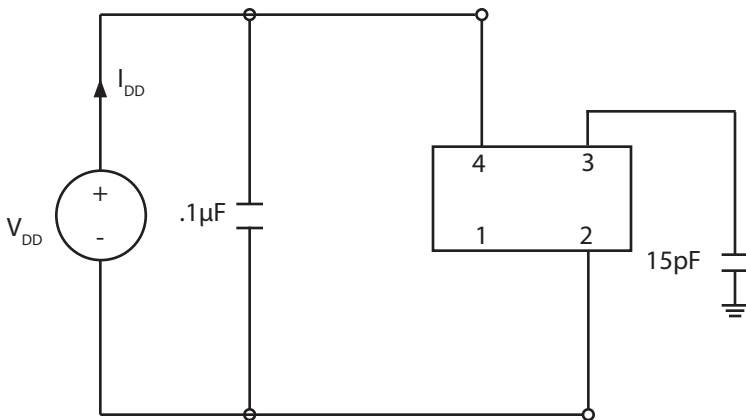

Fig 1: Test Circuit

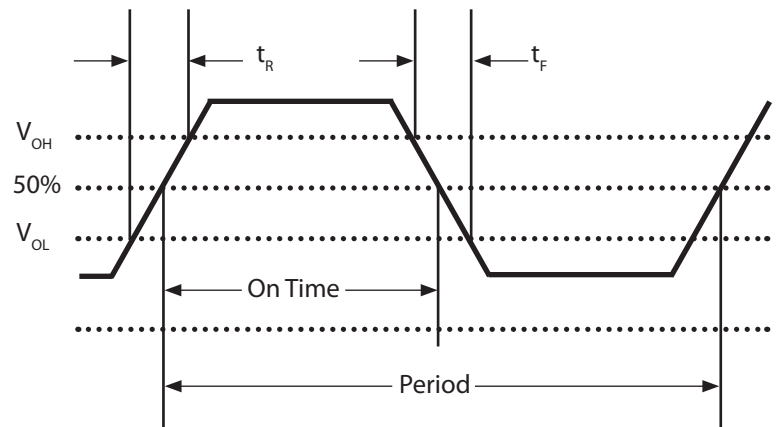

Fig 2: Output Waveform

Table 2. Absolute Maximum Ratings

Parameter	Symbol	Ratings	Unit
Power Supply	V_{DD}	-0.3 to +4.0	V
CMOS Input Voltage	E/D	-0.3 to ($V_{DD} + 0.3$)	V
Junction Temperature	T_J	150	°C
Storage Temperature	T_{STR}	-55 to 125	°C
Soldering Temperature / Duration	T_{PEAK} / t_p	260 / 40	°C / sec

Enable/Disable Functional Description

Under normal operation the E/D is set to a logic high state or logic low state. When E/D is set to a logic low, the oscillator stops and the output is in a high impedance state. This helps reduce power consumption as well as facilitating board testing and troubleshooting. When E/D is set to a logic high state, the oscillator produces an output. Leaving the Enable/Disable pin open results in an active state with an output frequency.

Outline Drawing

Suggested Pad Layout

Units: mm (inches)

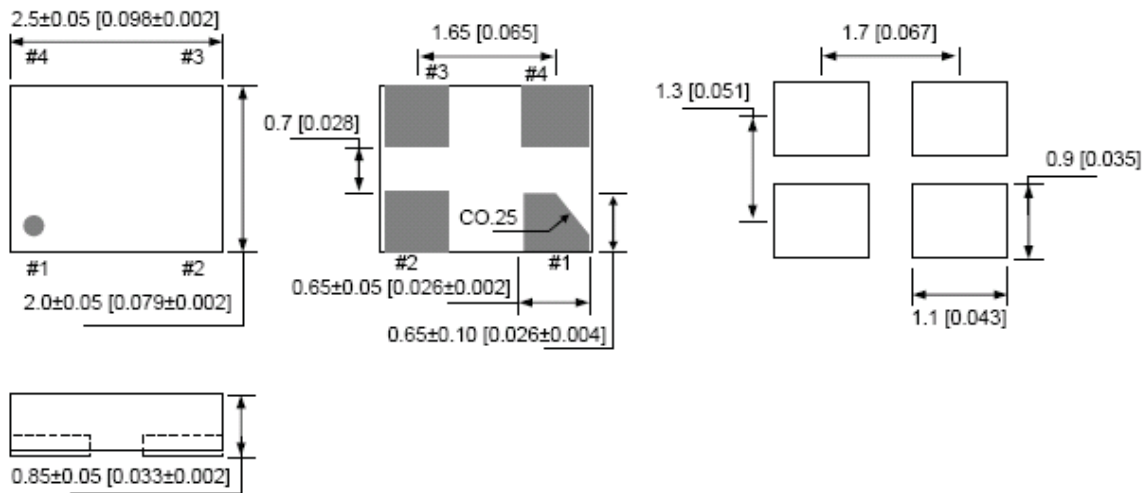

Contact Pads are
Gold flash (0.003 μm min) over
Palladium (0.01-0.15 μm) over
Nickel (0.508-2.032 μm)

Figure 3

Table 3. Pin Out

Pin	Symbol	Function
1	E/D	Enable/Disable
2	GND	Electrical Ground
3	f_o	Output Frequency
4	V_{DD}	Supply Voltage

Reliability

Table 4. Environmental Compliance

Parameter	Conditions
Mechanical Shock	MIL-STD-202, Method 2002
Mechanical Vibration	MIL-STD-883, Method 2007
Temperature Cycle	MIL-STD-883, Method 1010
Gross and Fine Leak	MIL-STD-883, Method 1014
Resistance to Solvents	MIL-STD-202, Method 215
Moisture Sensitivity Level	MSL1

Handling Precautions

Although ESD protection circuitry has been designed into the VM-840, proper precautions should be taken when handling and mounting. VI employs a Human Body Model and a Charged-Device Model (CDM) for ESD susceptibility testing and design protection evaluation. ESD thresholds are dependent on the circuit parameters used to define the model.

Table 5. ESD Ratings

Model	Minimum
Human Body Model	2000V
Charged Device Model	500V
Machine Model	200 V

Suggested IR Profile

Devices are built using lead free epoxy and can also be subjected to standard lead free IR reflow conditions. Figure 6 shows max temperatures and lower temperatures can also be used e.g. peak temperature of 220C.

Table 6. Reflow Profile

Parameter	Symbol	Value
PreHeat Time Ts-min Ts-max	t_s	60 sec Min, 260 sec Max 150°C 200°C
Ramp Up	R_{UP}	3 °C/sec Max
Time Above 217 °C	t_L	60 sec Min, 150 sec Max
Peak Temperature	t_p	255-260°C
Time To Peak Temperature	$T_{25C\ to\ Peak}$	480 sec Max
Time at Peak Temperature	t_p	20 sec Max
Ramp Down	R_{DN}	6 °C/sec Max

Solderprofile:

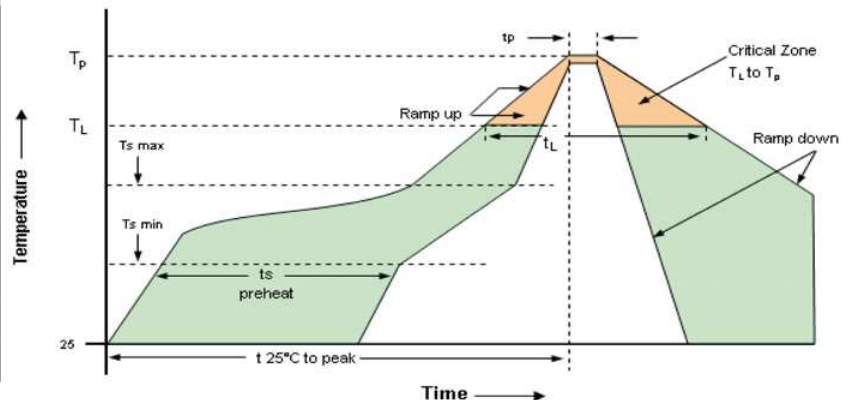

Figure 4

Ordering Information

Standard Frequencies (MHz)									
2.000	3.686	4.000	4.032	4.9152	5.000	6.000	7.3728	7.680	8.000
9.216	9.600	10.000	12.000	12.500	12.729	14.31818	14.746	16.000	16.128
17.000	20.000	21.000	21.500	22.000	23.000	24.000	25.000	26.000	27.000
29.4912	30.000	32.000	33.000	33.333	36.000	37.500	40.000	42.500	45.000
48.000	50.000	55.000	56.448	58.320	60.000	64.000	66.000	66.666	72.000
75.000	80.000	83.333	84.000	95.000	100.000	110.000	112.500	114.000	115.200
116.640	125.000	127.872							

Other Frequencies Available Upon Request.

VM-840-EAE-KANN- xxMxxxxxxxxx

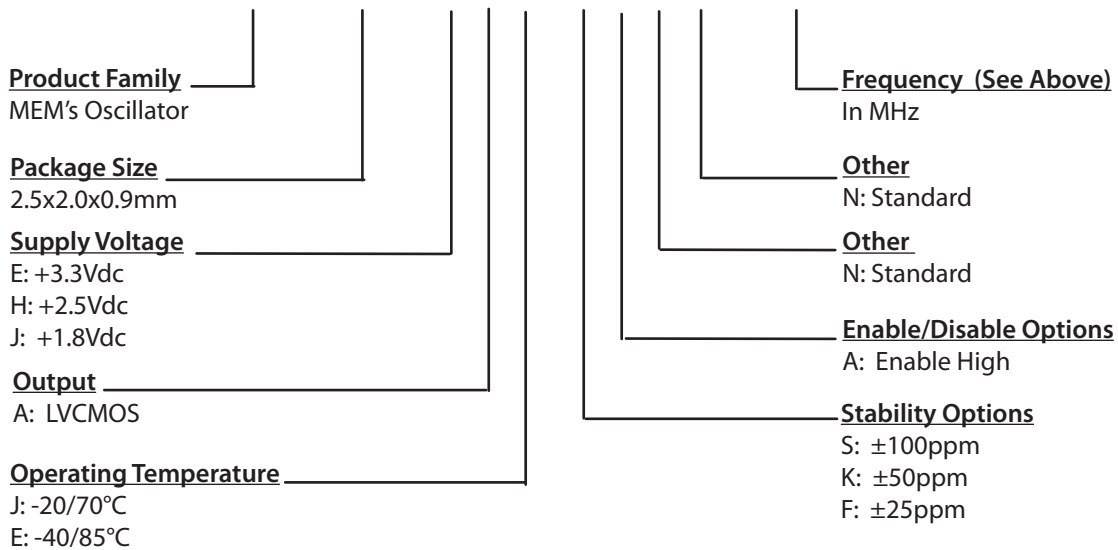

Example: VM-840-EAE-KANN-125M000000 = 2.5x2.0, +3.3V, LVCMOS output, ±50ppm over -40/85°C with a 125.000MHz output

For Additional Information, Please Contact

USA:

Vectron International
267 Lowell Road
Hudson, NH 03051
Tel: 1.888.328.7661
Fax: 1.888.329.8328

Europe:

Vectron International
Landstrasse, D-74924
Neckarbischofsheim, Germany
Tel: +49 (0) 3328.4784.17
Fax: +49 (0) 3328.4784.30

Asia:

Vectron International
1F-2F, No 8 Workshop, No 308 Fenju Road
WaiGaoQiao Free Trade Zone
Pudong, Shanghai, China 200131
Tel: 86.21.5048.0777
Fax: 86.21.5048.1881

Disclaimer

Vectron International reserves the right to make changes to the product(s) and/or information contained herein without notice. No liability is assumed as a result of their use or application. No rights under any patent accompany the sale of any such product(s) or information.

Rev: 9/22/2009