



Helping Customers Innovate, Improve & Grow



PX-990

Features

- Ultra low Phase Noise
- Ultra low G-Sensitivity
- Vibration hardened
- Tight Tolerances

Applications

- Vibration Environment
- Airborne and Military Equipment
- Portable Equipment
- Radar

Frequency Range
Standard Frequencies

60 MHz – 120 MHz
120 MHz

Performance Specifications

Frequency Stabilities ¹						
Parameter	Min	Typical	Max	Units	Condition	Options ³
vs. operating temperature range (referenced to nominal frequency)	-15.0		+15.0	ppm	-20 to +70°C	
	-25.0		+25.0	ppm	-40 to +85°C	
Initial tolerance	-15.0		+15.0	ppm	25°C V _s ±5% static Load ±10% static after 30 days of operation after 30 days of operation	
vs. supply voltage change	-0.1		+0.1	ppm		
vs. load change	-0.1		+0.1	ppm		
vs. aging / 1 year	-1.0		+1.0	ppm		
vs. aging / 10 years	-3.0		+3.0	ppm		

Performance Specifications

Supply Voltage (Vs)						
Parameter	Min	Typical	Max	Units	Condition	
Supply voltage (standard)	14.25	15	15.75	VDC		
Current consumption			100	mA		
RF Output						
Signal [standard]	Sinewave				50 Ω load	
Load	45	50	55	Ohm		
Output Power	10	13	16	dBm	50 Ω load	
Harmonics			-30	dBc	50 Ω load	
Spurious			-80	dBc	50 Ω load	
Additional Parameters						
Phase Noise ²		-90		dBc/Hz	10 Hz	@ 120 MHz 13 dBm sinewave no vibration
		-125		dBc/Hz	100 Hz	
		-153		dBc/Hz	1 kHz	
		-167		dBc/Hz	10 kHz	
		-173		dBc/Hz	100 kHz	
		-175		dBc/Hz	1 MHz	
G-Sensitivity		0.5		ppb/g	without shock absorbers ³	
G-Sensitivity			1	ppb/g	optional without shock absorbers ³	
G-Sensitivity			0.5	ppb/g	optional without shock absorbers ³	
Weight		55	75	g		
Processing & Packing	Handling & Processing Note					
Additional Environmental Conditions						
Random Vibration	RTCA/DO-160 D, Section 8, Category R or R2 curve C and C1					
Shock	MIL-STD-202G; Method 213B; 15 g / 20 ms					
Solderability	JEDEC J-STD-002 non RoHS compliant					
Solvent Resistance	non-washable device					
Absolute Maximum Ratings						
Supply voltage (Vs)			16.0	V		
Output Load	45		55	Ω		
Operable Temperature Range	-40		+85	°C		
Storage Temperature Range	-55		+105	°C		

Outline Drawing / Enclosure

Parameter	Min	Typical	Max	Units	Condition
G295 including vibration isolators. Mechanical resonance frequency	35		110	Hz	Please specify vibration profile and phase noise max values under vibration

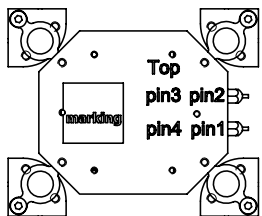
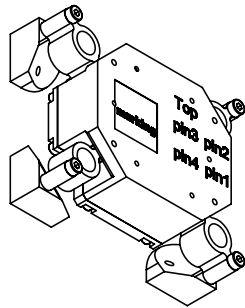
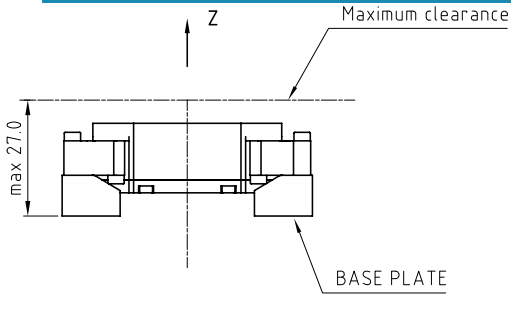

Dimensions in mm

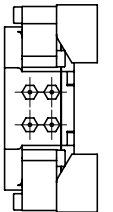
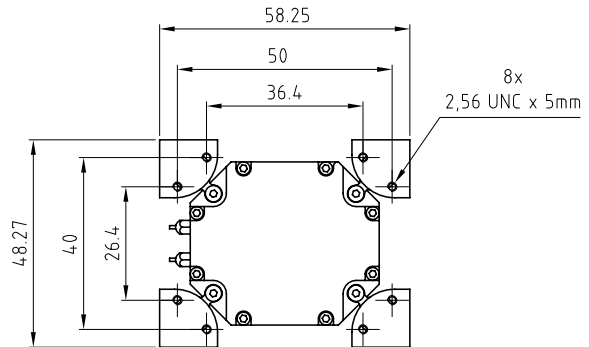
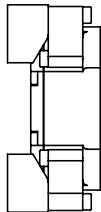

Parameter	Min	Typical	Max	Units	Condition
G313 without vibration isolators.					Option please specify vibration profile and phase noise max values under vibration

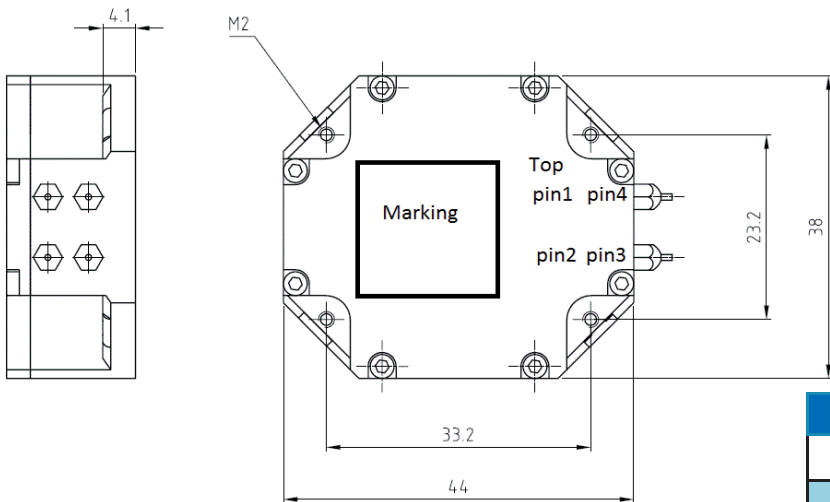
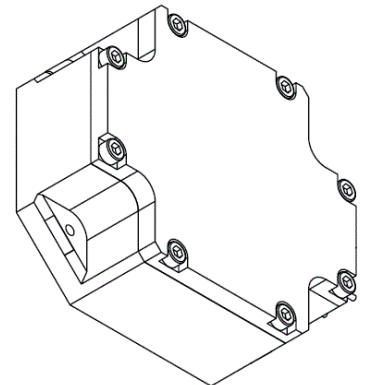
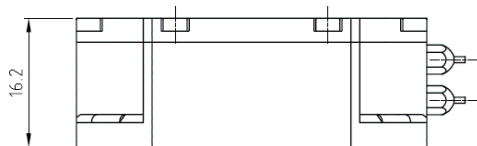

Dimensions in mm



Pin Connections	
1	N.C.
2	Supply Voltage (Vs)
3	RF-Output
4	Ground (Case)

Typical Phase Noise @ 120 MHz without vibration

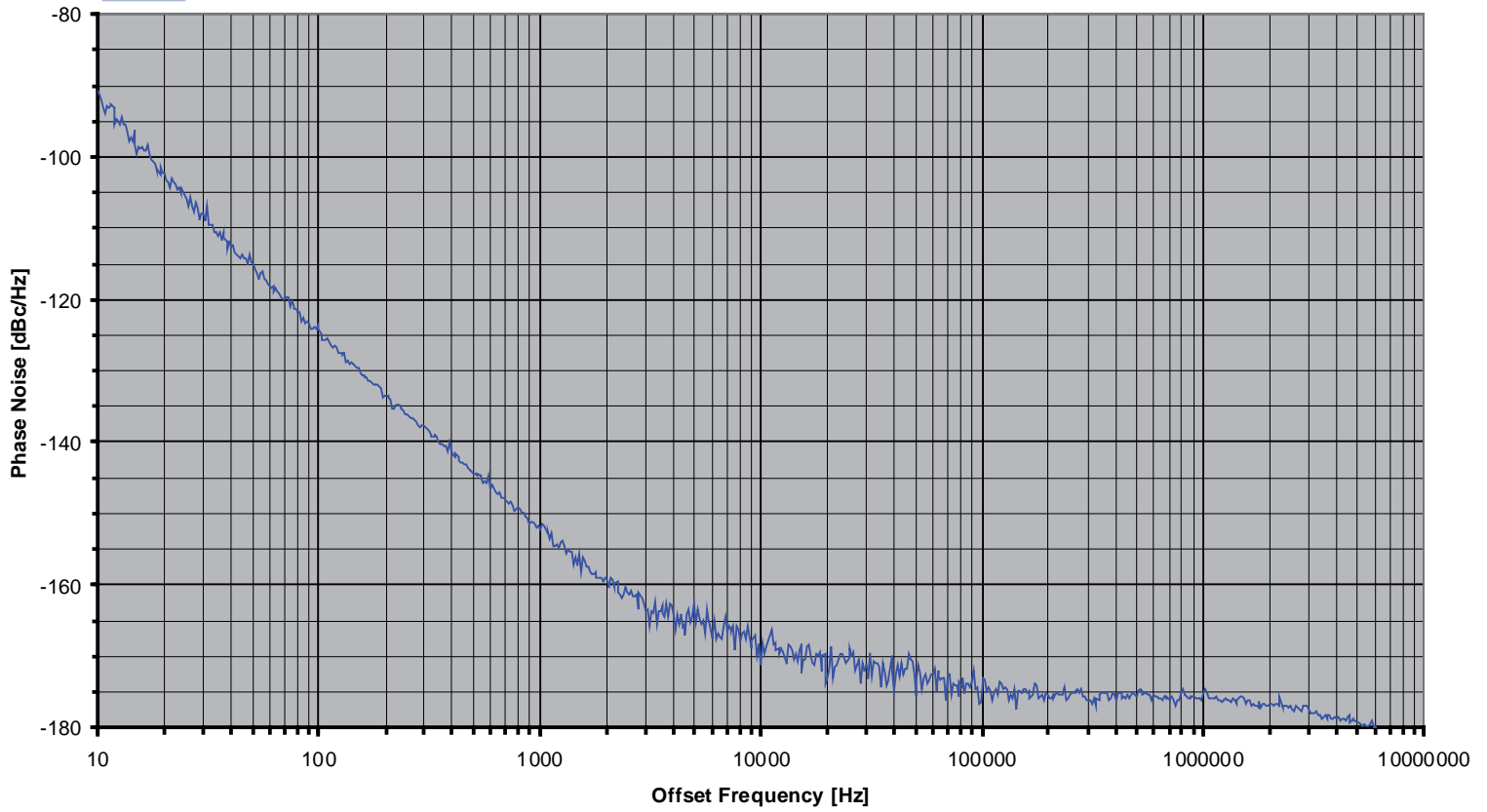

Typical G-Sensitivity @120 MHz without shock absorber

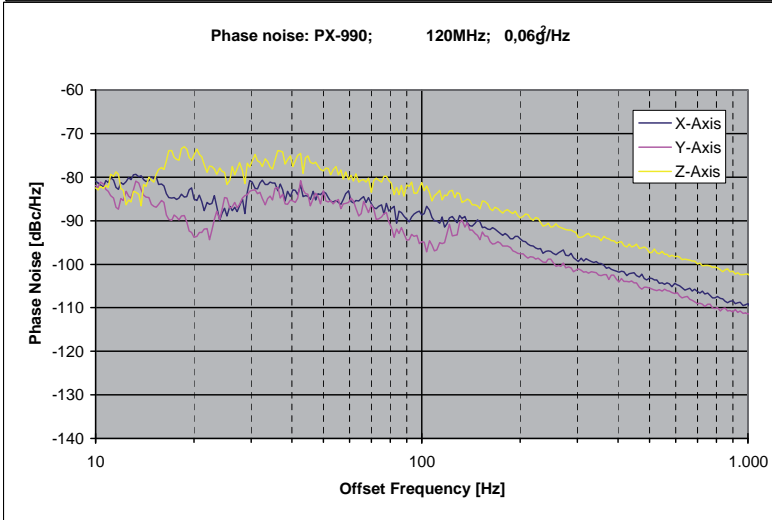
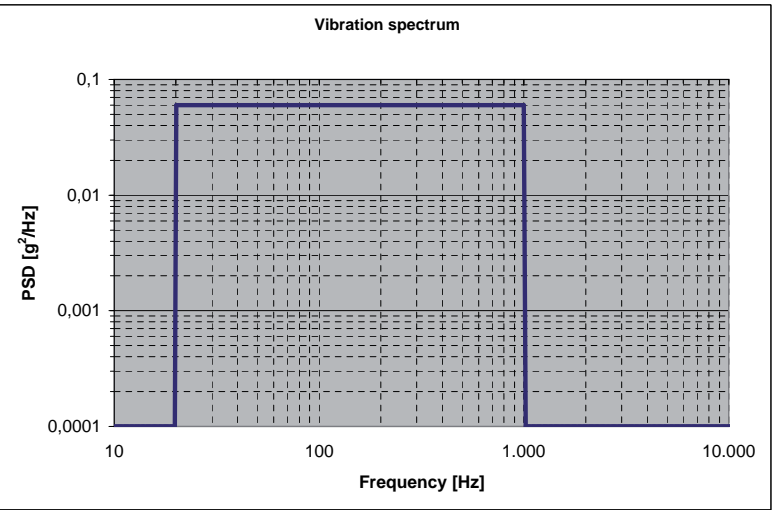
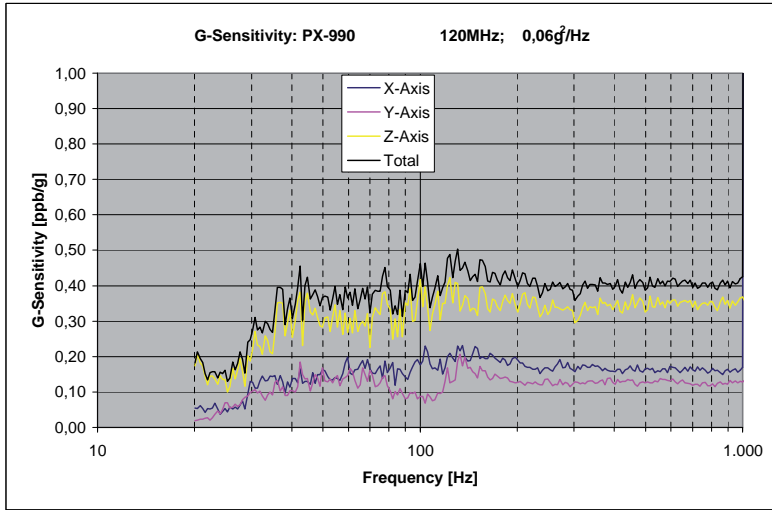

Calculation equation according to Vig-Tutorial

$$g\text{-sensitivity: } G = \frac{2 \cdot f_v}{A_{peak} \cdot f_0} \cdot 10^{\frac{L(f_v)}{20}}$$

$$\text{Peak g-level: } A_{peak} = \sqrt{PSD \cdot 2}$$

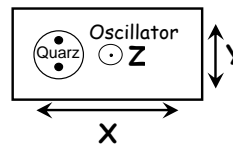

Comments:
Measured without shock absorbers



Typical Frequency Stability vs Temperature



Frequency and Pout vs. Temperature

Specification:	PX-990-0001	29.11.2010
Frequency:	120,000 MHz	
Osc.-No.:	SN1	

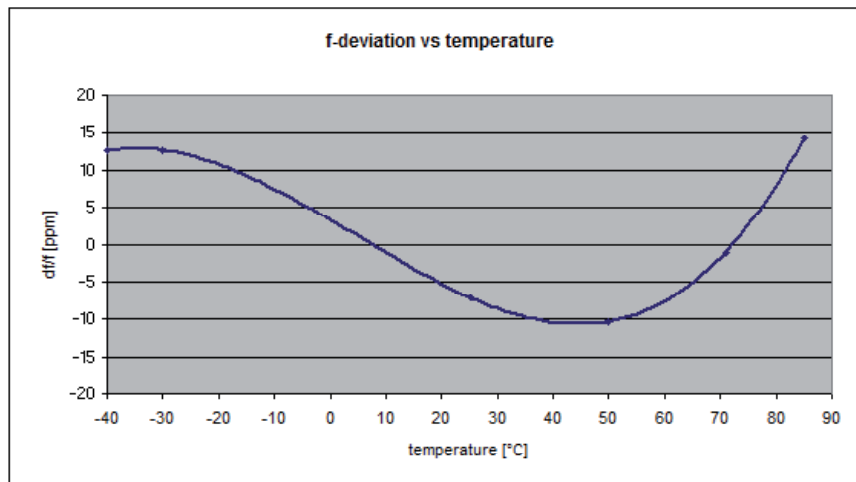

Typical Phase Noise @ 120 MHz with vibration

PX-990 without shock absorber
vibration spectrum DO-160 curve C

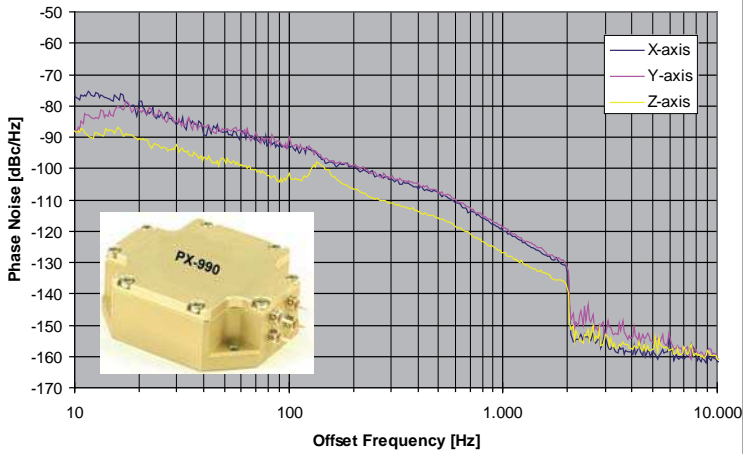

Vibration spectrum
RTCA / DO160-E; Curve C

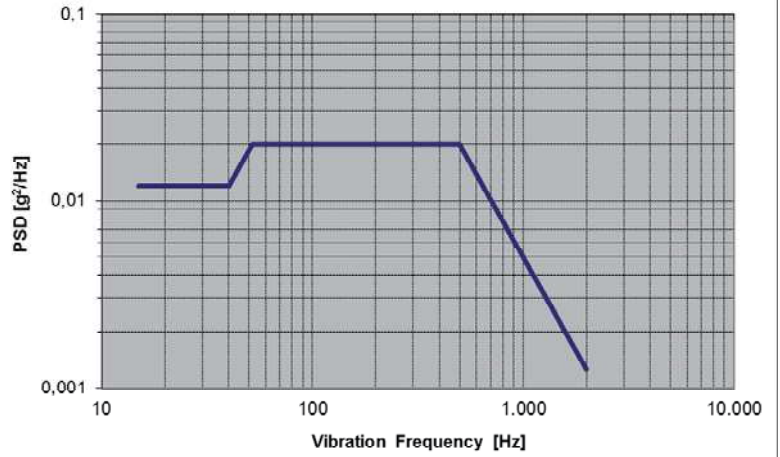

Typical Phase noise: PX-990
vibration spectrum DO-160 curve C

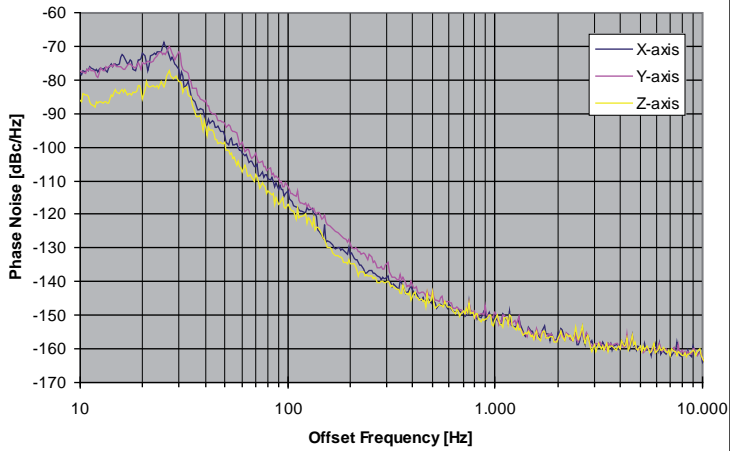

Typical Phase Noise: PX-990
vibration spectrum DO-160 curve C

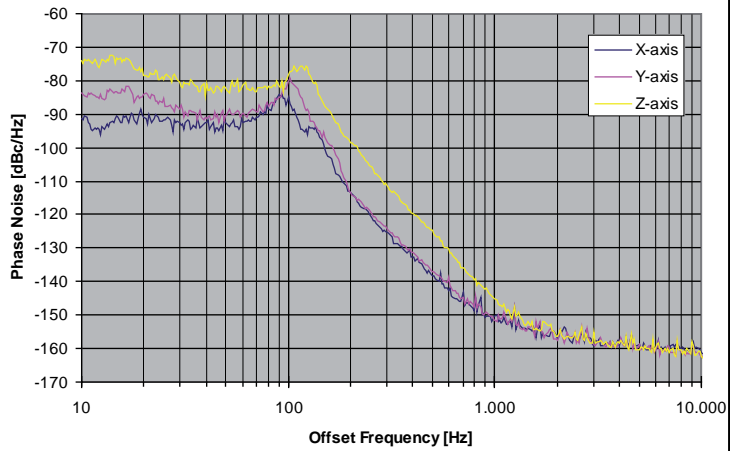

Ordering Information

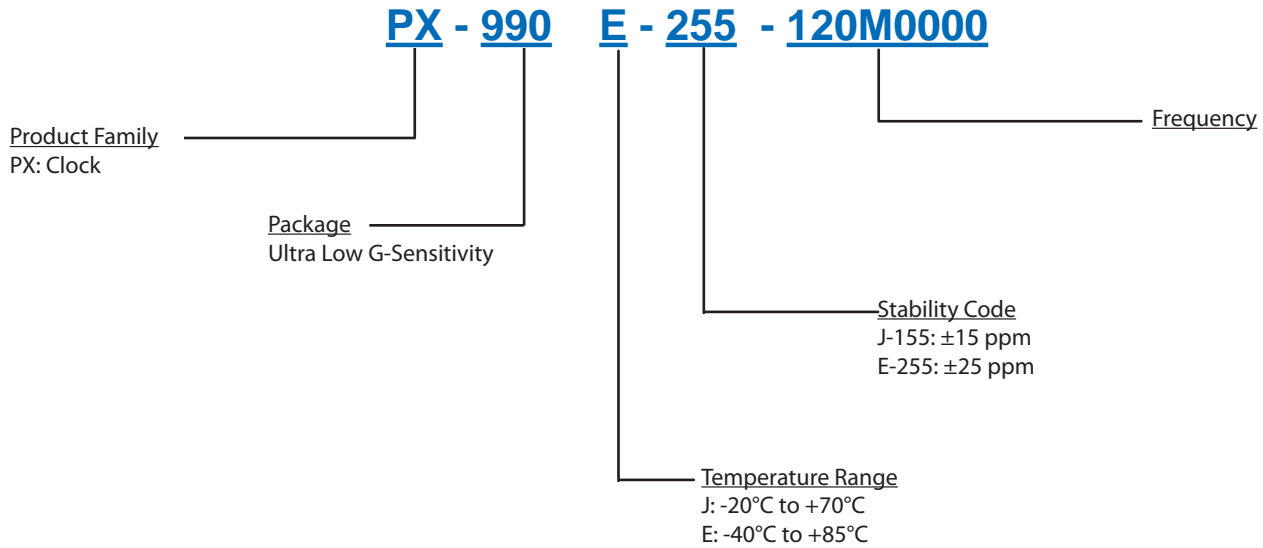

Notes:

1. Contact factory for improved stabilities or additional product options. Not all options and codes are available at all frequencies.
2. Phase noise degrades with increasing output frequency.
3. Contact factory for availability.

Unless other stated all values are valid after warm-up time and refer to typical conditions for supply voltage, frequency control voltage, load, temperature (25°C).

Subject to technical modification.

For Additional Information, Please Contact

USA:

Vectron International
267 Lowell Road
Hudson, NH 03051
Tel: 1.888.328.7661
Fax: 1.888.329.8328

Europe:

Vectron International
Landstrasse, D-74924
Neckarbischofsheim, Germany
Tel: +49 (0) 7268.801.100
Fax: +49 (0) 7268.801.282

Asia:

Vectron International
1589 Century Avenue, the 19th Floor
Chamtime International Financial Center
Shanghai, China
Tel: 86.21.6081.2888
Fax: 86.21.6163.3598

Disclaimer

Vectron International reserves the right to make changes to the product(s) and or information contained herein without notice. No liability is assumed as a result of their use or application. No rights under any patent accompany the sale of any such product(s) or information.

Rev: 03/2011