

Helping Customers Innovate, Improve & Grow



PX-508

Features

- Low G-Sensitivity
- Vibration hardened
- Tight Tolerances
- Low Phase Noise

Applications

- Vibration Environment
- Airborne and Military Equipment
- Portable Equipment
- Tactical Weapons

Performance Specifications²

Frequency Stabilities ¹ (Frequency Range - 10 to 120 MHz)						
Parameter	Min	Typical	Max	Units	Condition	Options ⁴
vs. operating temperature range (referenced to +25°C)	-15.0		+15.0	ppm	-20 to +70°C	
	-25.0		+25.0	ppm	-40 to +85°C	
	-40.0		+40.0	ppm	-55 to +105°C	
Initial tolerance	-10.0		+10.0	ppm	25°C	
vs. supply voltage change	-3.0		+3.0	ppm	V _s ±5% static	
vs. load change	-2.0		+2.0	ppm	Load ±10% static	
vs. aging / 1 year	-1.0		+1.0	ppm	after 30 days of operation	
vs. aging / 10 years	-5.0		+5.0	ppm	after 30 days of operation	

Performance Specifications²

Supply Voltage (Vs)						
Parameter	Min	Typical	Max	Units	Condition	
Supply voltage (standard) Current consumption	3.135	3.3	3.465 30	VDC mA	@LVCMOS	Option ¹
Supply voltage Current consumption	4.75	5.0	5.25 40	VDC mA	@HCMOS	
RF Output						
Signal [standard]	LVCMOS/HCMOS					
Load	13.5	15	16.5	pF		
Signal Level (Vol) LVCMOS			0.3	VDC	@ Vs=3.3V and 15pF Load	
Signal Level (Voh) LVCMOS	3.0			VDC	@ Vs=3.3V and 15pF Load	
Signal Level (Vol) HCMOS			0.5	VDC	@ Vs=5.0V and 15pF Load	
Signal Level (Voh) HCMOS	4.5				@ Vs=5.0V and 15pF Load	
Duty Cycle	40		60	%	@ (Voh-Vol)/2	
Rise and Fall time			5	ns	@15 pF 10 to 90 %	
Additional Parameters						
Phase Noise ³		-100		dBc/Hz	10 Hz	@ 77.76 MHz LVCMOS 3.3 V
		-128		dBc/Hz	100 Hz	
		-143		dBc/Hz	1 kHz	
		-153		dBc/Hz	10 kHz	
		-155		dBc/Hz	100 kHz	
Jitter		0.101		ps RMS	@ 12 kHz to 20 MHz	
Phase Noise ³		-90		dBc/Hz	10 Hz	@ 120 MHz LVCMOS 3.3 V
		-122		dBc/Hz	100 Hz	
		-142		dBc/Hz	1 kHz	
		-148		dBc/Hz	10 kHz	
		-155		dBc/Hz	100 kHz	
Jitter		0.062		ps RMS	@ 12 kHz to 20 MHz	
Weight			8.0	g		
Processing & Packing	Handling & Processing Note					
Additional Environmental Conditions						
Random Vibration	MIL-STD-202G; Method 214A; Condition II-J			1g2/Hz / 43.92 grms guaranteed (Qualification testing performed at MIL-STD-202G; Method 214A; Condition II-K, 1.5g2/Hz / 53.79 grms)		
Sine Vibration	MIL-STD-883; Method 2007			Test Condition B 50 g (Qualification testing performed at MIL-STD-883; Method 2007; Test Condition C 70 g)		
Shock	MIL-STD-883G; Method 2002.4; Condition D			5000 g / 0.3 ms higher values on request		
Solderability	JEDEC J-STD-002 100% RoHS 6 compliant					
Solvent Resistance	non-washable device					
Absolute Maximum Ratings						
supply voltage (Vs)			6.0	V		
Output Load			50	pF		
Operable Temperature Range	-55		+105	°C		
Storage Temperature Range	-55		+105	°C		

Typical G-Sensitivity @120 MHz; HCMOS

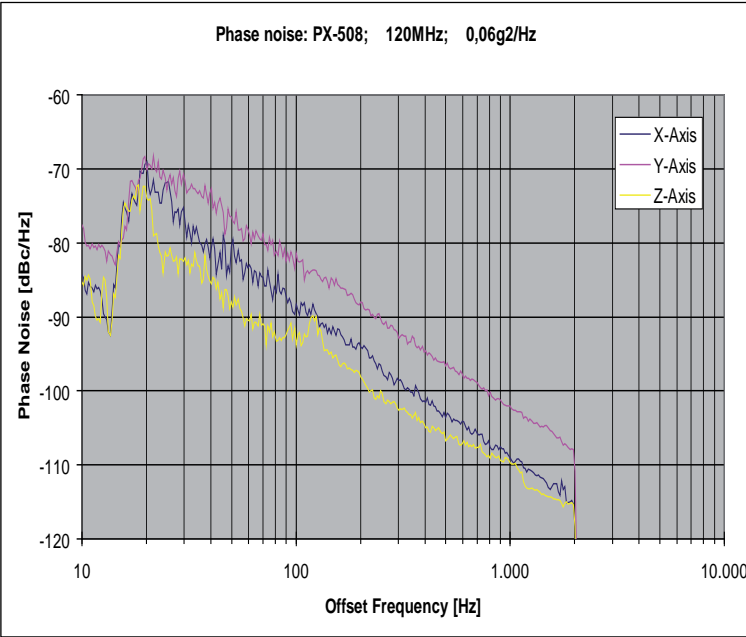
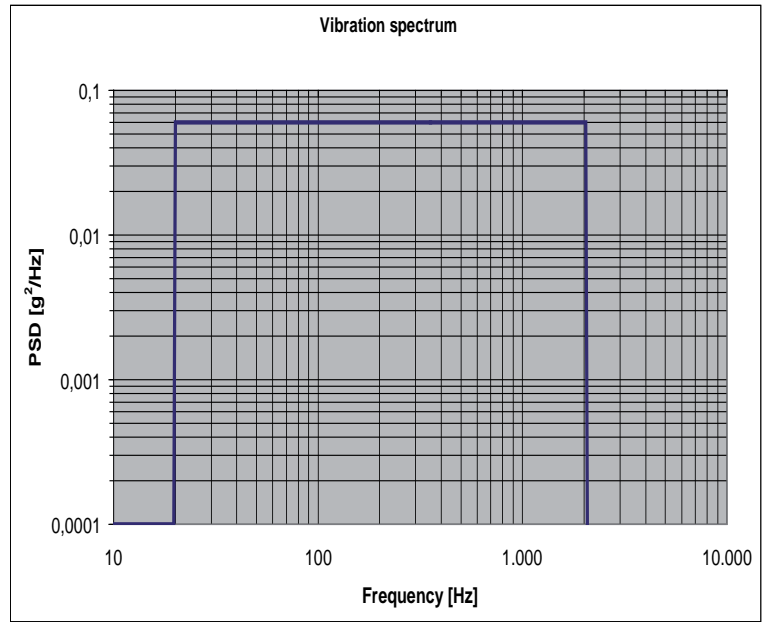
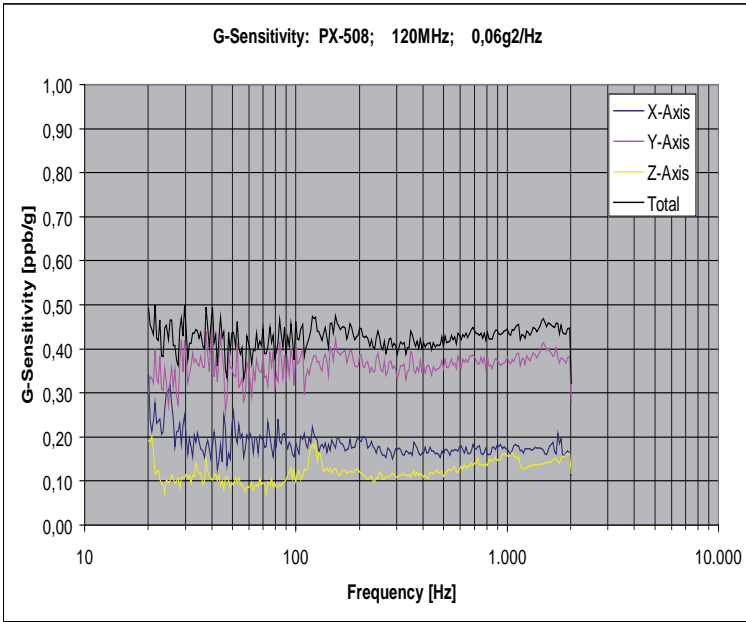

Calculation equation according to Vig-Tutorial

$$g\text{-sensitivity: } G = \frac{2 \cdot f_v}{A_{peak} \cdot f_0} \cdot 10^{\frac{L(f_v)}{20}}$$

$$\text{Peak g-level: } A_{peak} = \sqrt{PSD \cdot 2}$$

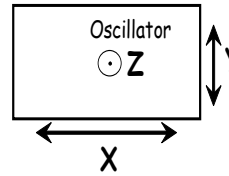

Typical Frequency Stability vs Temperature

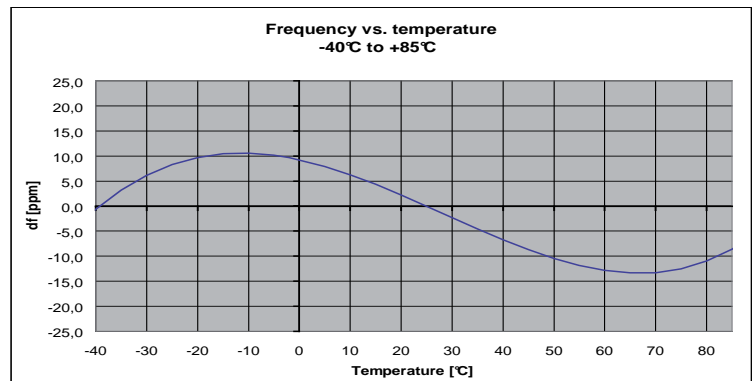
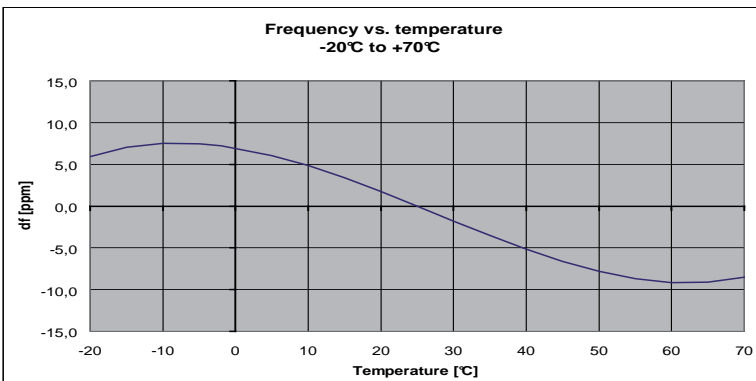

Standard Shipping Method (PX-508)

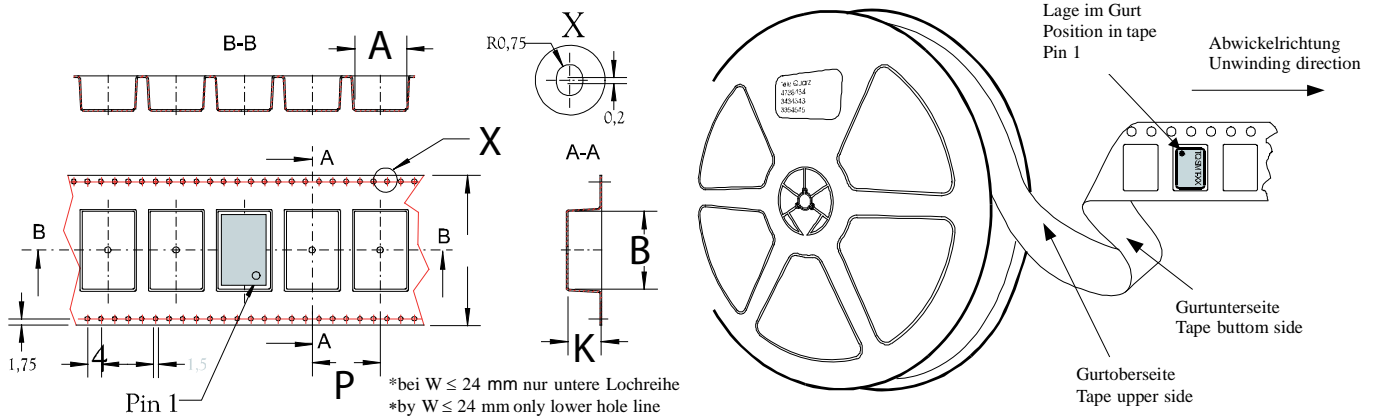

Enclosure Type	Tape Width W (mm)	Quantity per meter	Quantity per reel	Dimension P
G301	24	83,3	850	12

Recommended Reflow Profile

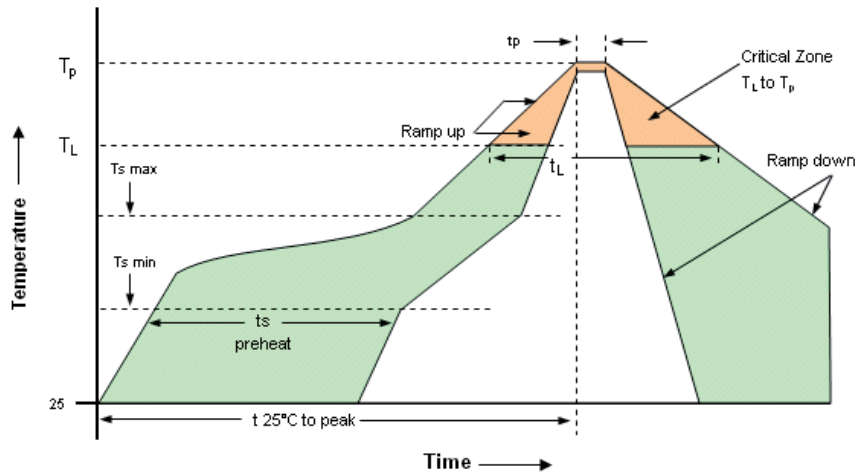

Profile Feature	Pb-Free Assembly/ Sn-Pb Assembly	Profile Feature	Pb-Free Assembly/ Sn-Pb Assembly
Average ramp-up rate (T_L to T_p)	3°C/second max.	Time 25°C to Peak Temperature	8 minutes max.
Preheat -Temperature Min T_{smin} -Temperature Min T_{smax} -Time (min to max) t_s	150°C 200°C 60-180 seconds	Time maintained above -Temperature (T_L) -Time (t_L)	217°C 60-150 seconds
T_{smax} to T_L -Ramp-up Rate	3°C/second max		
Time maintained above -Temperature (T_L) -Time (t_L)	217°C 60-150 seconds	Time within 5°C of actual Peak Temperature (t_p)	20-40 seconds
Peak Temperature (T_p)	max 260°C	Ramp-down Rate	6°C/ second max

Note: All temperatures refer to topside of the package, measured on the package body surface.

Ordering Information

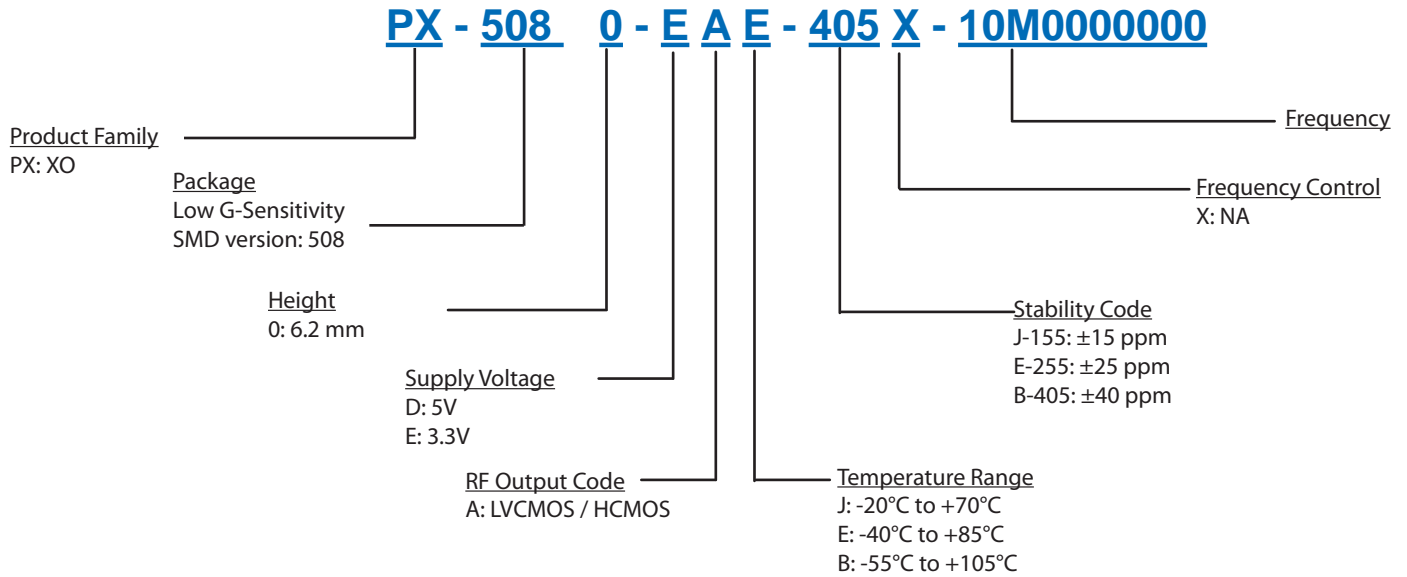

Notes:

1. Contact factory for improved stabilities or additional product options. Not all options and codes are available at all frequencies.
2. Unless other stated all values are valid after warm-up time and refer to typical conditions for supply voltage, load, temperature (25°C).
3. Phase noise degrades with increasing output frequency.
4. Contact factory for availability.

Subject to technical modification.

For Additional Information, Please Contact

USA:

Vectron International
267 Lowell Road
Hudson, NH 03051
Tel: 1.888.328.7661
Fax: 1.888.329.8328

Europe:

Vectron International
Landstrasse, D-74924
Neckarbischofsheim, Germany
Tel: +49 (0) 7268.801.100
Fax: +49 (0) 7268.801.282

Asia:

Vectron International
1589 Century Avenue, the 19th Floor
Chamtime International Financial Center
Shanghai, China
Tel: 86.21.6081.2888
Fax: 86.21.6163.3598

Disclaimer

Vectron International reserves the right to make changes to the product(s) and or information contained herein without notice. No liability is assumed as a result of their use or application. No rights under any patent accompany the sale of any such product(s) or information.

Rev: 06/2011