

Voltage Transducer LV 100-4200

$$V_{PN} = 4200 \text{ V}$$

For the electronic measurement of voltages : DC, AC, pulsed..., with a galvanic isolation between the primary circuit (high voltage) and the secondary circuit (electronic circuit).



Electrical data

V_{PN}	Primary nominal r.m.s. voltage	4200	V			
V_P	Primary voltage, measuring range	0 .. ± 6000	V			
I_{PN}	Primary nominal r.m.s. current	2.38	mA			
R_M	Measuring resistance	$R_{M \min}$	$R_{M \max}$			
				with $\pm 12 \text{ V}$	@ $\pm 4200 \text{ V}_{\max}$	0
			@ $\pm 6000 \text{ V}_{\max}$	0	82	Ω
		with $\pm 18 \text{ V}$	@ $\pm 4200 \text{ V}_{\max}$	0	254	Ω
	@ $\pm 6000 \text{ V}_{\max}$	0	161	Ω		
I_{SN}	Secondary nominal r.m.s. current	50	mA			
K_N	Conversion ratio	4200 V / 50 mA				
V_C	Supply voltage ($\pm 5 \%$)	$\pm 12 \dots 18$	V			
I_C	Current consumption	$25 + I_S$	mA			

Features

- Closed loop (compensated) voltage transducer using the Hall effect
- Insulated plastic case recognized according to UL 94-V0
- Primary resistor R_1 incorporated into the housing.

Advantages

- Excellent accuracy
- Very good linearity
- Low thermal drift
- High immunity to external interference.

Accuracy - Dynamic performance data

X_G	Overall Accuracy @ $V_{PN}, T_A = 25^\circ\text{C}$	± 1	%
ϵ_L	Linearity error	< 0.1	%
I_O	Offset current @ $I_P = 0, T_A = 25^\circ\text{C}$	Typ	Max
			± 0.3
I_{OT}	Thermal drift of I_O	± 0.5	± 1
t_r	Response time @ 90 % of $V_{P \max}$	100	μs

Applications

- Single or three phases inverter
- Propulsion and braking chopper
- Propulsion converter
- Auxiliary converter
- Battery charger.

General data

T_A	Ambient operating temperature	- 40 .. + 85	$^\circ\text{C}$
T_S	Ambient storage temperature	- 40 .. + 85	$^\circ\text{C}$
N	Turns ratio	42000 : 2000	
P	Total primary power loss	10	W
R_1	Primary resistance @ $T_A = 25^\circ\text{C}$	1.764	M Ω
R_S	Secondary coil resistance @ $T_A = 85^\circ\text{C}$	60	Ω
m	Mass	850	g
	Standards	EN 50155 : 2001	

Application domain

- Traction.

Voltage transducer LV 100-4200

Isolation characteristics

V_d	R.m.s. voltage for AC isolation test, 50/60 Hz, 1 mn	9.5 ¹⁾ 1 ²⁾	kV kV
V_e	R.m.s. voltage for partial discharge extinction @ 10pC	2 Min	kV
dCp	Creepage distance	74	mm
dCl	Clearance distance	38	mm
CTI	Comparative Tracking Index (Group III a)	175	

Notes : ¹⁾ Between primary and secondary + shield

²⁾ Between secondary and shield.

Safety



This transducer must be used in electric/electronic equipment with respect to applicable standards and safety requirements in accordance with the following manufacturer's operating instructions.



Caution, risk of electrical shock

When operating the transducer, certain parts of the module can carry hazardous voltage (eg. primary busbar, power supply).

Ignoring this warning can lead to injury and/or cause serious damage.

This transducer is a built-in device, whose conducting parts must be inaccessible after installation.

A protective housing or additional shield could be used.

Main supply must be able to be disconnected.

Dimensions LV 100-4200 (in mm. 1 mm = 0.0394 inch)

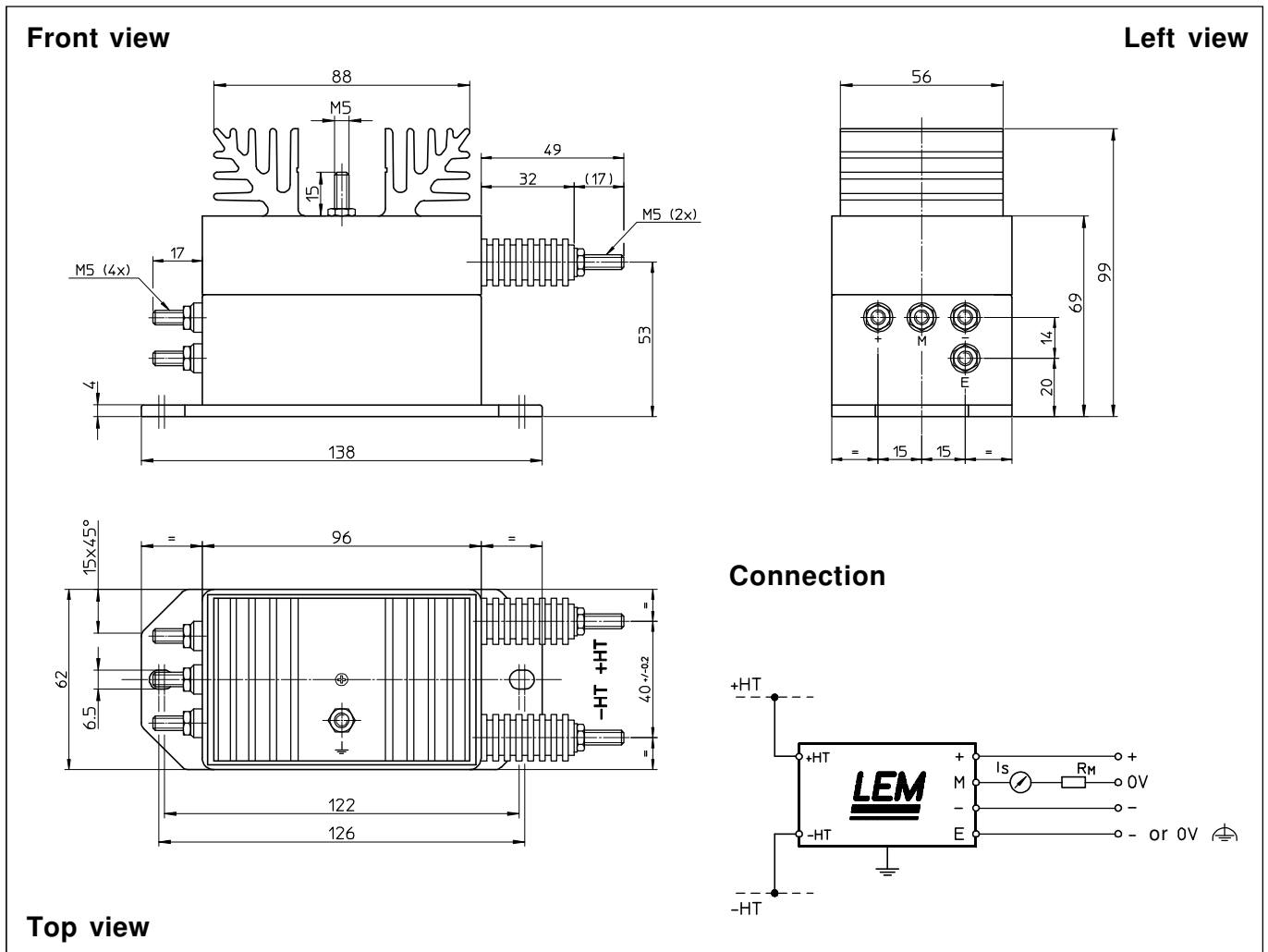

Mechanical characteristics

- | | |
|--------------------------------|------------------------------|
| • General tolerance | ± 0.3 mm |
| • Transducer fastening | 2 holes $\varnothing 6.5$ mm |
| • Connection of primary | 2 M5 threaded studs |
| • Connection of secondary | 4 M5 threaded studs |
| • Connection to the ground | M5 threaded stud |
| • Recommended fastening torque | 2.2 Nm or 1.62 Lb. -Ft. |

Remarks

- I_s is positive when V_p is applied on terminal +HT.
- The primary circuit of the transducer must be linked to the connections where the voltage has to be measured.
- This is a standard model. For different versions (supply voltages, turns ratios, unidirectional measurements...), please contact us.