

# Voltage Transducer LV 100-4000/SP6

For the electronic measurement of voltages: DC, AC, pulsed..., with galvanic isolation between the primary circuit and the secondary circuit.

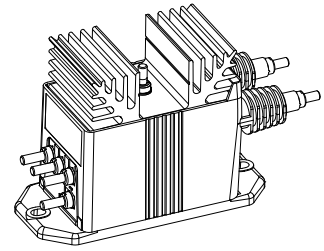

$$V_{PN} = 4000 \text{ V}$$



## Electrical data

$V_{PN}$	Primary nominal voltage rms	4000	V			
$V_{PM}$	Primary voltage, measuring range	0 .. $\pm 6000$	V			
$I_{PN}$	Primary nominal current rms	2.5	mA			
$R_M$	Measuring resistance	$R_{M \min}$	$R_{M \max}$			
				with $\pm 15 \text{ V}$	@ $\pm 4000 \text{ V}_{\max}$	0
			@ $\pm 6000 \text{ V}_{\max}$	0	120	$\Omega$
		with $\pm 24 \text{ V}$	@ $\pm 4000 \text{ V}_{\max}$	0	410	$\Omega$
	@ $\pm 6000 \text{ V}_{\max}$	110	250	$\Omega$		
$I_{SN}$	Secondary nominal current rms	50	mA			
$K_N$	Conversion ratio	4000 V / 50	mA			
$V_C$	Supply voltage ( $\pm 10 \%$ )	$\pm 15 \dots 24$	V			
$I_C$	Current consumption	$< 37$ (@ $\pm 24 \text{ V}$ ) + $I_S$	mA			

## Accuracy - Dynamic performance data

$X_G$	<sup>1)</sup> Overall accuracy @ $V_{PN}$ , $T_A = 25^\circ\text{C}$	$\pm 1$	%
$\epsilon_L$	Linearity error	$< 0.1$	%
$I_O$	Offset current @ $I_P = 0$ , $T_A = 25^\circ\text{C}$	Typ	$\pm 0.2$ mA
		Max	$\pm 0.6$ mA
$I_{OT}$	Temperature variation of $I_O$	- $25^\circ\text{C} \dots + 70^\circ\text{C}$	$\pm 0.4$ mA
		- $40^\circ\text{C} \dots + 85^\circ\text{C}$	$\pm 1.0$ mA
$t_r$	Response time <sup>2)</sup> to 90 % of $V_{PN}$ step	200	$\mu\text{s}$

## General data

$T_A$	Ambient operating temperature	- 40 .. + 85	$^\circ\text{C}$
$T_S$	Ambient storage temperature	- 50 .. + 90	$^\circ\text{C}$
$N$	Turns ratio	40000 : 2000	
$P$	Total primary power loss	10	W
$R_1$	Primary resistance	@ $T_A = 25^\circ\text{C}$	1.6 M $\Omega$
$R_S$	Secondary coil resistance	@ $T_A = 85^\circ\text{C}$	57 $\Omega$
$m$	Mass	790	g
	Standards	EN 50155: 1995	

Notes: <sup>1)</sup> The overall accuracy is  $\pm 6 \%$  at ambient temperature  $-50^\circ\text{C}$ , including a maximum offset drift 2.2 mA

<sup>2)</sup> With a  $di/dt$  of 100 A/ $\mu\text{s}$ .

## Features

- Closed loop (compensated) voltage transducer using the Hall effect
- Isolated plastic case recognized according to UL 94-V0
- Accessible electronic circuit
- Primary resistor  $R_1$  incorporated within the housing.

## Special features

- $V_C = \pm 15 \dots 24$  ( $\pm 10\%$ ) V
- $V_d = 12 \text{ kV}$  (to see note, page 2)
- $V_d = 2 \text{ kV}$  (to see note, page 2)
- $T_A = - 40^\circ\text{C} \dots + 85^\circ\text{C}$
- Connection to primary circuit by extra-long studs
- Connection primary and to secondary circuit on M5 threaded studs
- Shield between primary and secondary.

## Advantages

- Excellent accuracy
- Very good linearity
- Low thermal drift
- High immunity to external interference.

## Applications

- Single or three phase inverter
- Propulsion and braking chopper
- Propulsion converter
- Auxiliary converter
- Battery charger.

## Application Domain

- Traction.

## Voltage Transducer LV 100-4000/SP6

### Isolation characteristic

$V_d$	Rms voltage for AC isolation test, 50 Hz, 1 min	12 <sup>1)</sup>	kV
		2 <sup>2)</sup>	kV
$\hat{V}_w$	Impulse withstand voltage 1.2/50 $\mu$ s	34	kV
<b>dCp</b>	Creepage distance	Min 164.8	mm
<b>dCI</b>	Clearance	47.1	mm
<b>CTI</b>	Comparative Tracking Index (group I)	600	

Notes: <sup>1)</sup> Between primary and secondary + shield

<sup>2)</sup> Between secondary and shield.

### Safety



This transducer must be used in electric/electronic equipment with respect to applicable standards and safety requirements in accordance with the manufacturer's operating instructions.



Caution, risk of electrical shock

When operating the transducer, certain parts of the module can carry hazardous voltage (eg. primary busbar, power supply).

Ignoring this warning can lead to injury and/or cause serious damage.

This transducer is a build-in device, whose conducting parts must be inaccessible after installation.

A protective housing or additional shield could be used.

Main supply must be able to be disconnected.

## Dimensions LV 100-4000/SP6 (in mm)

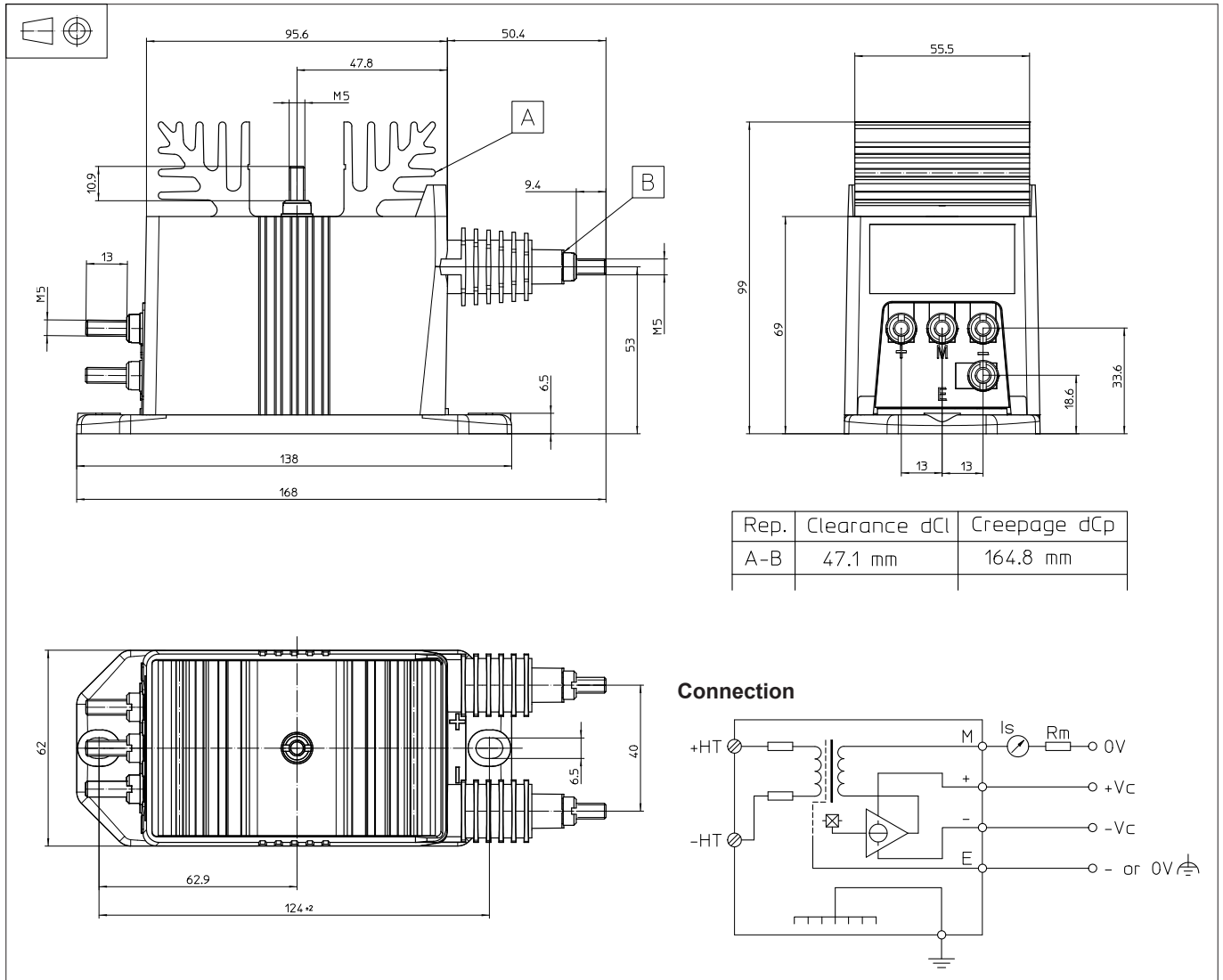

### Mechanical characteristics

- General tolerance  $\pm 0.3$  mm
- Transducer fastening
  - 2 holes  $\varnothing 6.5$  mm
  - 2 x M6 steel screws
  - Recommended fastening torque 5 Nm
- Connection of primary 2 M5 threaded studs
- Connection of secondary 4 M5 threaded studs
- Connection to the ground M5 threaded stud
- Recommended fastening torque 2.2 Nm

### Remarks

- $I_s$  is positive when  $I_p$  is applied on terminal + HT.
- Temperature of the primary conductor should not exceed  $100^\circ\text{C}$ .