

## Voltage Transducer LV 100-2000/SP17

For the electronic measurement of voltages: DC, AC, pulsed..., with galvanic isolation between the primary circuit (high voltage) and the secondary circuit (electronic circuit).

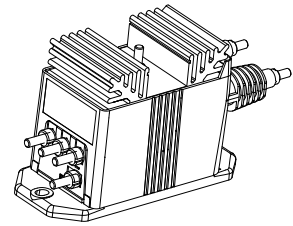

$V_{PN} = 2000 \text{ V}$



### Electrical data

|          |                                  |  |                               |                         |                               |          |
|----------|----------------------------------|--|-------------------------------|-------------------------|-------------------------------|----------|
| $V_{PN}$ | Primary nominal voltage rms      | 2000                                   | V                             |                         |                               |          |
| $V_{PM}$ | Primary voltage, measuring range | 0 .. $\pm 3000$                        | V                             |                         |                               |          |
| $I_{PN}$ | Primary nominal current rms      | 5                                      | mA                            |                         |                               |          |
| $R_M$    | Measuring resistance             | $R_{M \min}$                           | $R_{M \max}$                  |                         |                               |          |
|          |                                  |  |                               | with $\pm 15 \text{ V}$ | @ $\pm 1000 \text{ V}_{\max}$ | 0        |
|          |                                  |  | @ $\pm 2000 \text{ V}_{\max}$ | 0                       | 210                           | $\Omega$ |
|          |                                  |  | @ $\pm 3000 \text{ V}_{\max}$ | 0                       | 120                           | $\Omega$ |
|          |                                  | with $\pm 24 \text{ V}$                | @ $\pm 1000 \text{ V}_{\max}$ | 0                       | 880                           | $\Omega$ |
|          |                                  |  | @ $\pm 2000 \text{ V}_{\max}$ | 0                       | 410                           | $\Omega$ |
|          | @ $\pm 3000 \text{ V}_{\max}$    | 0                                      | 250                           | $\Omega$                |                               |          |
| $I_{SN}$ | Secondary nominal current rms    | 50                                     | mA                            |                         |                               |          |
| $K_N$    | Conversion ratio                 | 2000 V / 50 mA                         |                               |                         |                               |          |
| $V_C$    | Supply voltage ( $\pm 10\%$ )    | $\pm 15 \dots 24$                      | V                             |                         |                               |          |
| $I_C$    | Current consumption ( $\pm 1$ )  | $< 37$ (@ $\pm 24 \text{ V}$ ) + $I_S$ | mA                            |                         |                               |          |

### Accuracy - Dynamic performance data

|              |  |           |               |
|--------------|--|-----------|---------------|
| $X_G$        | Overall accuracy @ $V_{PN}, T_A = 25^\circ\text{C}$                          | $\pm 0.9$ | %             |
| $\epsilon_L$ | Linearity error  | $< 0.1$   | %             |
| $I_O$        | Offset current @ $I_P = 0, T_A = 25^\circ\text{C}$                           | Typ       | $\pm 0.2$ mA  |
|              |  | Max       | $\pm 0.6$ mA  |
| $I_{OT}$     | Temperature variation of $I_O$ - $25^\circ\text{C} \dots + 80^\circ\text{C}$ | $\pm 0.4$ | mA            |
| $t_r$        | Response time to 90 % of $V_{PN}$ step                                       | 60        | $\mu\text{s}$ |

### General data

|       |  |                |                  |
|-------|--|----------------|------------------|
| $T_A$ | Ambient operating temperature                        | - 25 .. + 80   | $^\circ\text{C}$ |
| $T_S$ | Ambient storage temperature                          | - 40 .. + 85   | $^\circ\text{C}$ |
| $N_P$ | Turns ratio  | 20000 : 2000   |                  |
| $P$   | Total primary power loss                             | 10             | W                |
| $R_1$ | Primary resistance @ $T_A = 25^\circ\text{C}$        | 400            | k $\Omega$       |
| $R_S$ | Secondary coil resistance @ $T_A = 80^\circ\text{C}$ | 56             | $\Omega$         |
| $m$   | Mass   | 790            | g                |
|       | Standards  | EN 50155: 1995 |                  |

### Features

- Closed loop (compensated) voltage transducer using the Hall effect
- Isolated plastic case recognized according to UL 94-V0
- Primary resistor  $R_1$  incorporated within the housing.

### Special features

- $V_C = \pm 15 \dots 24$  ( $\pm 10\%$ ) V
- $T_A = - 25^\circ\text{C} \dots + 80^\circ\text{C}$
- Shield around primary and secondary winding
- Connection to primary and secondary circuit on UNC 10-24 threaded studs.

### Advantages

- Excellent accuracy
- Very good linearity
- Low temperature drift
- Optimized response time
- Wide frequency bandwidth
- No insertion losses
- High immunity to external interference.

### Applications

- Single or three phase inverter
- Propulsion and braking chopper
- Propulsion converter
- Auxiliary converter
- Battery charger.

### Application Domain

- Traction.

## Voltage Transducer LV 100-2000/SP17

### Isolation characteristics

|            |   |                 |    |
|------------|---|-----------------|----|
| $V_d$      | Rms voltage for AC isolation test, 50 Hz, 1 min | 6 <sup>1)</sup> | kV |
|            |   | 1 <sup>2)</sup> | kV |
|            |   | Min             |    |
| <b>dCp</b> | Creepage distance                               | 164.8           | mm |
| <b>dCI</b> | Clearance distance                              | 47.1            | mm |
| <b>CTI</b> | Comparative Tracking Index (group I)            | 600             |    |

**Notes:** <sup>1)</sup> Between primary and secondary + shield + heat sink

<sup>2)</sup> Between secondary and shield.

### Safety



This transducer must be used in electric/electronic equipment with respect to applicable standards and safety requirements in accordance with the manufacturer's operating instructions.



Caution, risk of electrical shock

When operating the transducer, certain parts of the module can carry hazardous voltage (eg. primary busbar, power supply).

Ignoring this warning can lead to injury and/or cause serious damage.

This transducer is a build-in device, whose conducting parts must be inaccessible after installation.

A protective housing or additional shield could be used.

Main supply must be able to be disconnected.

## Dimensions LV 100-2000/SP17 (in mm)

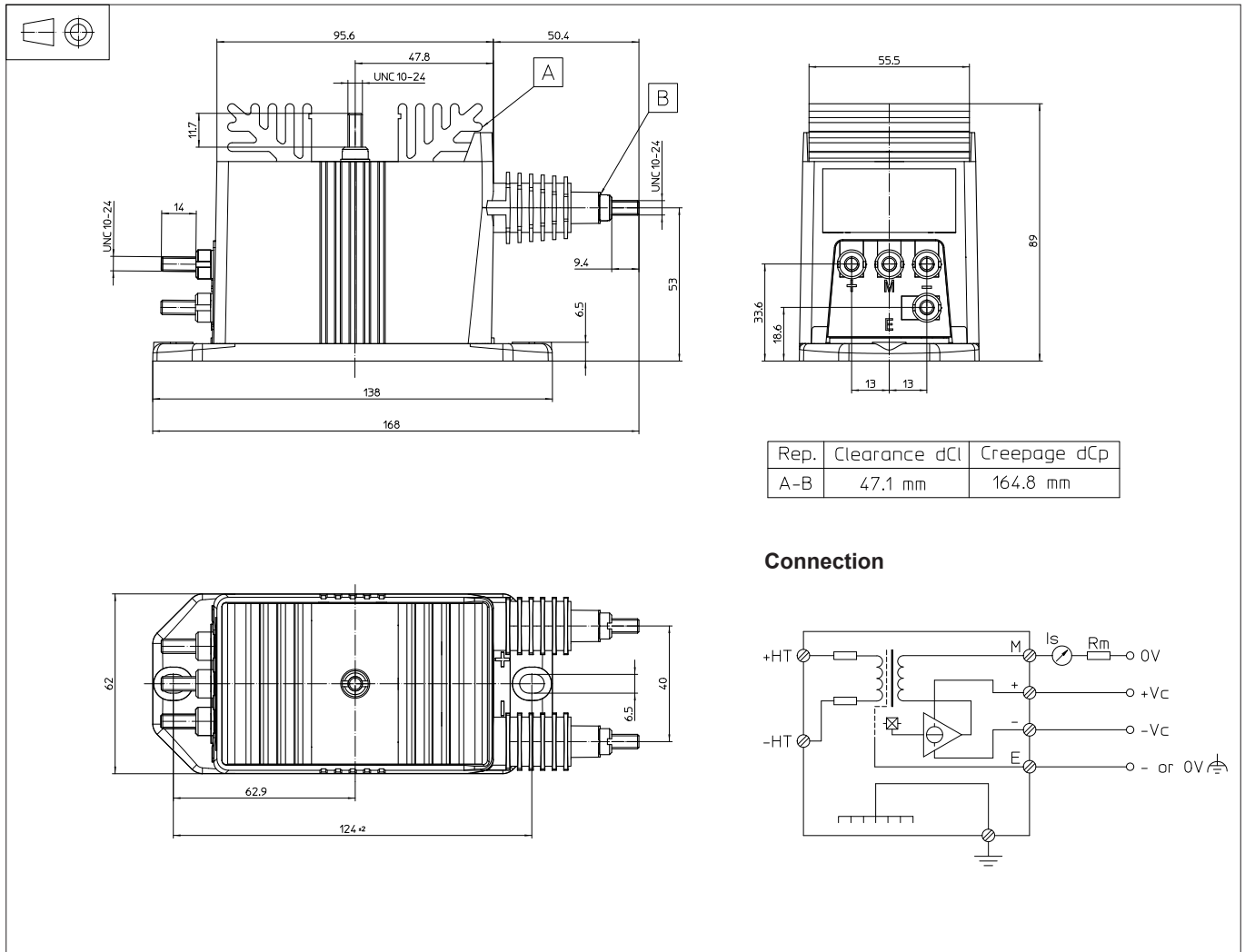

### Mechanical characteristics

- General tolerance  $\pm 0.3$  mm
- Transducer fastening 2 holes  $\varnothing 6.5$  mm,  
2 M6 or UNC 12-24 steel screws
- Recommended fastening torque 5 Nm
- Connection of primary UNC 10-24 threaded studs
- Connection of secondary UNC 10-24 threaded studs
- Connection to the ground UNC 10-24 threaded stud
- Recommended fastening torque 2.2 Nm

### Remarks

- $I_s$  is positive when  $V_p$  is applied on terminal +HT.
- The primary circuit of the transducer must be linked to the connections where the voltage has to be measured.