

# Fiber Optic GaAlAs LED in ST\* Receptacle Types OPF322A, OPF322B, OPF322C

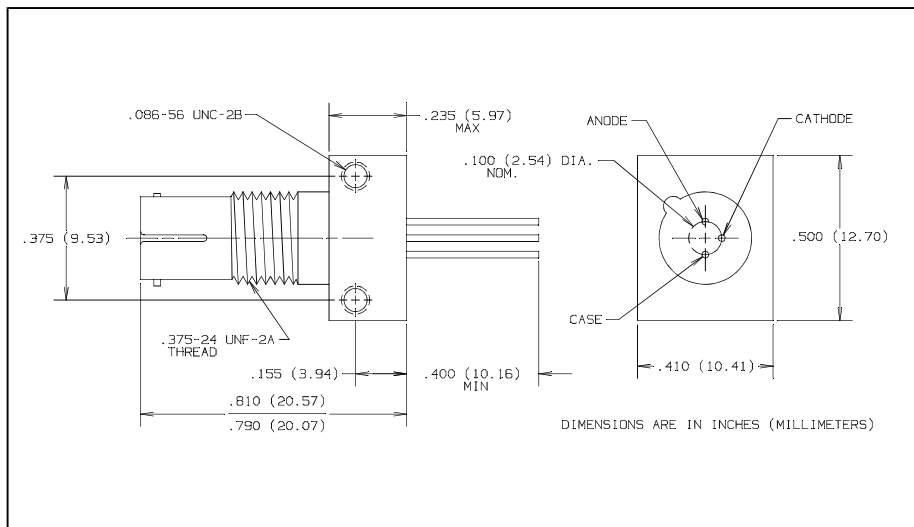
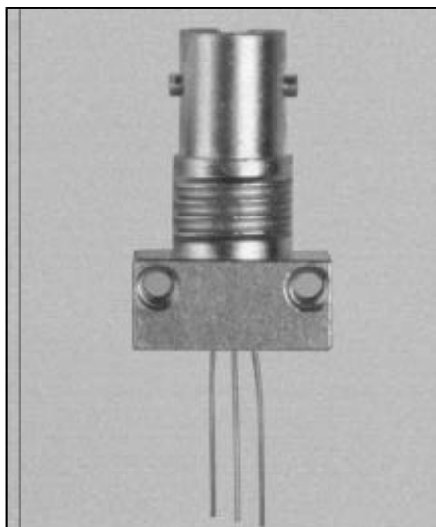

## Features

- Component pre-mounted and ready to use
- Pre-tested with fiber to assure performance
- Popular ST\* style receptacle

## Description

The OPF322 series LED consists of a hermetic LED, pre-mounted and aligned in an ST\* receptacle. This configuration is designed for PC board or panel mounting. Includes lock washer and jam nut, two 2-56 screws, and a dust cap.

The LED's are designed to interface with multimode optical fibers from 50/125 to 200/300 microns.

\*ST is a registered trademark of AT&T.

## Absolute Maximum Ratings (T<sub>A</sub> = 25° C unless otherwise noted)

Reverse Voltage	1.0 V
Continuous Forward Current	100 mA <sup>(4)</sup>
Storage Temperature Range	-55° C to +125° C
Operating Temperature Range	-40° C to +100° C
Lead Soldering Temperature [1/16 inch (1.6 mm) from case for 5 sec. with soldering iron]	240° C <sup>(1)</sup>

### Notes:

- (1) RMA flux is recommended. Duration can be extended to 10 sec. max when flow soldering.
- (2) Graded index fiber, 50 μm core, N.A. = 0.20.
- (3) To convert radiant power output to dBm, use the following expression dBm = 10 log (μW/1000).
- (4) Derate linearly @ 1.0 mA/° C above 25° C.
- (5) Prebias @ 5 mA current

## LED Burn-in

All LED's are subject to 100% burn-in testing. Test conditions are 96 hours at 100 mA continuous current in 25° C ambient.

## TYPICAL COUPLED POWER into OPTICAL FIBER

Typical Coupled Power					
I <sub>F</sub> = 100mA @ 25° C					
Fiber	Refractive Index	N.A.	OPF322C	OPF322B	OPF322A
50/125 μm	Graded	0.20	7.5 μW	12.5 μW	19 μW
62.5/125 μm	Graded	0.28	16 μW	22 μW	34 μW
100/140 μm	Graded	0.29	38 μW	62 μW	95 μW
200/300 μm*	Step	0.41	140 μW	235 μW	360 μW

\*PCS - Plastic Clad Silica

# Types OPF322A, OPF322B, OPF322C

Electrical Characteristics ( $T_A = 25^\circ\text{C}$  unless otherwise noted)

SYMBOL	PARAMETER		MIN	TYP	MAX	UNITS	TEST CONDITIONS
$P_O$	Radiant Power Output	OPF322C	5.0	7.5		$\mu\text{W}$	$I_F = 100\text{ mA}^{(2)}$
		OPF322B	10.0	12.5			
		OPF322A	15.0	19.0			
$V_F$	Forward Voltage			1.8	2.0	V	$I_F = 100\text{ mA}$
$\lambda_p$	Peak Output Wavelength		830	850	870	nm	$I_F = 50\text{ mA}$
B	Spectral Bandwidth Between Half Power Points			35		nm	$I_F = 50\text{ mA}$
$t_r$	Output Rise Time			6.0	8.0	ns	$I_F = 100\text{ mA}, 10\%-90\%^{(5)}$
$t_f$	Output Fall Time			6.0	10.0	ns	$I_F = 100\text{ mA}, 90\%-10\%^{(5)}$

## Typical Performance Curves

