

ERPQ Series Dual ProgramaCube® Dual Relay Output Module

3

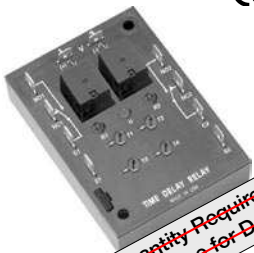

Minimum Order Quantity Required
Call Technical Assistance for Details



- Dual I/O Programmable Timer and Logic Module
- Factory Programmed to Your Requirements
- Can replace up to 6 Separate Timers
- Cost Effective for OEM Equipment
- 24 Standard Timing Functions to Choose From Special Time Ranges and Functions Available
- Dual Isolated SPDT Relay Outputs
- Dual Initiate Switches to Start Functions
- 4 Onboard, Fixed, or External Adjustments
- 12 to 230 V Input Voltages in 5 Ranges
- 3 LED Indicators, Green - Input On, Red-Relay Energized

Approvals:

Accessories

- External adjust potentiometer
P/Ns:
P1004-95 (fig A)
P1004-95-X (fig B)
- Female quick connect
P/N:
P1015-64 (AWG 14/16)
- Quick connect to screw adaptor
P/N: **P1015-18**
- Versa-knob
P/N: **P0700-7**

See accessory pages for specifications.

Description

The ERPQ Series is a factory programmed dual switch input, dual relay output, timer and counter logic module. The ERPQ is designed to offer custom controller capabilities without the long development time associated with a dedicated control board. By using this ProgramaCube® approach, new user functions and time ranges, can be created quickly and inserted into CE marked, UL recognized, and CSA certified modules. This approach eliminates three of the most time consuming steps in the custom product development process. Upon approval of your user function, manufacturing of production quantities can be scheduled without lengthy delays. Unlike PLC's and other user programmable controls, no programming experience is required. You outline the required function by constructing a time diagram and a description of the operation; including which time delays are fixed and which are onboard or externally adjustable. Our technical support team will take it from there. A customer specified function can include predetermined count targets and up to 4 adjustable time delays. It can include any combination of the typical timing and counting functions available in traditional timers and predetermined counters. The input switches can be used to initiate time delays or count sequences, restart the function, or monitor alarm contacts. The ERPQ programmable logic modules are encapsulated to protect the electronic circuitry against shock, vibration and humidity. They are backed by our exclusive 10 year warranty.

Connection

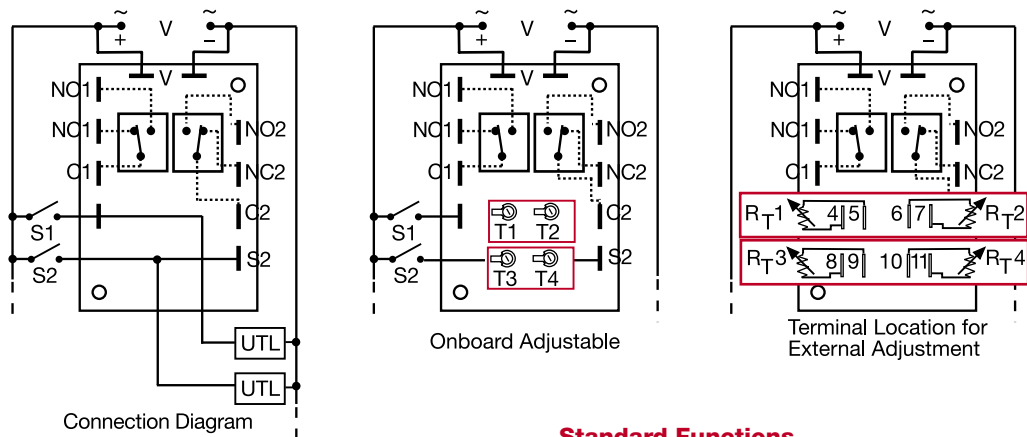

UTL = Optional Untimed Load
S1, S2 = Initiate Switches
RT is used when External Adjustment is ordered
4, 5; 6, 7; 8, 9; 10; 11 are included when external adjust is specified. Dashed lines are internal connections.

Standard Time Delay Ranges

| | |
|------------------|---------------------------|
| 1 - 0.1... 10 s | (min. custom range 1 s) |
| 2 - 1... 100 s | (min. custom range 10 s) |
| 3 - 10...1000 s | (min. custom range 100 s) |
| 4 - 0.1... 10 m | (min. custom range 1 m) |
| 5 - 1... 100 m | (min. custom range 10 m) |
| 6 - 10... 1000 m | (min. custom range 100 m) |
| 7 - 0.1... 10 h | (min. custom range 1 h) |
| 8 - 1... 100 h | (min. custom range 10 h) |
| 9 - 10...1000 h | (min. custom range 100 h) |

Standard Functions

- Alternating Relay
- Delay on Make
- Delay on Make (Coarse/Fine Adjust)
- Accumulative Delay on Make
- Delay on Break
- Delay on Break (Coarse/Fine Adjust)
- Flip - Flop (Leading Edge Triggered)
- Inverted Delay on Break
- Delay on Break/Recycle (ON First, Equal)
- Interval
- Interval (Coarse/Fine Adjust)
- Recycle (ON First, Equal Times)
- Recycle (ON First, Equal Times)(Coarse/Fine Adjust)
- Recycle (OFF First, Equal Times)
- Recycle (OFF First, Equal Times)(Coarse/Fine Adjust)
- Recycle (Both Times Adj. ON First)
- Recycle (Both Times Adj. OFF First)
- Single Shot
- Single Shot (Coarse/Fine Adjust)
- Trailing Edge Single Shot
- Trailing Edge Single Shot (Coarse/Fine Adjust)
- Inverted Single Shot
- Retriggerable Single Shot
- Single Shot/Recycle (ON First, Equal)

Ordering Table

| ERPQ Series | X | C - | XXXX |
|-------------|--------------------|-----|------------------------|
| | Input | | Function Number |
| | - 1 - 12 V DC | | 4 Digit Number |
| | - 2 - 24 V AC/DC | | Assigned by the |
| | - 4 - 120 V AC | | Technical Support Team |
| | - 5 - 110 V DC | | |
| | - 9 - 120/230 V AC | | |

Example P/N: **ERPQ4C-4392, ERPQ1C-4350, ERPQ9C-4397**

ERPQ Series Dual ProgramaCube® Dual Relay Output Module

Technical Data

| | |
|---|---|
| Time Delay | |
| Type | Microcontroller circuitry |
| Range | 0.1 s ... 1000 h in 9 adjustable ranges or fixed |
| Repeat Accuracy | +/-1% or 20 ms, whichever is greater |
| Tolerance (Factory Calibration) | ≤ +/-2% or 20 ms, whichever is greater |
| Reset Time | ≤ 250 ms |
| Initiate Time | ≅ 40 ms |
| Time Delay vs Temperature & Input Voltage | ≤ +/-2% |
| Input | |
| Voltage | 12, 24, or 110 V DC; 24, 120, or 120/230 V AC |
| Tolerance | 12 V DC & 24 V DC/AC -15%... +20% 110 V DC; 120/230 V AC -20%...+10% |
| AC Line Frequency | 50 ... 60 Hz |
| DC Ripple | ≤ 10% |
| Power Consumption | 12 VDC - ≤ 1.5 W, 24 V AC/DC - ≤ 1.5 VA/W 110 V DC - ≤ 2.5 W, 120/230 V AC - ≤ 2.5 VA |
| Output | |
| Type | Two SPDT isolated relays |
| Form | Single pole double throw, SPDT |
| Rating (at 40°C) [each relay] | 10 A res. at 125 V AC; 5 A res. at 230 V AC 5 A resistive at 28 V DC, ¼ hp at 125 V AC |
| Maximum Switching Voltage | 250 V AC |
| Life | Mechanical – 1 x 10 ⁶ operations Electrical – 1 x 10 ⁵ |
| Protection | |
| Circuitry | Encapsulated |
| Isolation Voltage | ≥ 1500 V RMS input to output |
| Insulation Resistance | ≥ 100 MΩ |
| Polarity | DC units are reverse polarity protected |
| Mechanical | |
| Mounting | Surface mount with two #6 (M3.5 x 0.6) screws |
| Package | 2.5 x 3.5 x 1.22 in. (63.5 x 88.9 x 31 mm) |
| Termination | 0.25 in. (6.35 mm) male quick connect terminals |
| Environmental | |
| Operating/Storage Temperature | -40°C ... +60°C / -40°C ... +85°C |
| Humidity | 95% relative, non-condensing |
| Weight | 6.4 oz (181 g) |

External Resistance vs Time Delay

In Secs., Mins., or Hours

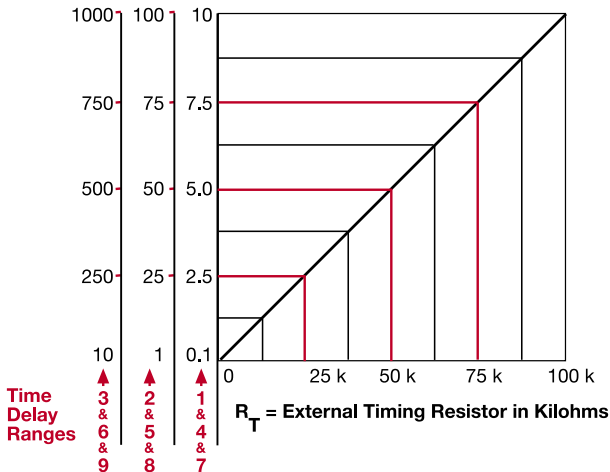

This chart applies to externally adjustable part numbers. The time delay is adjustable over the time delay range selected by varying the resistance across the R_T terminals; as the resistance increases the time delay increases. When selecting an external R_T , add the tolerances of the timer and the R_T for the full time range adjustment.
Examples: 1 to 50 S adjustable time delay, select time delay range 2 and a 50 K ohm R_T . For 1 to 100 S use a 100 K ohm R_T .

Mechanical View

