

Voltage Transducer AV 100-2000/SP1

For the electronic measurement of voltages: DC, AC, pulsed..., with galvanic isolation between the primary circuit (high voltage) and the secondary circuit (electronic circuit).

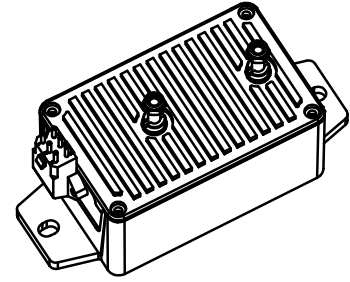

$V_{PN} = 2000 \text{ V}$



Electrical data

V_{PN}	Primary nominal voltage rms	2000	V
V_{PM}	Primary voltage, measuring range	± 3000 ¹⁾	V
\hat{V}_P	Peak primary voltage	4500 (1s/h)	V_{DC}
R_P	Primary resistance	17.8M	Ω
R_M	Measuring resistance	$R_{M \min}$ $R_{M \max}$	Ω
	@ $V_C = 11.4 \text{ V}$	0 47	Ω
	@ $V_C = 22.8 \text{ V}$	0 184	Ω
I_{SN}	Secondary nominal current rms	50	mA
V_C	Supply voltage ($\pm 5 \%$)	DC $\pm 12 \dots 24$	V
I_C	Current consumption	$50 + I_S$	mA

Accuracy - Dynamic performance data

X_G	Overall Accuracy @ V_{PN} , $T_A = 25^\circ\text{C}$	± 0.7	%
X_G	Overall Accuracy @ V_{PN} , $T_A = -25 \dots +70^\circ\text{C}$	± 1.5	%
X_G	Overall Accuracy @ V_{PN} , $T_A = -40 \dots +85^\circ\text{C}$	± 1.7	%
\mathcal{E}_L	Linearity error @ $T_A = 25^\circ\text{C}$	< 0.1	%
I_O	Offset current @ $V_P = 0$, $T_A = 25^\circ\text{C}$	± 0.15	mA
t_r	Response time	< 30	μs
BW	Frequency bandwidth (-3 dB)	DC .. 11	kHz

General data

T_A	Ambient operating temperature	-40 .. +85	$^\circ\text{C}$
T_S	Ambient storage temperature	-50 .. +90	$^\circ\text{C}$
m	Mass	380	g
	Standards	EN 50155 (2001) EN 50124-1 (2001) NFF16101/2 (1988)	

Features

- Insulated plastic case recognized according to UL 94-V0
- Included primary resistor.

Special feature

- Secondary connections on Burndy connector.

Advantages

- Low power
- Excellent accuracy
- Very good linearity
- Low thermal drift
- Low response time
- High bandwidth
- High immunity to external interference
- Low disturbance in common mode.

Applications

- Single or three phases inverter
- Propulsion and braking chopper
- Propulsion converter
- Auxiliary converter
- Battery charger

Application Domain

- Traction.

Note : ¹⁾ 500 ms every 60 minutes.

Voltage Transducer AV 100-2000/SP1

Isolation characteristics

V_d	Rms voltage for AC isolation test, 50 Hz, 1 min Max Common mode voltage and	6.5	kV
		$U_{HT+} + U_{HT-} \leq 4.2 \text{ kVDC}$	
		$ U_{HT+} - U_{HT-} \leq V_{PM}$	
V_e	Partial discharge extinction voltage rms @ 10 pc	2.2	kV
		min	
dCp	Creepage distance	57	mm
dCI	Clearance distance	32	mm
CTI	Comparative tracking index (Group I)	600	

Safety



This transducer must be used in electric/electronic equipment with respect to applicable standards and safety requirements in accordance with the manufacturer's operating instructions.



Caution, risk of electrical shock

When operating the transducer, certain parts of the module can carry hazardous voltage (eg. primary busbar, power supply).

Ignoring this warning can lead to injury and/or cause serious damage.

This transducer is a build-in device, whose conducting parts must be inaccessible after installation.

A protective housing or additional shield could be used.

Main supply must be able to be disconnected.

Dimensions AV 100-2000/SP1 (in mm)

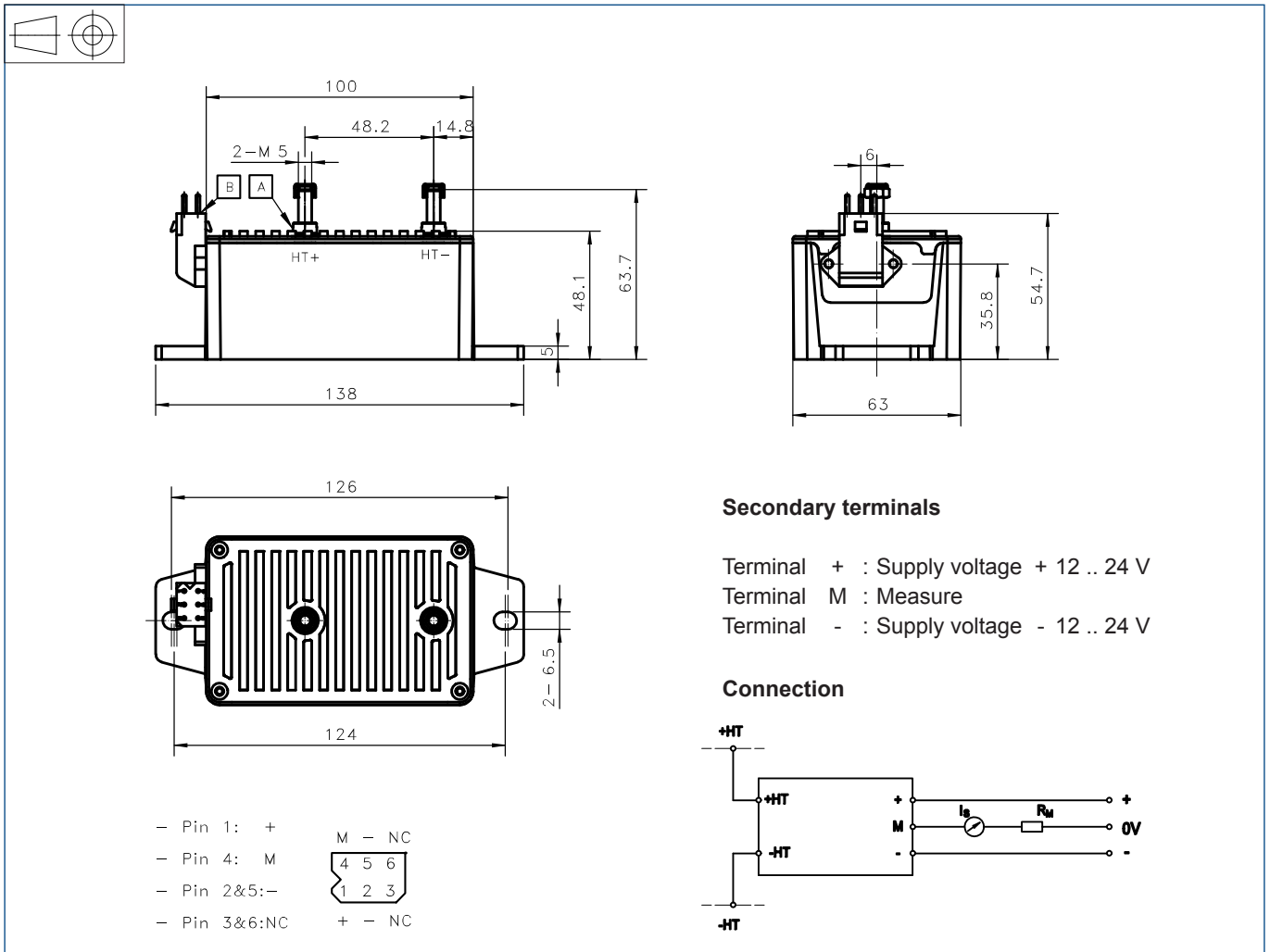

Mechanical characteristics

- General tolerance ± 1 mm
- Transducer fastening 2 holes $\varnothing 6.5$ mm
2 M6 screws
Recommended fastening torque 4 Nm
- Fastening & connection of primary 2 x M5 threaded studs
Recommended fastening torque 2.2 Nm
- Connection of secondary SMS6GE6 Burndy connector
Output connections must be made with screened cables

Remarks

- I_s is positive when V_p is applied on terminal +HT.