

# Current Transducer ITL 4000-S

$I_{PN} = 4000 \text{ A}$

For the electronic measurement of current: DC, AC, pulsed..., with galvanic isolation between the primary (high power) and the secondary circuit (electronic circuit).

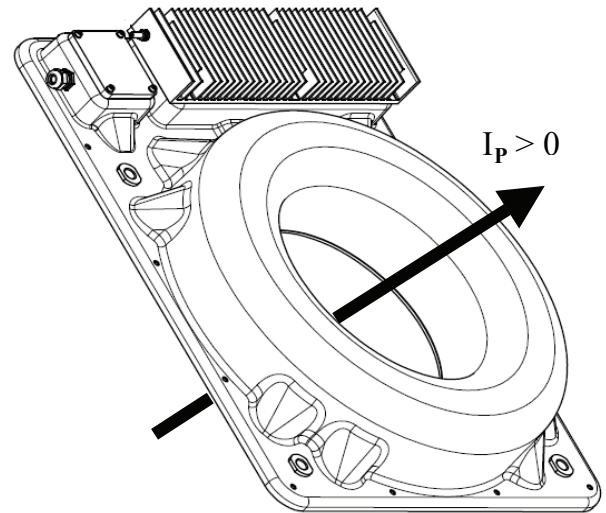

## Features

- Closed loop (compensated) current transducer
- Current output
- Bipolar supply voltage
- High accuracy.

## Advantages

- Integrated design
- Low cost
- Large aperture.

## Applications

- HVDC
- Medium voltage PFC and active filters
- Small DC component detection in large AC currents (transformer protection).

## Standards

- EN 50178
- EN 61010-1
- UL 94-V0
- RoHS.

## Application Domain

- Industrial.

## Absolute maximum ratings

Parameter	Symbol	Unit	Value
Maximum supply voltage (non-operating)	$V_C$	V	±30
Primary conductor temperature		°C	70

Stresses above these ratings may cause permanent damage. Exposure to absolute maximum ratings for extended periods may degrade reliability.

## Isolation characteristics

### Isolation between primary and secondary + shield

Parameter	Symbol	Unit	Value	Comment
Rated isolation voltage	$V_b$	kV	1.5	
RMS voltage for AC isolation test 50/60Hz/1 min	$V_d$	kV	6.4	100 % tested
Impulse withstand voltage 1.2/50 $\mu$ s	$\hat{V}_w$	kV	16.5	
Clearance distance (pri. - sec.)	<b>dCl</b>	mm	>130	
Creepage distance (pri. - sec.)	<b>dCp</b>	mm	>200	
Overvoltage category		-	CAT III	Reinforced isolation according to EN 61010
Pollution degree		-	PD2	
Partial discharge extinction voltage @ 10 pC (rms)	$V_e$	kV	2.65	
Comparative tracking index	<b>CTI</b>	V	>600	

### Isolation between shield and secondary

Parameter	Symbol	Unit	Value	Comment
Rated isolation voltage	$V_b$	V	150	
RMS voltage for AC isolation test 50/60Hz/1 min	$V_d$	kV	2.7	100 % tested
Impulse withstand voltage 1.2/50 $\mu$ s	$\hat{V}_w$	kV	5	
Clearance distance (shield - sec.)	<b>dCl</b>	mm	>4	
Creepage distance (shield - sec.)	<b>dCp</b>	mm	>5.5	
Overvoltage category		-	CAT III	Reinforced isolation according to EN 61010
Pollution degree		-	PD2	

## Environmental and mechanical characteristics

Parameter	Symbol	Unit	Min	Typ	Max	Comment
Ambient operating temperature	$T_A$	°C	-40		70	
Ambient storage temperature	$T_S$	°C	-40		70	
Aperture diameter		mm	265	268		
Dimensions (W x H x D)		mm		500 x 643 x 118		
Mass		kg		40		

**Electrical data**

 At  $T_A = 25\text{ °C}$ ,  $V_C = \pm 24\text{ V}$ , unless otherwise noted.

Parameter	Symbol	Unit	Min	Typ	Max	Comment
Primary nominal current rms	$I_{PN}$	A		4000		
Primary current, measuring range	$I_{PM}$	A			12000	
Output current	$I_S$	A		1.6	4.8	
Bipolar supply voltage	$V_C$	V	$\pm 22.8$	$\pm 24$	$\pm 25.2$	
Measuring resistance	$R_M$	$\Omega$	0		1	@ $I_{PM}, T_{Cu} = 100\text{ °C}$ , cable resistance included (see fig. 1 and 2)
Current consumption	$I_C$	A		$0.22 + I_S$	$0.35 + I_S$	
Offset current	$I_{OE}$	mA	-0.1		0.1	
Maximum offset change after $5 \times I_{PN}$	$I_{OM}$	mA	-0.2		0.2	
Offset drift of $I_O$	$I_{OT}$	mA	-0.1		0.1	-40 °C .. 70 °C
Number of secondary turns	$N_S$			2500		
Sensitivity error	$\epsilon_G$	%	-0.04		0.04	
Linearity error	$\epsilon_L$	% of $I_{PN}$	-0.01		0.01	
Output current noise, 0.1 Hz .. 10 kHz	$I_{no}$	A		0.5		Input referred, rms
Reaction time @ 10 % of $I_{PN}$	$t_{ra}$	$\mu s$			2	@ $I_{PN}, 100\text{ A}/\mu s$
Response time @ 90 % of $I_{PN}$	$t_r$	$\mu s$			10	@ $I_{PN}, 100\text{ A}/\mu s$
Frequency bandwidth ( $\pm 1\text{ dB}$ )	<b>BW</b>	kHz		50		@ $I_P$ (rms) = 40 A, $R_M = 50\ \Omega$
Overall accuracy	$X_G$	% of $I_{PN}$	-0.06		0.06	
Overall accuracy	$X_G$	% of $I_{PN}$	-0.08		0.08	In temperature range -40 °C .. 70 °C
Total error from $I_{PNDC} = -10\text{ A}$ up to +10 A		A	-1		1	$T_A = -25\text{ °C} \dots 50\text{ °C}$ $I_{PNAC} = I_{PN}, \text{max. } 100\text{ Hz}$
Output deviation under test according to IEC 61000-4-3		% of $I_{PN}$			3	Radiated immunity to RF fields, 80 .. 1000 MHz
Output deviation under test according to IEC 61000-4-6		% of $I_{PN}$			3	Immunity to conducted disturbances of RF fields 0.15 .. 80 MHz

Maximum measuring resistance (included cable) versus measuring range

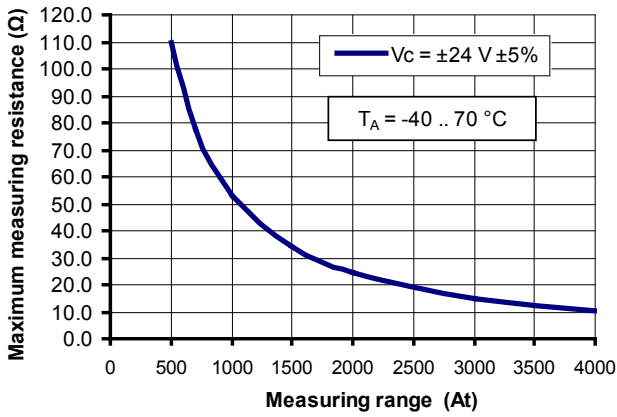

Figure 1:  $R_M$  for ranges 0 .. 4000 A

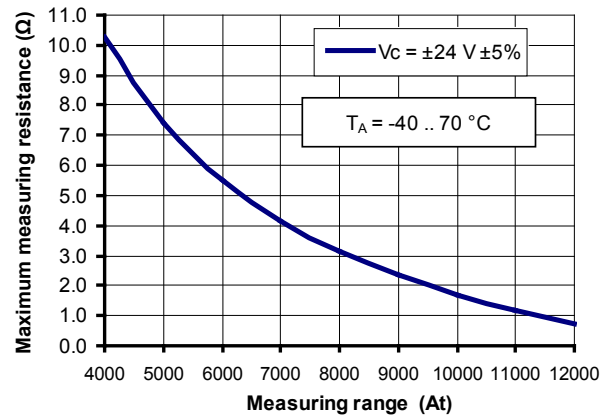

Figure 2:  $R_M$  for ranges 4000 .. 12000 A

Typical Bandwidth @  $I_p = 40$  A

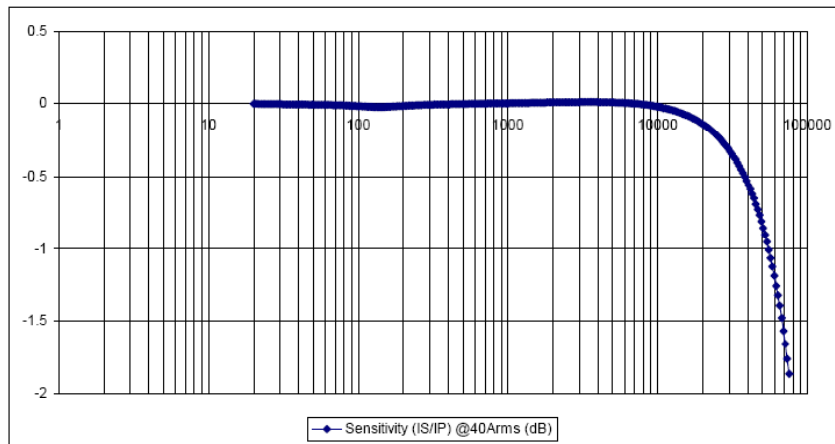

Figure 3: Bandwidth

Typical step response

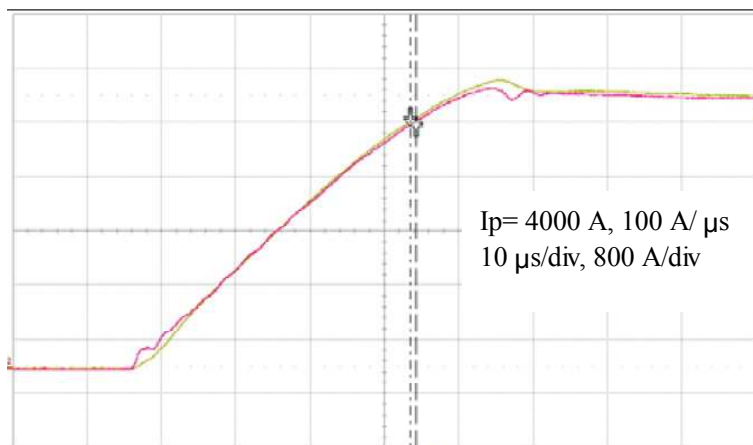

Figure 4: Step response  $di/dt$

## Installation

### Mounting

The ITL 4000-S transducer should be mounted on a flat surface, its flat side against the surface. The fins of the heatsink should be oriented vertically for a better heat dissipation

The transducer should be fixed with 4 screws complying with the inner diameter of the 4 bushings.

### Connection

Remove the 4 screws that hold the small cover near the heatsink (see fig. 9). The tightening torque for these 4 screws is 1.3 Nm. The torque for the cable gland is 2.5 Nm. The terminal pin numbers are written on the terminal contact block.

The tightening torque for the screws of the contact block is 0.7 Nm.

The ITL 4000-S transducer should be powered from a typical +24/-24 V power supply, the positive voltage connected to +Vc (terminal 1), the negative voltage to -Vc (terminal 3). Supply ground is not connected to the transducer.

The measuring resistance  $R_M$  should be connected between M (terminal 4) and ground (0 V).

The heatsink and the measuring head are internally connected to the ground terminal (threaded stud) which is accessible on the heatsink side (see fig. 8); it should be connected to the ITL 4000-S local ground.

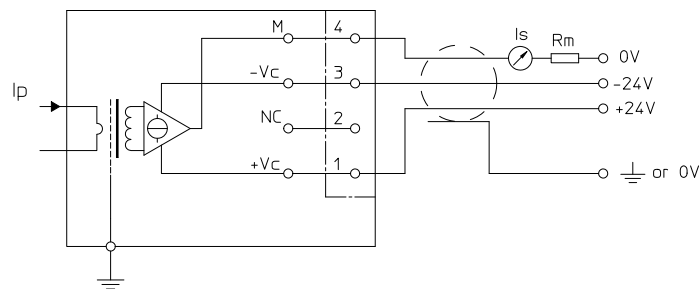

Figure 5: Connection principle

When the distance between the ITL 4000-S and the control device is long, a double screened cable should be used and connected as shown in the schematics below. The external cable screen should be connected to the ITL 4000-S ground; the internal cable screen should be connected to the ground potential which is close to the control device.

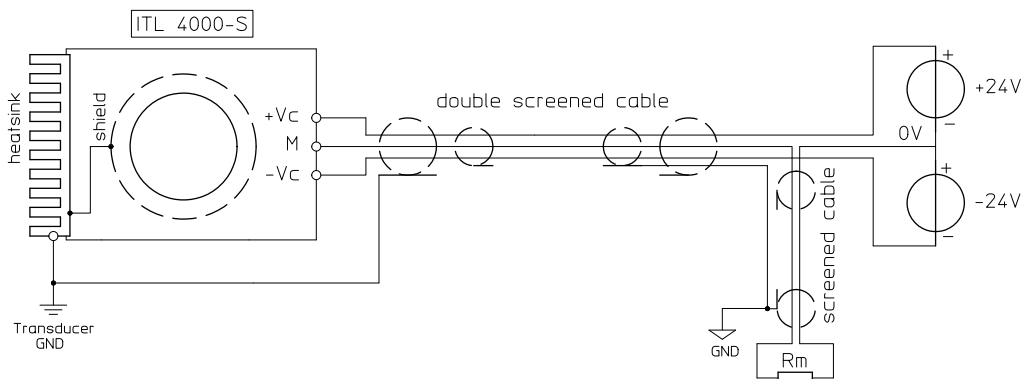

Figure 6: Connection principle

## Electronics module replacement procedure

The electronics module consists of the heatsink and the printed circuit board assembly which is pre-adjusted during manufacturing.

The following procedure must be followed:

- If possible, make sure that the primary current has been switched off.
- Turn off the power supply of the current transducer.
- Remove the 6 screws that hold the heatsink (see fig. 9); the electronics module can be moved away from the housing so as to have an access to the wires and one pin connectors.
- If a primary current is still present, short-circuit the secondary winding of the transducer by engaging the two one pin connectors on the leads to the measuring head.
- Remove the three leads on connector X1 (fig. 7), the six leads on connector X2 (fig. 8) and the shield connection to the heatsink (fig. 8).
- Connect the new electronics module (colors as in fig. 7 and 8). Mounting torque for the earth connection screw is 0.55 Nm and for the terminal screws (3 and 6 leads) it is 0.5 Nm.
- Remove the secondary short circuit if present by disconnecting the one pin connectors.
- Put the heatsink in place (take care not to pinch any leads between heatsink and case) and fasten the 6 screws with a torque of 1.3 Nm.
- Turn on the transducer power supply, turn on the primary circuit.



Figure 7: connector X1

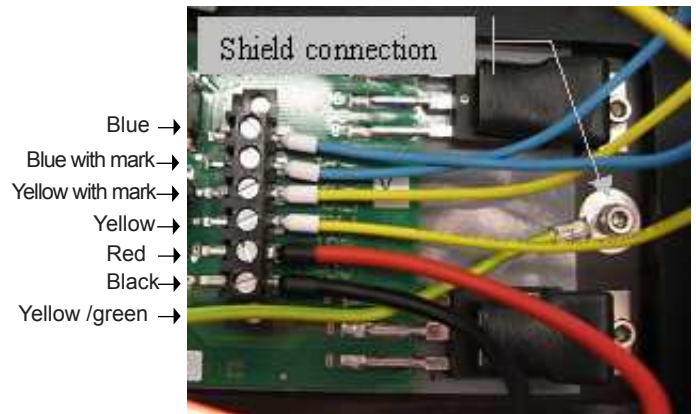

Figure 8: connector X2 and shield connection

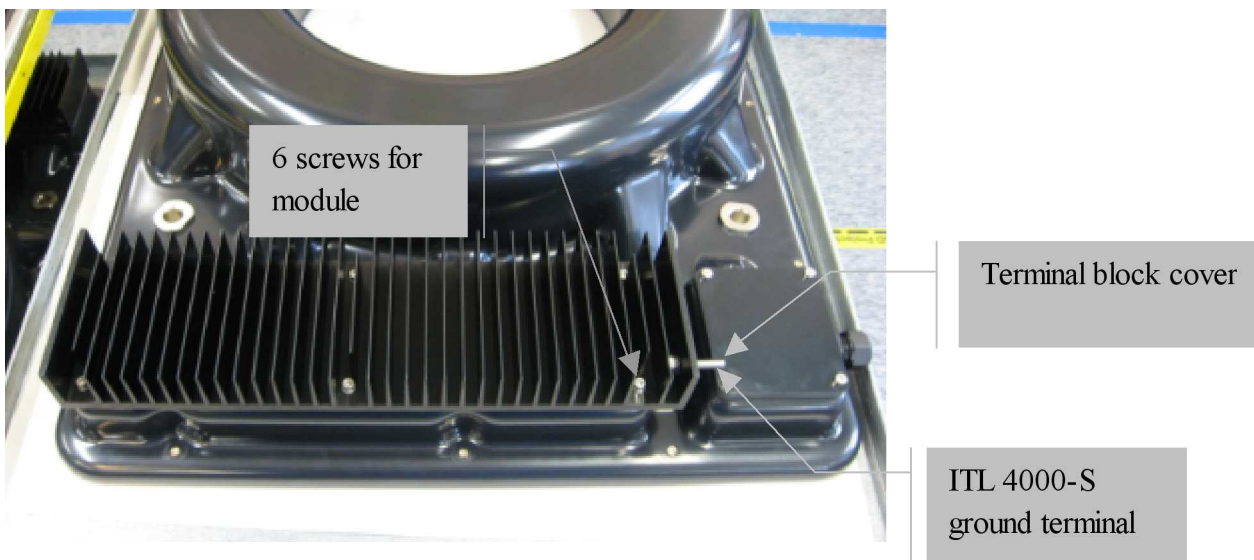
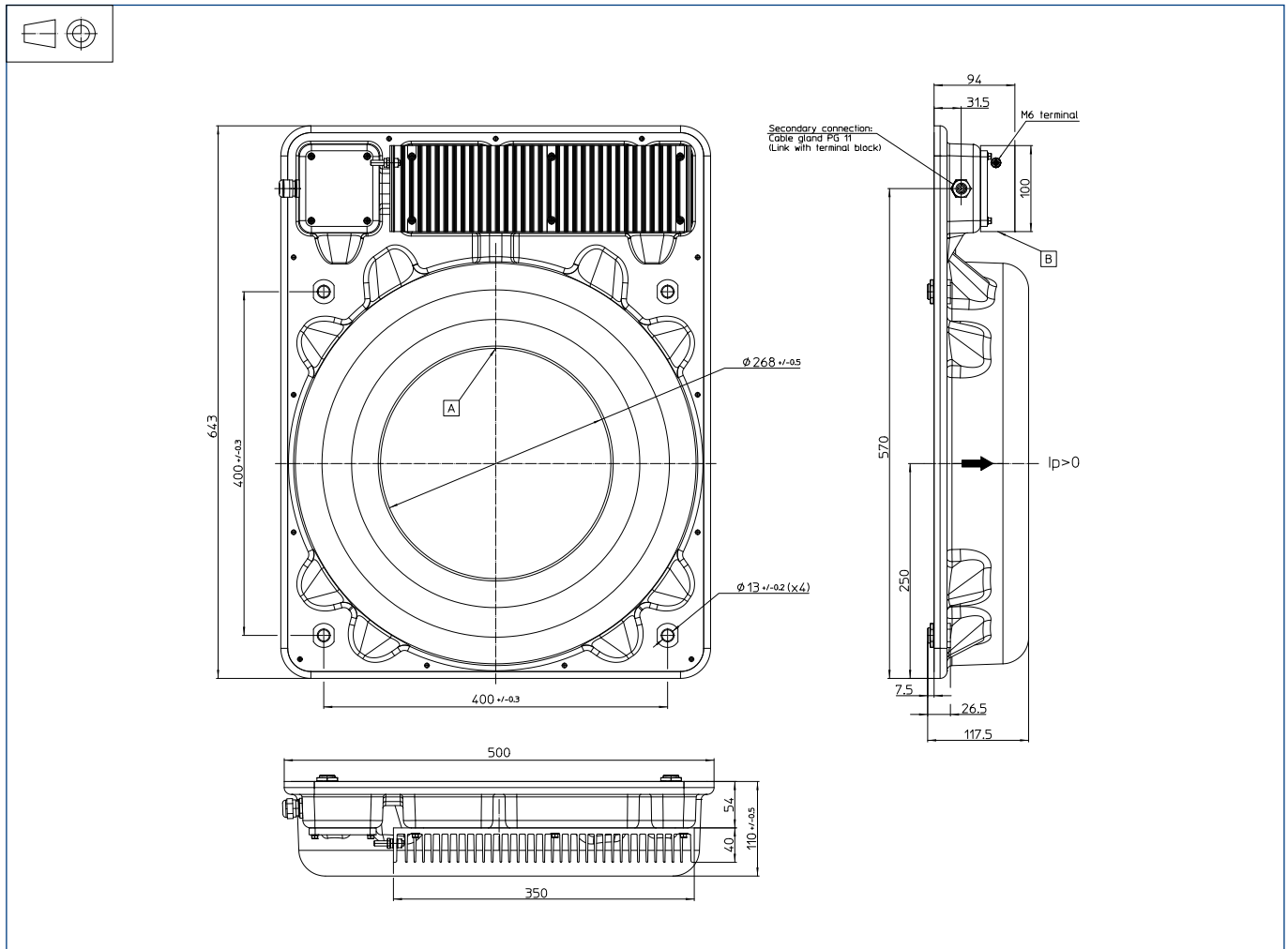

Figure 9: External view of ITL 4000-S

**Dimensions ITL 4000-S** (in mm. General linear tolerance  $\pm 1$  mm)

**Safety**

This transducer must be used in limited-energy circuits according to IEC 61010-1.



This transducer must be used in electric/electronic equipment with respect to applicable standards and safety requirements in accordance with the manufacturer's operating instructions.



Caution, risk of electrical shock

When operating the transducer, certain parts of the module can carry hazardous voltage (eg. primary busbar, power supply). Ignoring this warning can lead to injury and/or cause serious damage.

This transducer is a build-in device, whose conducting parts must be inaccessible after installation.

A protective housing or additional shield could be used.

Main supply must be able to be disconnected.