

1. Features

- ◆ 1.6mm(L)×0.8mm(W) small size surface mount type
- ◆ Thin package of 0.55mm(H) thickness
- ◆ Transparent clear lens optic
- ◆ Low power consumption type chip led
- ◆ Emitting Light Yellow (585nm)

2. Applications

- ◆ LCD backlighting
- ◆ Keypad backlighting
- ◆ Symbol backlighting
- ◆ Front panel indicator lamp

3. Outline Dimensions

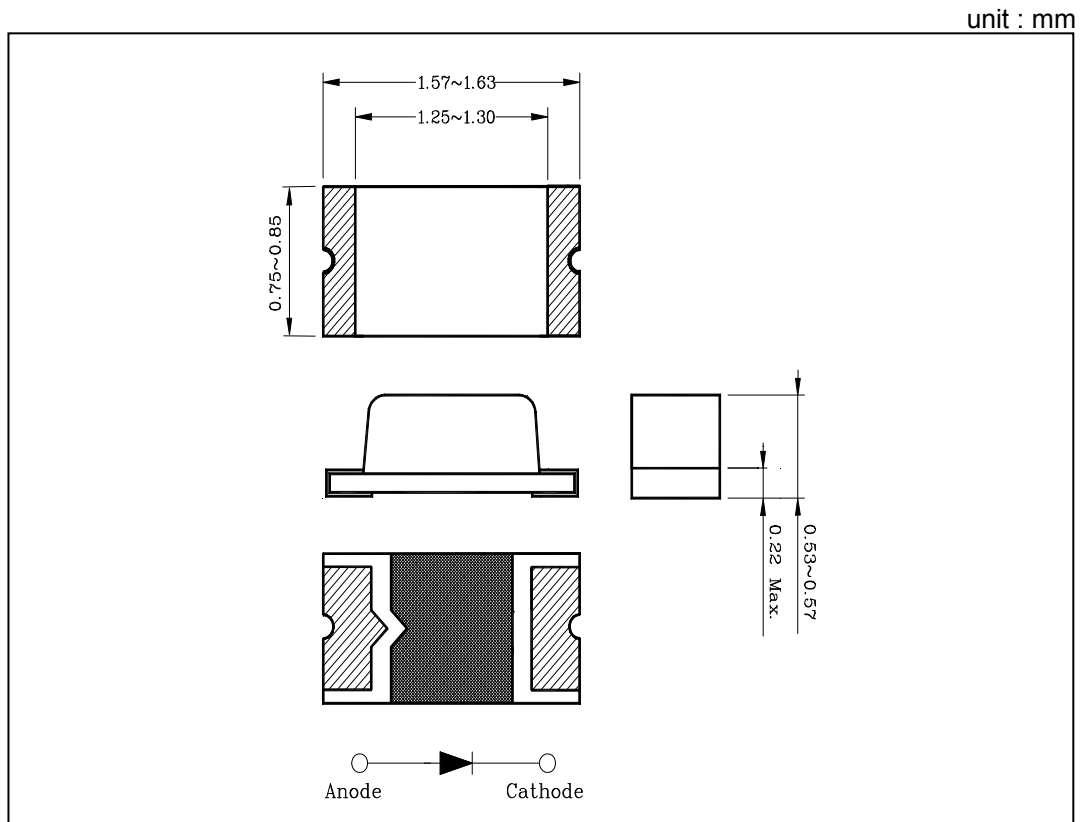

The contents of this data sheet are subject to change without advance notice for the purpose of improvement.
When using this product, would you please refer to the latest specifications.

4. Absolute Maximum Ratings

(Ta=25°C)

| Characteristic | Symbol | Rating | Unit |
|-----------------------------|-----------|----------------------|------|
| Power dissipation | P_D | 60 | mW |
| Forward current | I_F | 25 | mA |
| *1 Peak forward current | I_{FP} | 50 | mA |
| Reverse voltage | V_R | 4 | V |
| Operating temperature range | T_{opr} | -25~80 | °C |
| Storage temperature range | T_{stg} | -30~100 | °C |
| *2 Soldering temperature | T_{sol} | 240°C for 10 seconds | |

*1.Duty ratio = 1/16, Pulse width = 0.1ms

*2.Recommended reflow soldering temperature profile

- Preheating 150°C to 185°C within 120 seconds soldering 240°C within 10 seconds
- Gradual cooling (Avoid quenching)

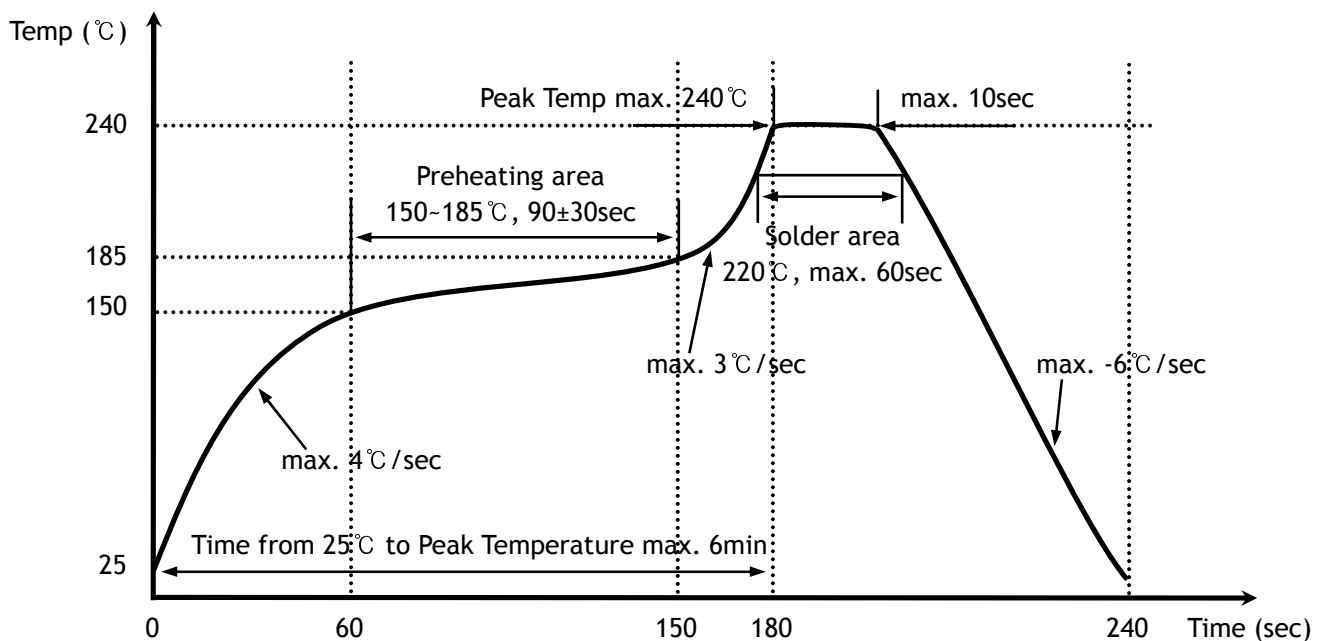

The contents of this data sheet are subject to change without advance notice for the purpose of improvement. When using this product, would you please refer to the latest specifications.

5. Electrical / Optical Characteristics

(Ta=25°C)

| Characteristic | Symbol | Test Condition | Min. | Typ. | Max. | Unit | |
|-----------------------|-----------------|-------------------|-------------------|------|----------|---------------|-----|
| Forward voltage | V_F | $I_F=10\text{mA}$ | - | 2.1 | 2.4 | V | |
| *3 Luminous intensity | I_V | $I_F=10\text{mA}$ | - | 4 | - | mcd | |
| Peak wavelength | λ_P | $I_F=10\text{mA}$ | - | 585 | - | nm | |
| Spectrum bandwidth | $\Delta\lambda$ | $I_F=10\text{mA}$ | - | 30 | - | nm | |
| Reverse current | I_R | $V_R=4\text{V}$ | - | - | 10 | μA | |
| *4 Half angle | $\theta/2$ | X | $I_F=10\text{mA}$ | - | ± 65 | - | deg |
| | | Y | | - | ± 70 | - | |

*3.The test result of $I_F=10\text{mA}$ is only for reference

*4. $\theta/2$ is the off-axis angle where the luminous intensity is 1/2 the peak intensity

*3.Luminous Intensity Classification

| C | D | E |
|---------|---------|---------|
| 1.6~2.6 | 2.6~4.1 | 4.1~6.6 |

(Each I_V range did not consider a margin. Please refer to $\pm 18\%$ of I_V range as a permitted limit and do not use to combine grade classification. It must be used separately grade classification)

* Recommended Soldering Land Pattern

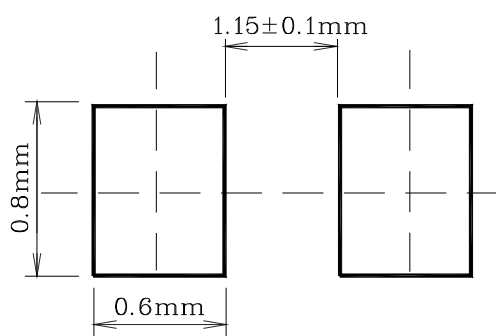

The contents of this data sheet are subject to change without advance notice for the purpose of improvement. When using this product, would you please refer to the latest specifications.

6. Characteristic Diagrams

Fig. 1 $I_F - V_F$

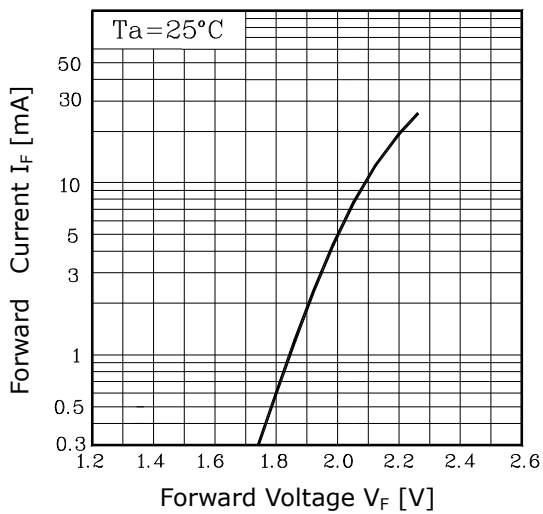

Fig. 2 $I_V - I_F$

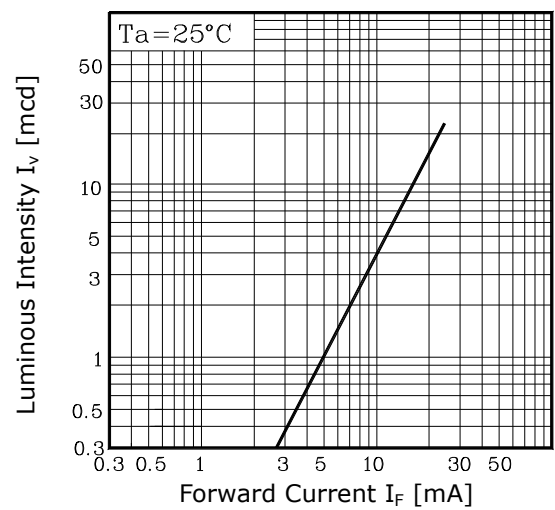

Fig. 3 $I_F - T_a$

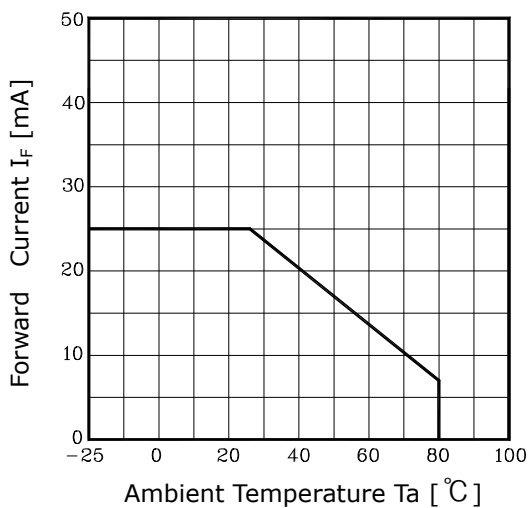

Fig.4 Spectrum Distribution

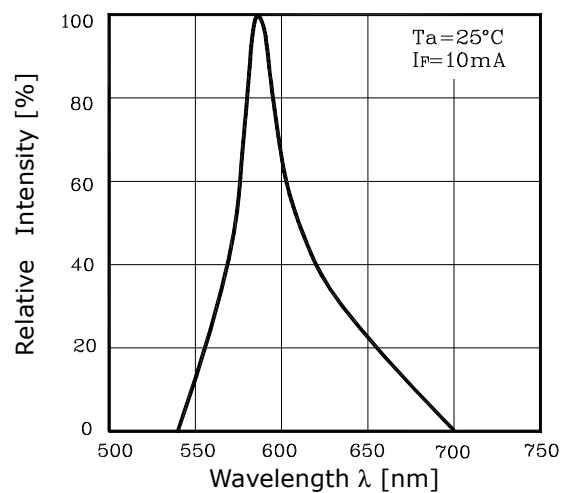

Fig. 5-1 Radiation Diagram(X)

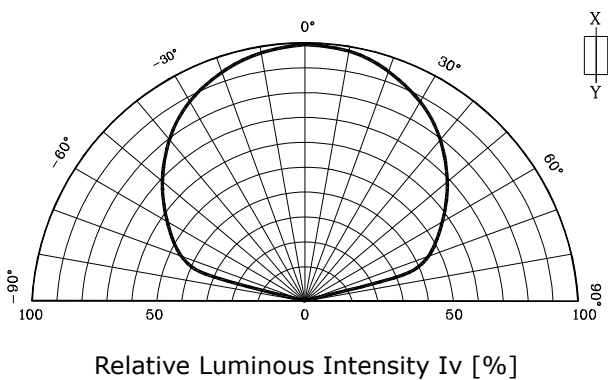
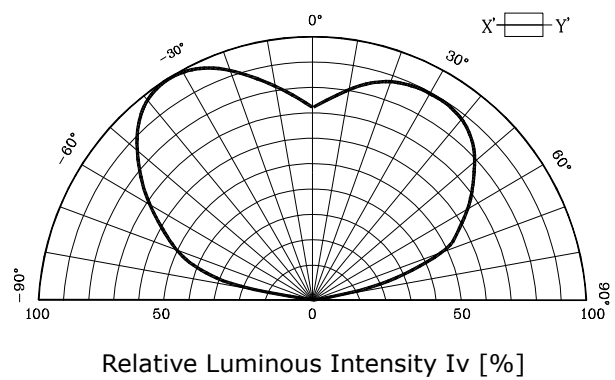

Fig. 5-2 Radiation Diagram(Y)



The contents of this data sheet are subject to change without advance notice for the purpose of improvement. When using this product, would you please refer to the latest specifications.