

SB3317E-G/SB3317E-G(B) *SB3317E-GHF/SB3317E-GHF(B)*1. Features**

- ◆ Colorless transparency lens type
- ◆ ϕ 3mm(T-1) all plastic mold type
- ◆ Super luminosity
- ◆ E ; ESD Protected (\pm 2.0KV, 3 times @100pF, 1.5K Ω)

2. Ordering information

PART NO	Material	Emitting Color	Lens Color	Stopper type	ROHS Compliant
SB3317E-G	InGaN	Blue	Transparent	None	Pb free
SB3317E-G(B)	InGaN	Blue	Transparent	stopper	Pb free
SB3317E-GHF	InGaN	Blue	Transparent	None	Halogen free
SB3317E-GHF(B)	InGaN	Blue	Transparent	stopper	Halogen free

The contents of this data sheet are subject to change without advance notice for the purpose of improvement.
When using this product, would you please refer to the latest specifications.

***SB3317E-G/SB3317E-G(B) *SB3317E-GHF/SB3317E-GHF(B)**

3. Outline Dimensions

unit : mm

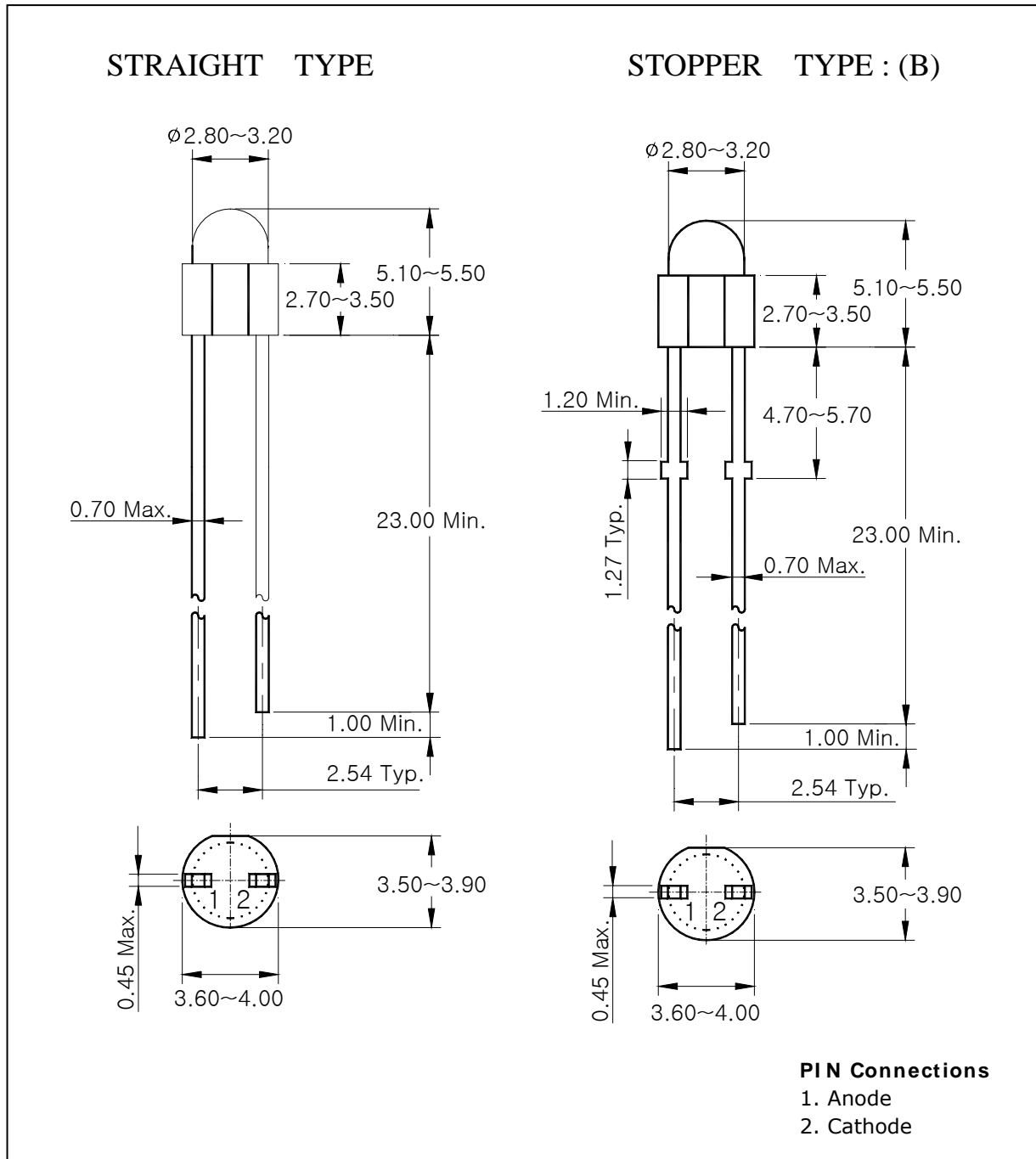

The contents of this data sheet are subject to change without advance notice for the purpose of improvement. When using this product, would you please refer to the latest specifications.

SB3317E-G/SB3317E-G(B) *SB3317E-GHF/SB3317E-GHF(B)*4. Absolute Maximum Ratings**

(Ta=25°C)

Characteristic	Symbol	Rating	Unit
Power dissipation	P_D	75	mW
Forward current	I_F	20	mA
*1 Peak forward current	I_{FP}	50	mA
Reverse voltage	V_R	4	V
Operating temperature range	T_{opr}	-25~85	°C
Storage temperature range	T_{stg}	-30~100	°C
*2 Soldering temperature	T_{sol}	260°C for 10 seconds	

*1. Duty ratio = 1/16, Pulse width = 0.1ms

*2. Keep the distance more than 2.0mm from PCB to the bottom of LED package

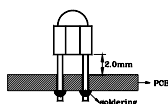

※ Recommend document

-. LED is very sensitive to ESD.

5. Electrical / Optical Characteristics

(Ta=25°C)

Characteristic	Symbol	Test Condition	Min.	Typ.	Max.	Unit
Forward voltage	V_F	$I_F = 20\text{mA}$	2.9	-	3.8	V
*4 Luminous intensity	I_V	$I_F = 20\text{mA}$	350	-	1760	mcd
Dominant wavelength	λ_D	$I_F = 20\text{mA}$	460	468	475	nm
Spectrum bandwidth	$\Delta\lambda$	$I_F = 20\text{mA}$	-	26	-	nm
Reverse current	I_R	$V_R = 4\text{V}$	-	-	10	uA
*3 Half angle	$\theta_{1/2}$	$I_F = 20\text{mA}$	-	± 22	-	deg

*3. $\theta_{1/2}$ is the off-axis angle where the luminous intensity is 1/2 the peak intensity*4. Luminous intensity maximum tolerance for each grade classification limit is $\pm 18\%$

The contents of this data sheet are subject to change without advance notice for the purpose of improvement.
When using this product, would you please refer to the latest specifications.

***SB3317E-G/SB3317E-G(B) *SB3317E-GHF/SB3317E-GHF(B)**◆ $V_F / I_V / \lambda_D$ Grade Classification (Ta=25°C)

Test Condition @ $I_F = 20\text{mA}$		
Forward Voltage [V]	Luminous Intensity [mcd]	Dominant Wavelength [nm]
1 : 2.9~3.2	O : 350~520	a : 460~465
	P : 520~780	
2 : 3.2~3.5	Q : 780~1170	b : 465~470
	R : 1170~1760	
3 : 3.5~3.8		c : 470~475

(Do not use to combine grade classification. It must be used separately grade classification)

The contents of this data sheet are subject to change without advance notice for the purpose of improvement.
When using this product, would you please refer to the latest specifications.

6. Characteristic Diagrams

Fig. 1 $I_F - V_F$

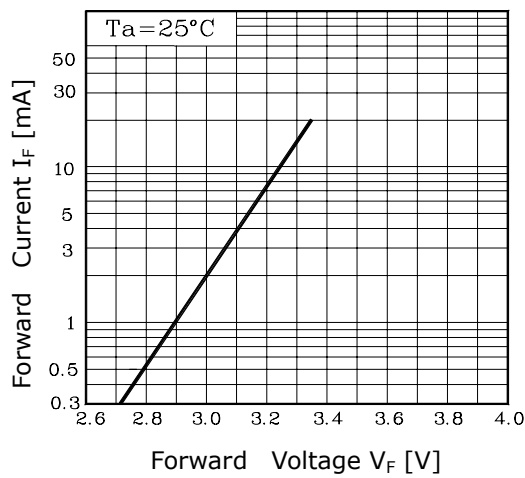

Fig. 2 $I_V - I_F$

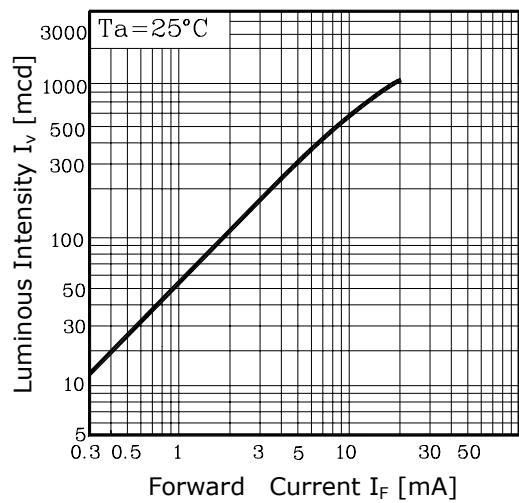

Fig. 3 $I_F - T_a$

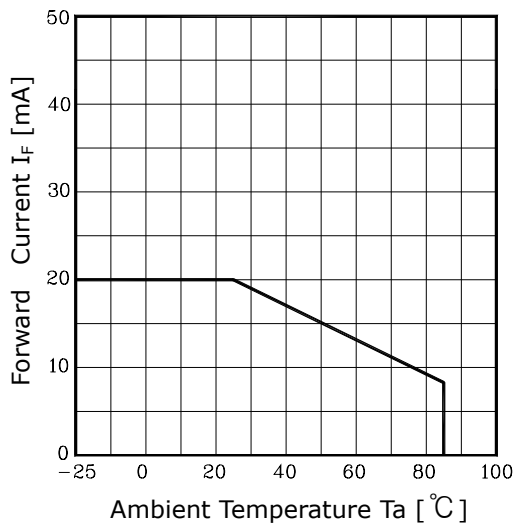

Fig.4 Spectrum Distribution

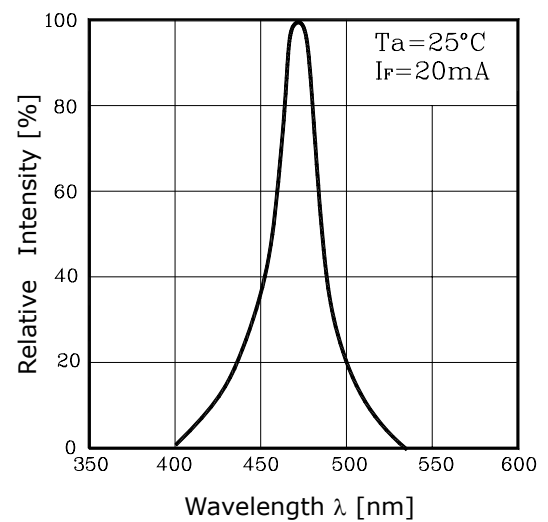
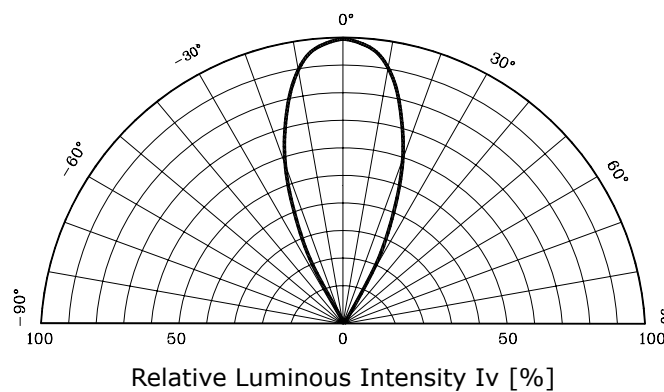

Fig. 5 Radiation Diagram



The contents of this data sheet are subject to change without advance notice for the purpose of improvement. When using this product, would you please refer to the latest specifications.