

### 1. Features

- ◆ Surface Mount Package ( 9.0 L × 9.0 W × 3.0 H [mm])
- ◆ Operation Temperature from -40℃ to +85℃
- ◆ Typical Total Radiant Flux( $\Phi_e$ ) : 6 lm @ IF = 350 mA.

### 2. Applications

- ◆ Decorative and design lighting
- ◆ Spot lighting
- ◆ Illumination for horticulture

### 3. Outline Dimensions and Material Descriptions

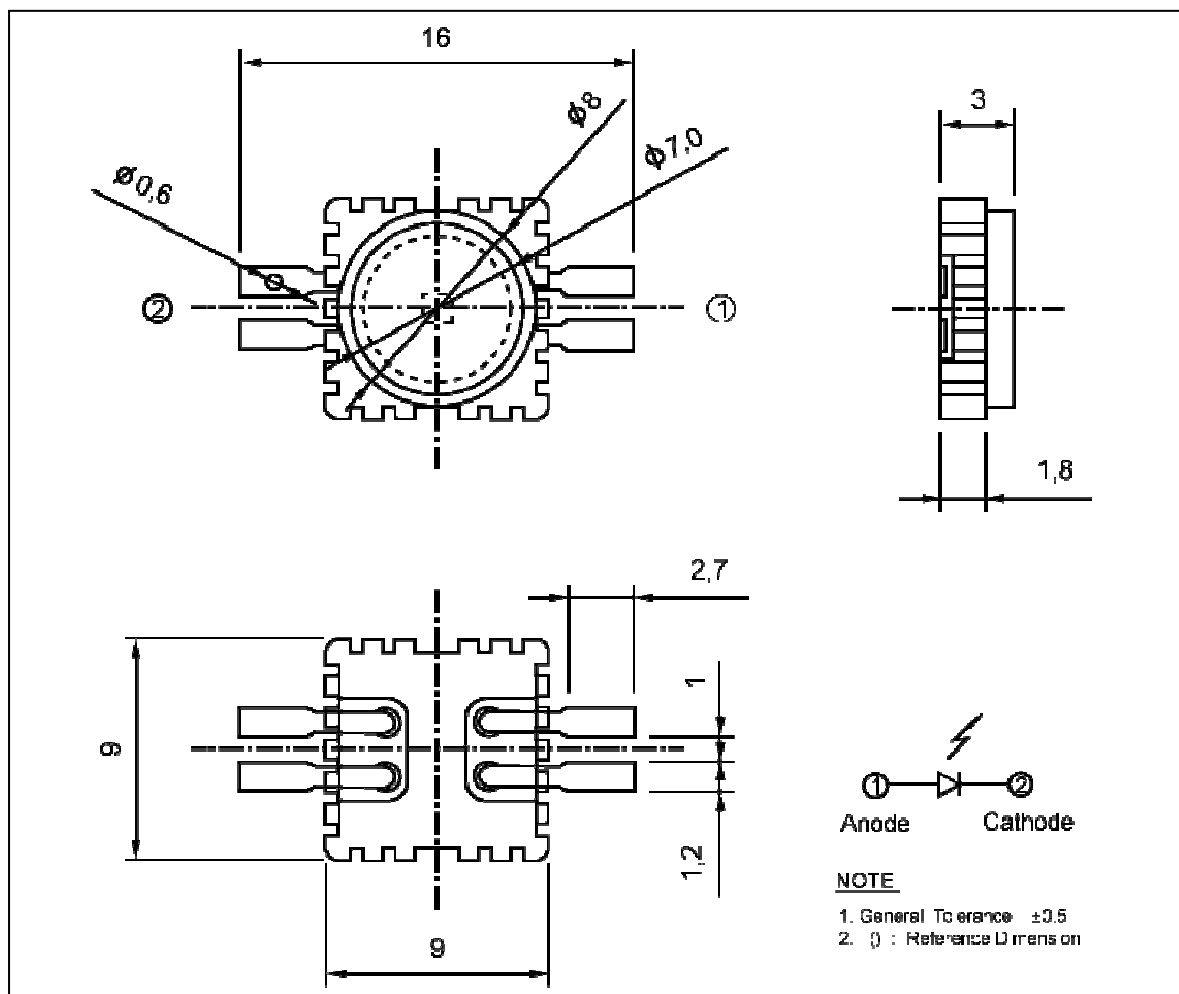

The contents of this data sheet are subject to change without advance notice for the purpose of improvement. When using this product, would you please refer to the latest specifications.

## ◆ Material Descriptions

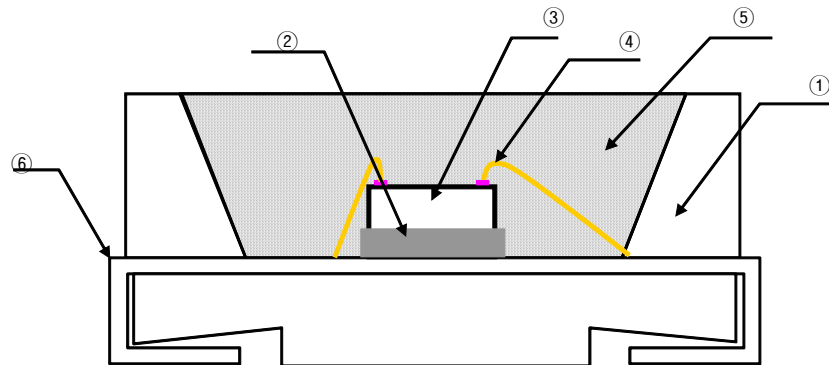

No.	ITEM	Material
①	Frame	Al
②	Paste	Ag Epoxy
③	LED Chip	AllnGaP
④	Wire	Au
⑤	Encapsulant	Silicone
⑥	Electrode	Ag Plated Cu

## 4. Absolute Maximum

(Ta=25°C)

Parameter	Symbol	Ratings	Unit
Forward current	$I_F$	350	mA
Pulse forward current *1	$I_{FP}$	700	mA
Power dissipation	$P_D$	1.0	W
Operating temperature	$T_{opr.}$	-40 ~ +85	°C
Storage temperature	$T_{stg.}$	-40 ~ +100	°C
Soldering Temperature *2	$T_{sol.}$	260	°C

\* 1.  $I_{FP}$  Measured under duty  $\leq 1/10$  @ 1KHz\* 2. Soldering time  $\leq 5$  Sec

## 5. Electrical / Optical Characteristics

(Ta=25°C)

Parameter	Symbol	Conditions	Min	Typ	Max	Unit
Forward voltage	$V_F$	$I_F = 350\text{mA}$	-	2.6	-	V
Reverse current	$I_R$	$V_R = 5\text{V}$	-	10	-	$\mu\text{A}$
Peak wavelength	$\lambda_p$	$I_F = 350\text{mA}$	-	660	-	nm
Luminous Flux	$\Phi_e$	$I_F = 350\text{mA}$	-	6	-	lm
Half angle	$2\Delta\theta_{1/2}$	$I_F = 350\text{mA}$	-	120	-	deg.

The contents of this data sheet are subject to change without advance notice for the purpose of improvement.  
When using this product, would you please refer to the latest specifications.

6. Characteristic Graphs

Power dissipation Vs. Ambient temperature

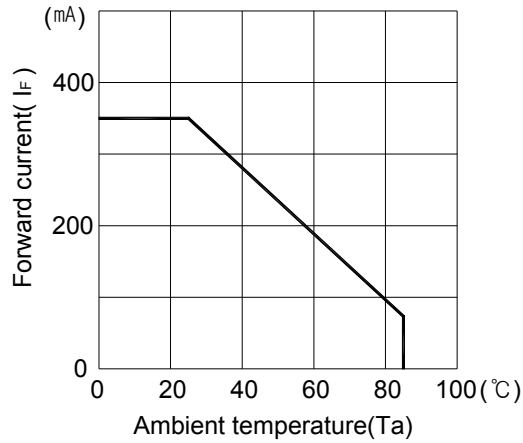

Relative intensity Vs. Forward current

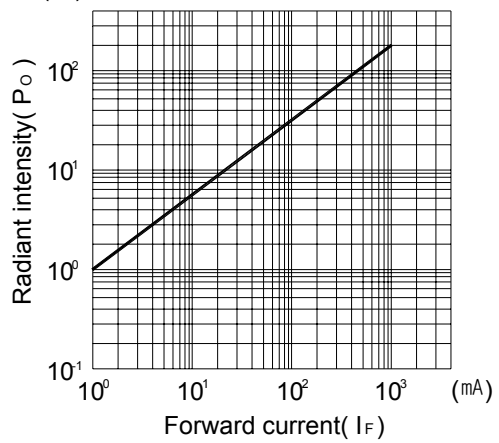

Forward current Vs. Forward voltage

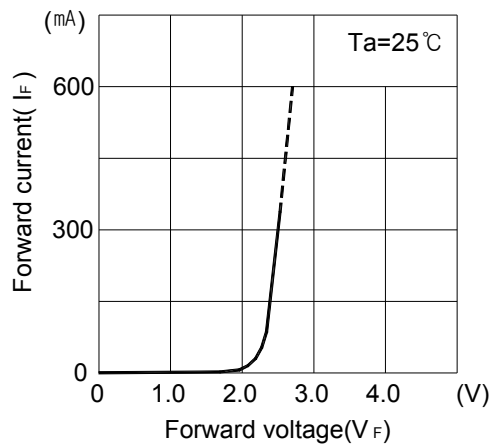

Relative intensity Vs. Wavelength

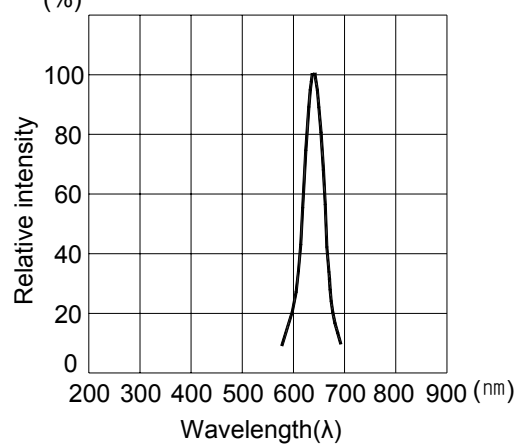

Relative luminous flux Vs. Ambient temperature

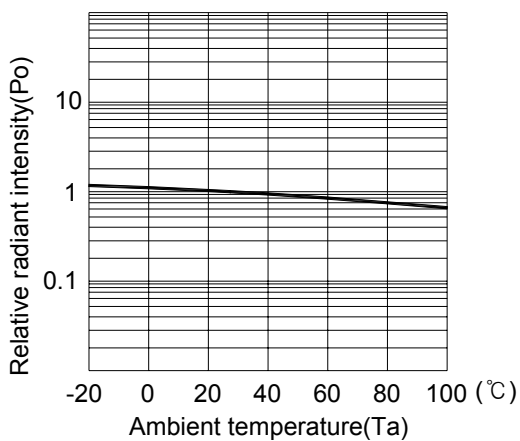

Radiant Pattern

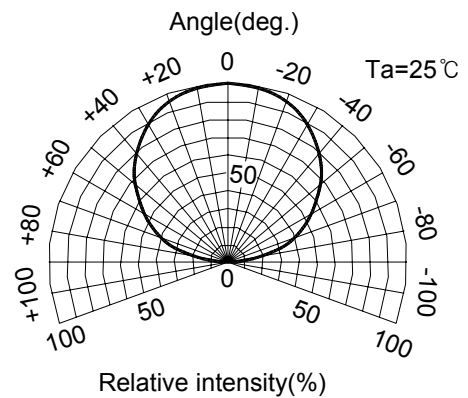

The contents of this data sheet are subject to change without advance notice for the purpose of improvement. When using this product, would you please refer to the latest specifications.