

1. Features

- ◆ Transparent epoxy lens
- ◆ High Optical Output

2. Applications

- ◆ Display
- ◆ Indicator
- ◆ Signage
- ◆ Camera

2. Outline Dimensions

unit : mm

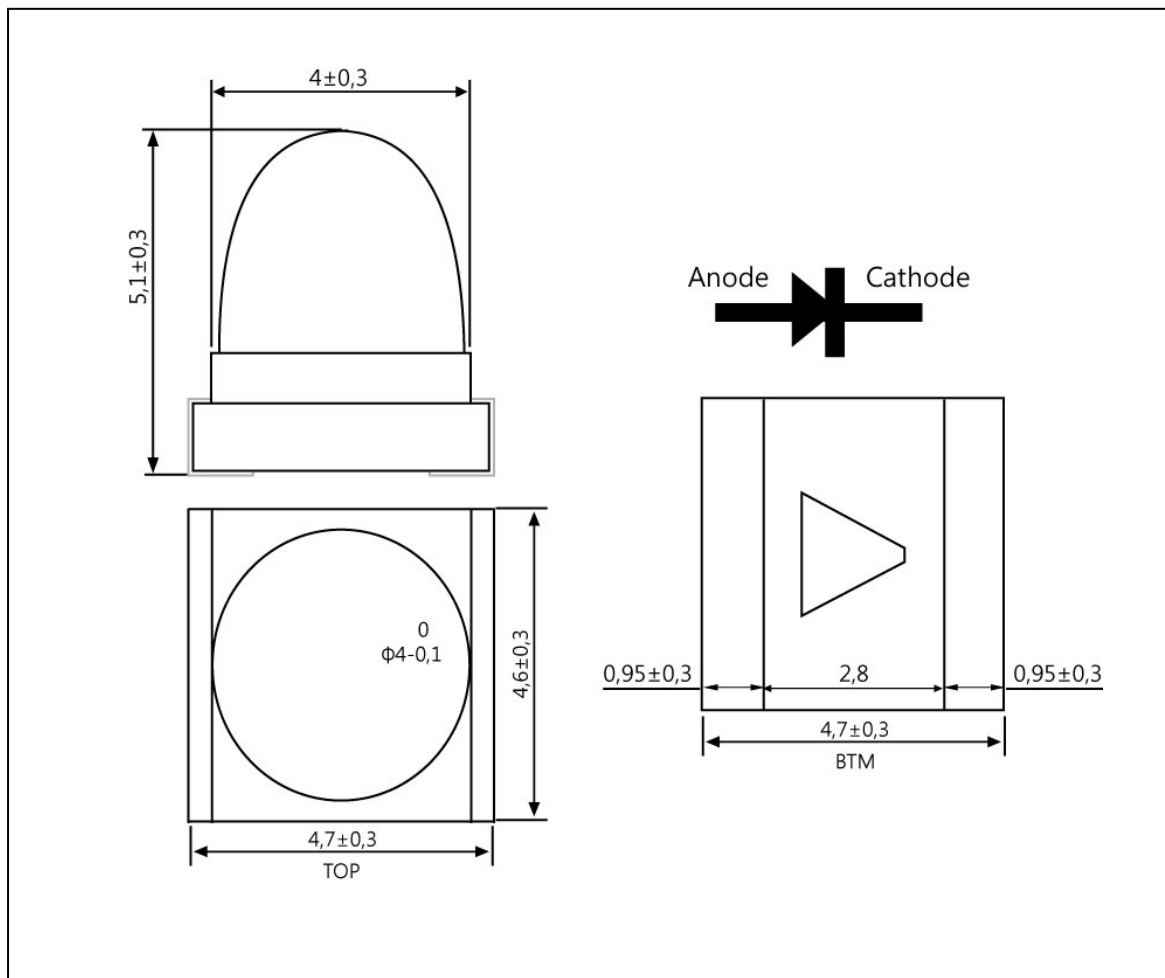

The contents of this data sheet are subject to change without advance notice for the purpose of improvement.
When using this product, would you please refer to the latest specifications.

3. Maximum Ratings

(Ta=25°C)

Parameter	Symbol	Rating	Unit
Reverse voltage	V_R	5	V
Forward current	I_F	30	mA
*1Pulse forward current	I_{FP}	0.5	A
Power dissipation	P_D	105	mW
Operating temperature	T_{opr}	-30 ~ +85	°C
Storage temperature	T_{stg}	-40 ~ +100	°C
*2Soldering temperature	T_{sol}	260	°C

*1. I_{FP} Measured under duty $\leq 1/10$ @ 1KHz*2. Soldering time ≤ 5 Sec

Keep the distance more than 3mm from soldering foundation.

4. Electrical / Optical Characteristics

(Ta=25°C)

Parameter	Symbol	Conditions	Min	Typ	Max	Unit
Forward voltage	V_F	$I_F = 20$ mA	-	3.2	3.5	V
Reverse current	I_R	$V_R = 5$ V	-	-	50	uA
Luminous Intensity	I_V	$I_F = 20$ mA	15	20	-	cd
Peak emission wavelength	λ_p	$I_F = 20$ mA	-	520	-	Nm
Doninant Wave Length	Λ_d	$I_F = 20$ mA	520	-	530	Nm
Spectral half bandwidth	$\Delta\lambda$	$I_F = 20$ mA	-	15	-	Nm
Half angle	$2\Delta\theta_{1/2}$	$I_F = 20$ mA	-	8	-	deg.

The contents of this data sheet are subject to change without advance notice for the purpose of improvement.
When using this product, would you please refer to the latest specifications.

5. Characteristic Diagrams

Forward current vs. Ambient temperature

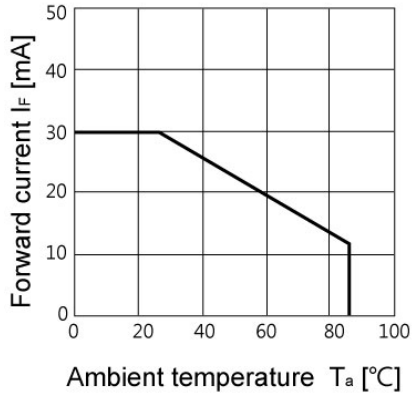

Radiant Intensity vs. Forward current

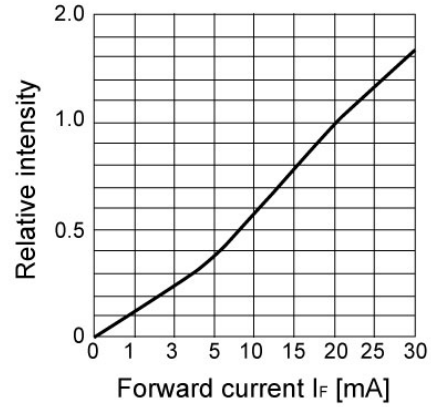

Relative radiant intensity vs. Ambient temperature

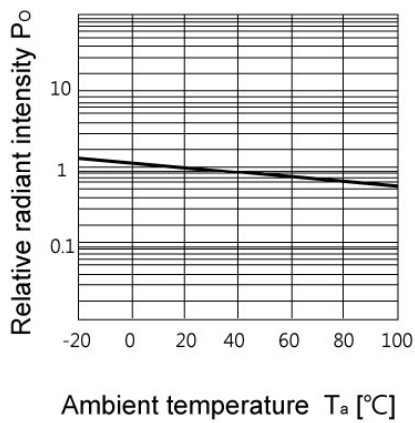

Relative Intensity vs. Wavelength

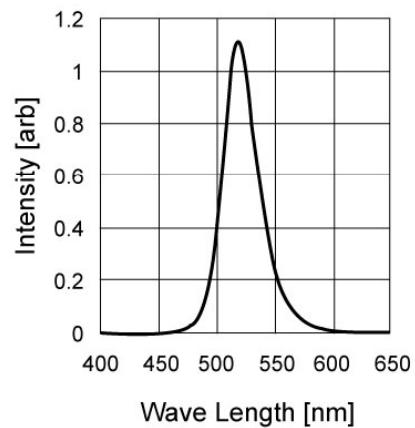

Forward current vs. Forward voltage

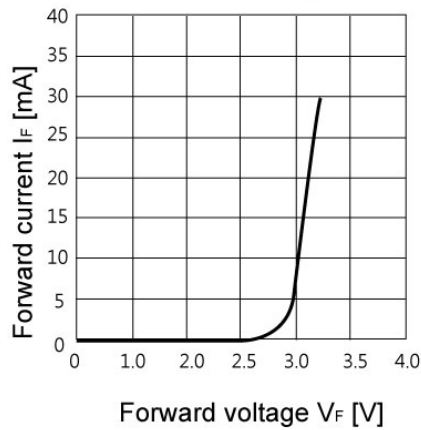

Radiant Pattern

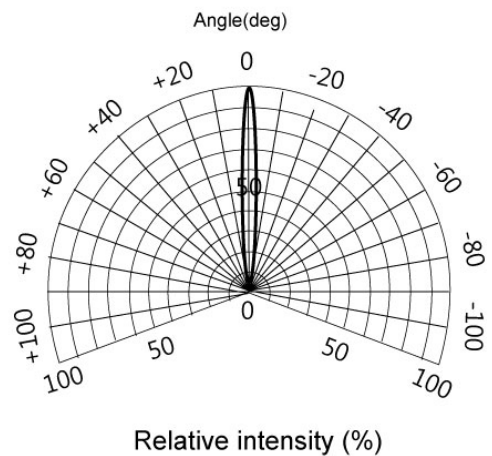

The contents of this data sheet are subject to change without advance notice for the purpose of improvement. When using this product, would you please refer to the latest specifications.