

Descriptions

- General purpose amplifier
- Recommended for LED Drive Application

Features

- Thermally Enhanced Power PKG
- Low saturation voltage: $V_{CE(sat)} = -0.15V$ Typ.
@ $I_C = -1A$, $I_B = -50mA$
- Large collector current capacity: $I_C = -2A$
- 2 PNP chips in TESOP-8 Package

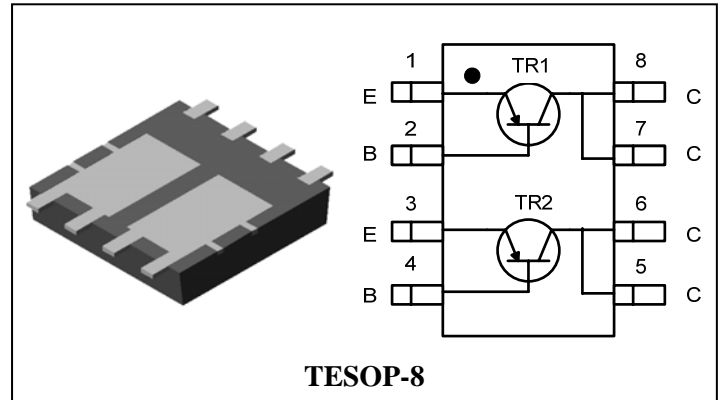

Ordering Information

Type NO.	Marking	Package Code
SUTP052G	SUTP052□	TESOP-8

□ : Year & Week Code

Absolute maximum ratings(TR1, TR2)

($T_a = 25^\circ C$)

Characteristic	Symbol	Ratings	Unit
Collector-base voltage	V_{CBO}	-50	V
Collector-emitter voltage	V_{CEO}	-50	V
Emitter-base voltage	V_{EBO}	-5	V
Collector current	I_C	-2	A(DC)
	I_{CP}^*	-4	A(Pulse)
Collector power dissipation	$P_C(T_a = 25^\circ C)^{**}$	0.75	W/TOTAL
		0.55	W/ELEMENT
	$P_C(T_c = 25^\circ C)$	7.5	W/TOTAL
Junction temperature	T_J	150	$^\circ C$
Storage temperature	T_{stg}	-55~150	$^\circ C$

* : Single pulse, $t_p = 300 \mu s$

** : Each terminal mounted on a recommended solder land

Electrical Characteristics(TR1, TR2)

Characteristic		Symbol	Test Condition	Min.	Typ.	Max.	Unit
Collector-emitter breakdown voltage		BV_{CEO}	$I_C = -1\text{mA}, I_B = 0$	-50	-	-	V
Collector cut-off current		I_{CBO}	$V_{CB} = -50\text{V}, I_E = 0$	-	-	-0.1	μA
Emitter cut-off current		I_{EBO}	$V_{EB} = -5\text{V}, I_C = 0$	-	-	-0.1	μA
DC current gain		$h_{FE}^{1)}$	$V_{CE} = -2\text{V}, I_C = -0.5\text{A}^*$	120	-	240	
		h_{FE}	$V_{CE} = -2\text{V}, I_C = -1.5\text{A}^*$	40	-	-	
Collector-emitter saturation voltage		$V_{CE(sat)}$	$I_C = -1\text{A}, I_B = -0.05\text{A}^*$	-	-	-0.35	V
Base-emitter saturation voltage		$V_{BE(sat)}$	$I_C = -1\text{A}, I_B = -0.05\text{A}^*$	-	-	-1.2	V
Transition frequency		f_T	$V_{CE} = -2\text{V}, I_C = -0.05\text{A}$	-	215	-	MHz
Collector output capacitance		C_{ob}	$V_{CB} = -10\text{V}, I_E = 0, f = 1\text{MHz}$	-	24	-	pF
Switching Time	Turn-on Time	t_{on}		-	100	-	nS
	Storage Time	t_{stg}		-	300	-	
	Fall Time	t_f		-	50	-	

Note 1) h_{FE} Rank : 120~240 only

*: Pulse test : $t_p \leq 300\mu\text{s}$, Duty cycle $\leq 2\%$

Electrical Characteristic Curves(TR1, TR2)

Fig. 1 $P_C - T_a$

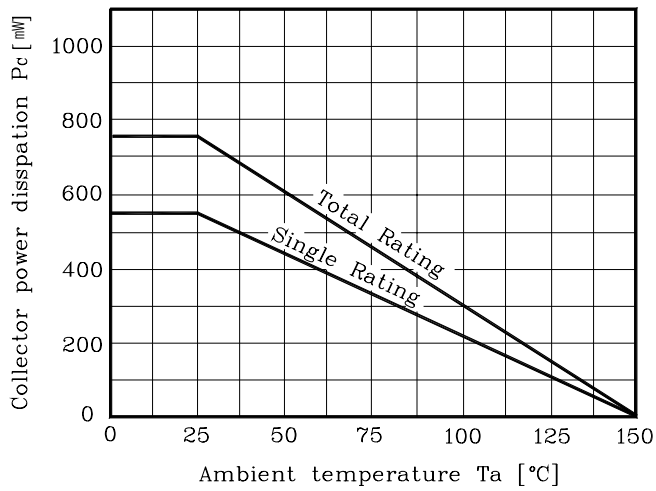

Fig. 2 $I_C - V_{BE}$

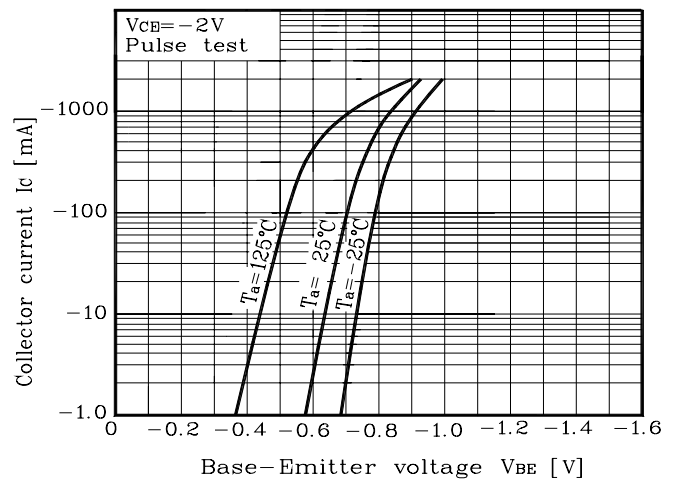

Fig. 3 $I_C - V_{CE}$

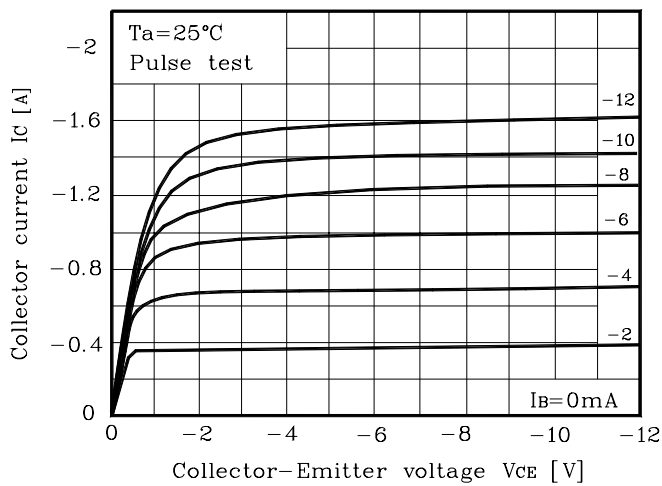

Fig. 4 $h_{FE} - I_C$

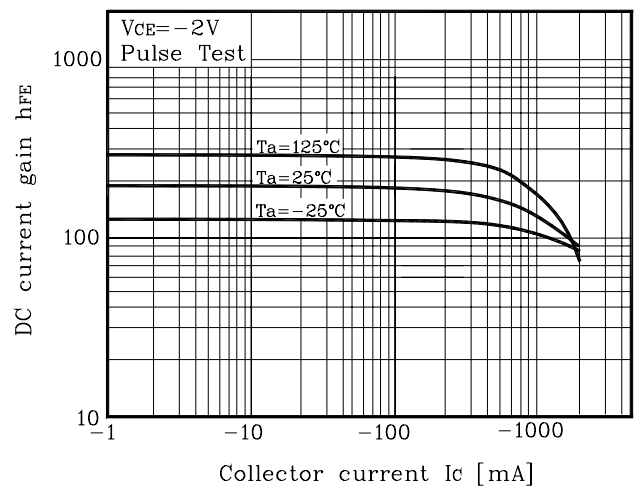

Fig. 5 $V_{CE(sat)} - I_C$

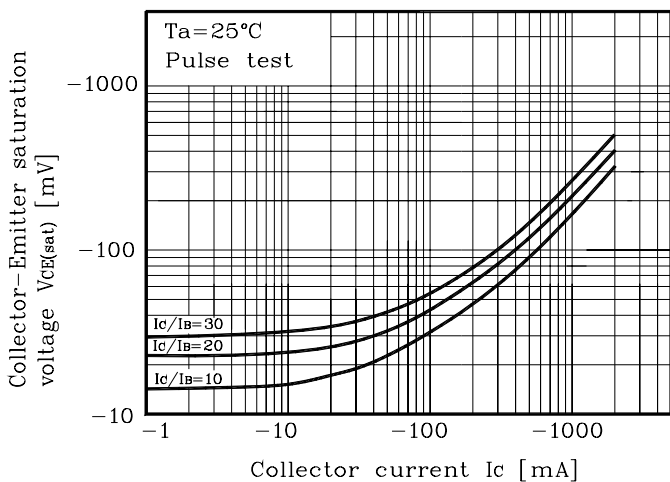
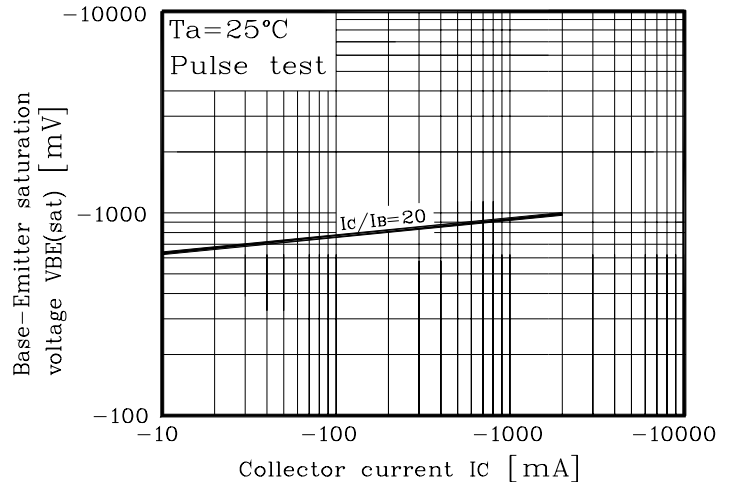

Fig. 6 $V_{BE(sat)} - I_C$



Electrical Characteristic Curves(TR1, TR2)

Fig. 7 $C_{ob} - V_{CB}$

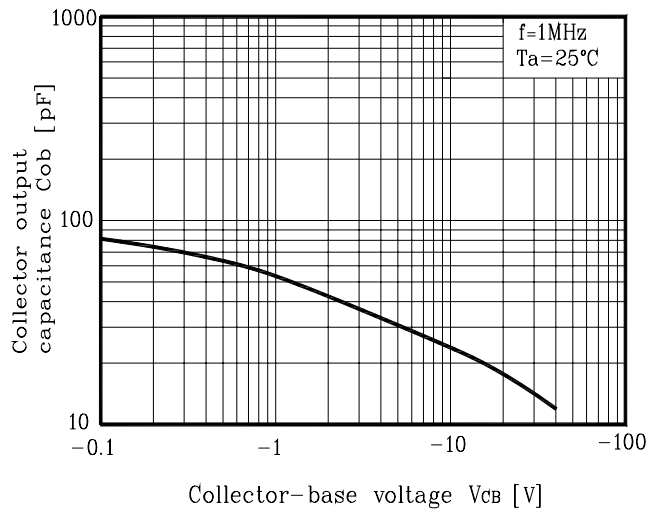
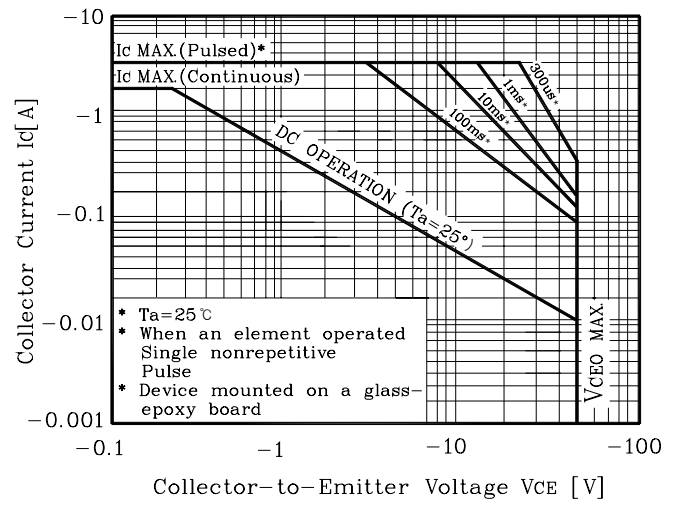

Fig. 8 Safe Operating Area



The AUK Corp. products are intended for the use as components in general electronic equipment (Office and communication equipment, measuring equipment, home appliance, etc.).

Please make sure that you consult with us before you use these AUK Corp. products in equipments which require high quality and / or reliability, and in equipments which could have major impact to the welfare of human life(atomic energy control, airplane, spaceship, transportation, combustion control, all types of safety device, etc.). AUK Corp. cannot accept liability to any damage which may occur in case these AUK Corp. products were used in the mentioned equipments without prior consultation with AUK Corp..

Specifications mentioned in this publication are subject to change without notice.