

## Descriptions

- Complex type bipolar transistor

## Features

- Reduce quantity of parts and mounting cost
- High collector power dissipation :  $P_C=300\text{mW}(\text{Max.})$
- Both 2SA1980 chip and 2SC5343 chip in SOT-26 Package

## Ordering Information

| Type NO. | Marking | Package Code |
|----------|---------|--------------|
| SUT462N  | 3X□     | SOT-26       |

□ : Year & Week Code

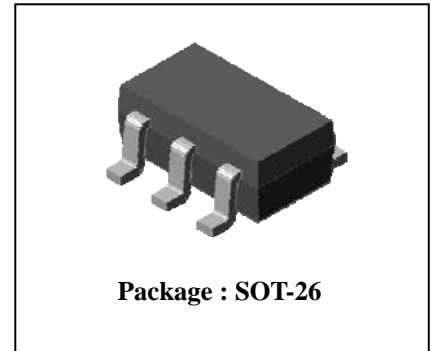

## Equivalent circuit & PIN Connections

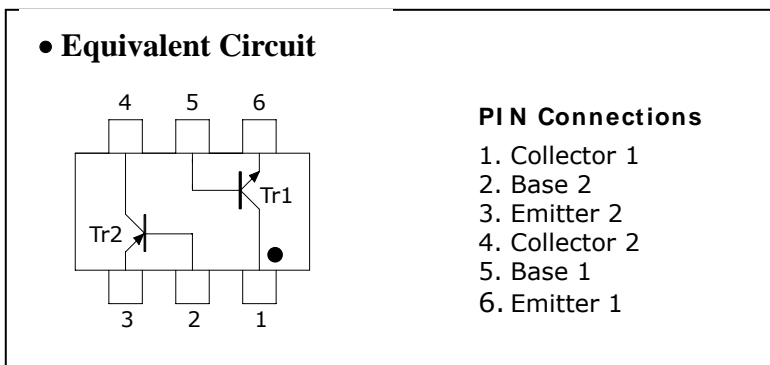

## Absolute Maximum Ratings [Tr1, Tr2]

( $T_a=25^\circ\text{C}$ )

| Characteristic              | Symbol    | Rating  |      | Unit             |
|-----------------------------|-----------|---------|------|------------------|
|                             |           | Tr1     | Tr2  |                  |
| Collector-base voltage      | $V_{CBO}$ | 60      | -50  | V                |
| Collector-emitter voltage   | $V_{CEO}$ | 50      | -50  | V                |
| Emitter-base voltage        | $V_{EBO}$ | 5       | -5   | V                |
| Collector current           | $I_C$     | 150     | -150 | mA               |
| Collector power dissipation | $P_C^*$   | 300     |      | mW               |
| Junction temperature        | $T_J$     | 150     |      | $^\circ\text{C}$ |
| Storage temperature range   | $T_{stg}$ | -55~150 |      | $^\circ\text{C}$ |

※: Total rating(Each terminal mounted on a recommended solder land)

## Electrical Characteristics [Tr1]

(Ta=25°C)

| Characteristic                       | Symbol        | Test Condition                            | Min. | Typ. | Max. | Unit          |
|--------------------------------------|---------------|---|------|------|------|---------------|
| Collector-emitter breakdown voltage  | $BV_{CEO}$    | $I_C=1\text{mA}, I_B=0$                   | 50   | -    | -    | V             |
| Collector cut-off current            | $I_{CBO}$     | $V_{CB}=60\text{V}, I_E=0$                | -    | -    | 0.1  | $\mu\text{A}$ |
| Emitter cut-off current              | $I_{EBO}$     | $V_{EB}=5\text{V}, I_C=0$                 | -    | -    | 0.1  | $\mu\text{A}$ |
| DC current gain                      | $h_{FE}$      | $V_{CE}=6\text{V}, I_C=2\text{mA}$        | 120  | -    | 400  | -             |
| Collector-emitter saturation voltage | $V_{CE(sat)}$ | $I_C=100\text{mA}, I_B=10\text{mA}$       | -    | -    | 0.25 | V             |
| Base-emitter voltage                 | $V_{BE}$      | $V_{CE}=6\text{V}, I_C=2\text{mA}$        | -    | 0.65 | -    | V             |
| Transition frequency                 | $f_T$         | $V_{CE}=10\text{V}, I_C=10\text{mA}$      | -    | 200  | -    | MHz           |
| Collector output capacitance         | $C_{ob}$      | $V_{CB}=10\text{V}, I_E=0, f=1\text{MHz}$ | -    | 2    | -    | pF            |

## Electrical Characteristics [Tr2]

(Ta=25°C)

| Characteristic                       | Symbol        | Test Condition                             | Min. | Typ.  | Max. | Unit          |
|--------------------------------------|---------------|--|------|-------|------|---------------|
| Collector-emitter breakdown voltage  | $BV_{CEO}$    | $I_C=-1\text{mA}, I_B=0$                   | -50  | -     | -    | V             |
| Collector cut-off current            | $I_{CBO}$     | $V_{CB}=-50\text{V}, I_E=0$                | -    | -     | -0.1 | $\mu\text{A}$ |
| Emitter cut-off current              | $I_{EBO}$     | $V_{EB}=-5\text{V}, I_C=0$                 | -    | -     | -0.1 | $\mu\text{A}$ |
| DC current gain                      | $h_{FE}$      | $V_{CE}=-6\text{V}, I_C=-2\text{mA}$       | 120  | -     | 400  | -             |
| Collector-emitter saturation voltage | $V_{CE(sat)}$ | $I_C=-100\text{mA}, I_B=-10\text{mA}$      | -    | -     | -0.3 | V             |
| Base-emitter voltage                 | $V_{BE}$      | $V_{CE}=-6\text{V}, I_C=-2\text{mA}$       | -    | -0.65 | -    | V             |
| Transition frequency                 | $f_T$         | $V_{CE}=-10\text{V}, I_C=-10\text{mA}$     | -    | 200   | -    | MHz           |
| Collector output capacitance         | $C_{ob}$      | $V_{CB}=-10\text{V}, I_E=0, f=1\text{MHz}$ | -    | 4     | -    | pF            |

Electrical Characteristic Curves

[Tr1]

Fig. 1  $I_C - V_{BE}$

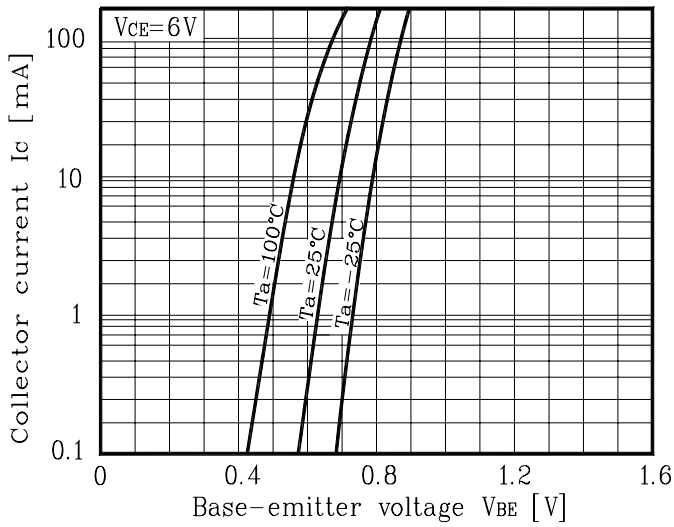

Fig. 2  $I_C - V_{CE}$

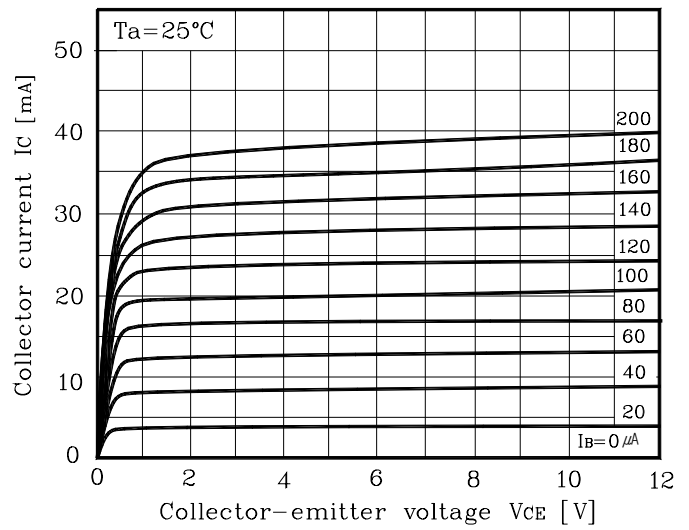

Fig. 3  $h_{FE} - I_C$

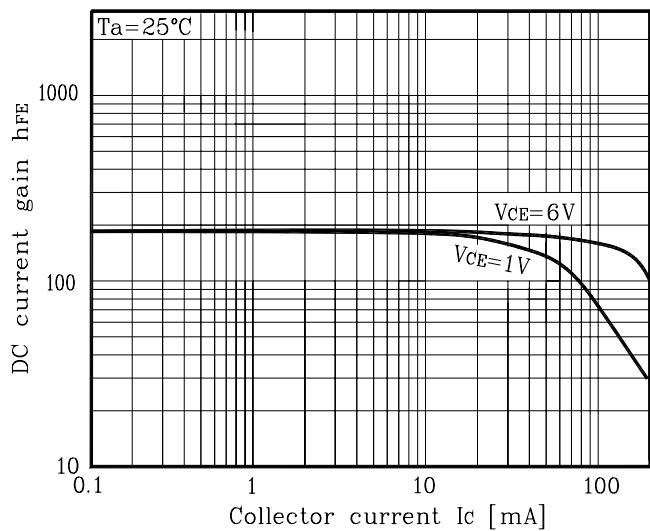
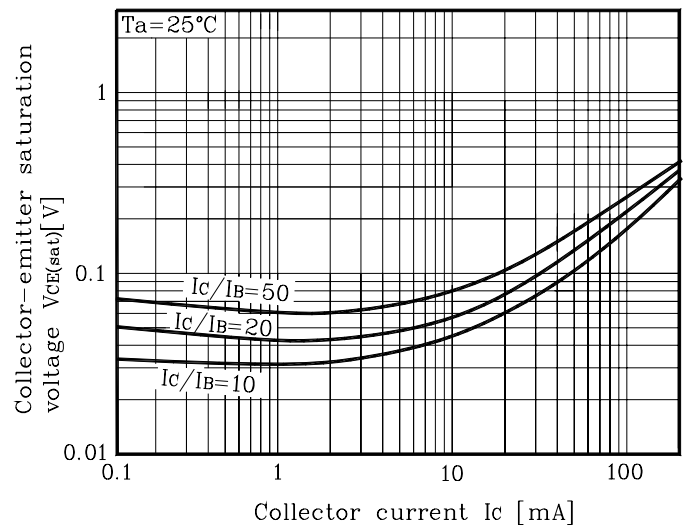

Fig. 4  $V_{CE(sat)} - I_C$



[Tr2]

Fig. 1  $I_C - V_{BE}$

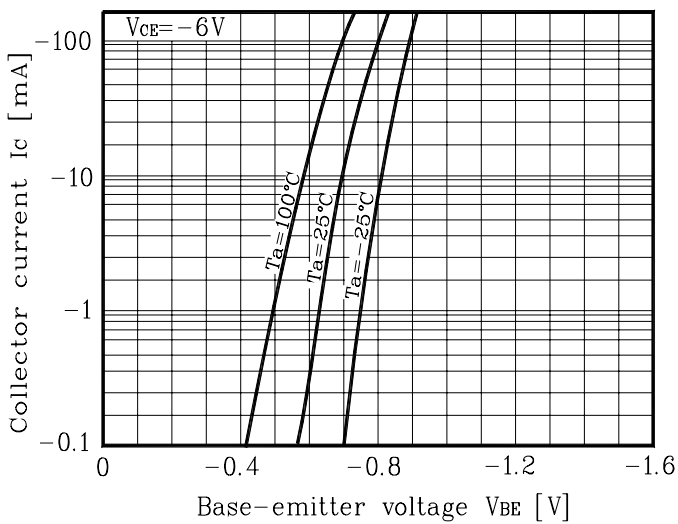
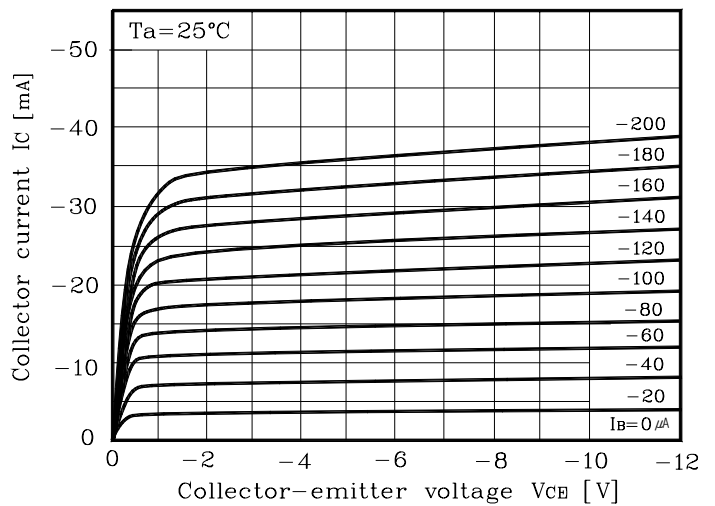

Fig. 2  $I_C - V_{CE}$



Electrical Characteristic Curves

Fig. 3  $h_{FE}-I_C$

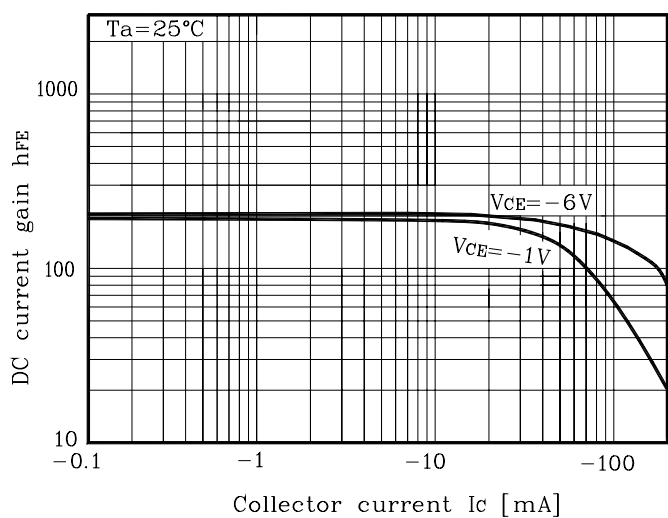
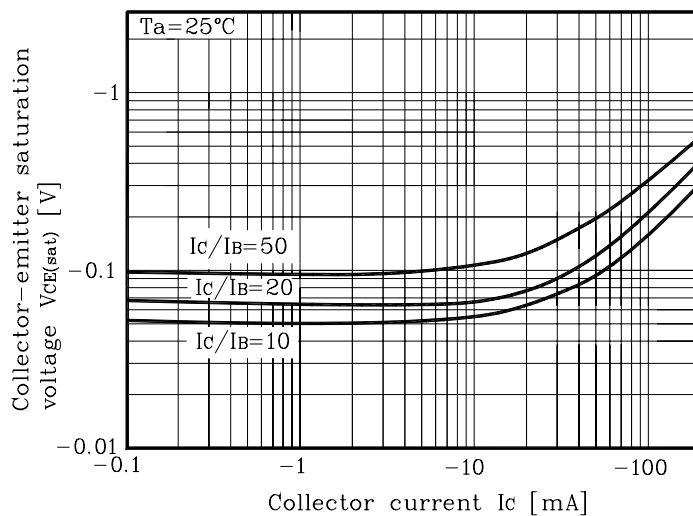
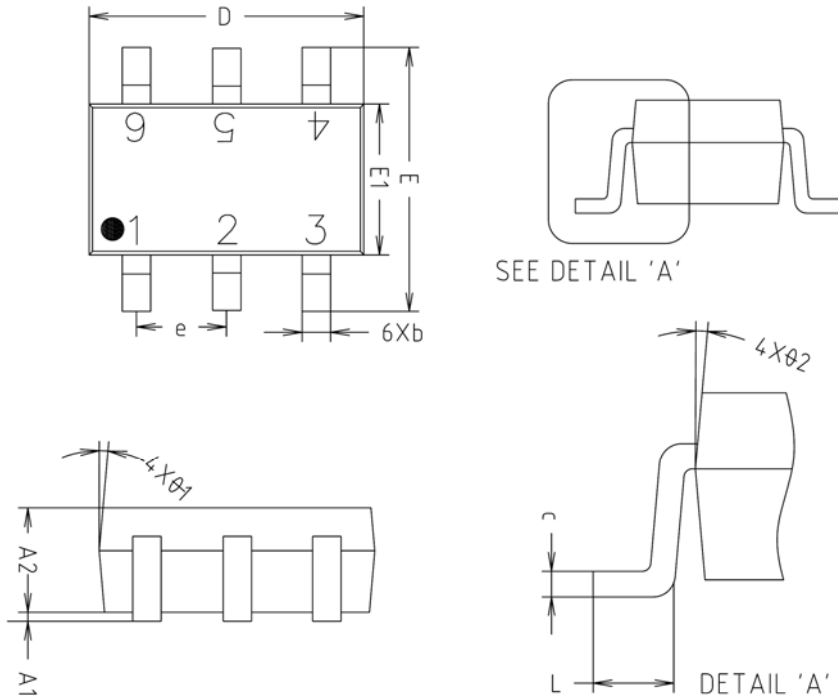

Fig. 4  $V_{CE(sat)}-I_C$



SOT-26 Outline Dimension(mm)



| SYMBOL | MILLIMETERS(mm) |         |         | NOTE |
|--------|-----------------|---------|---------|------|
|        | MINIMUM         | NOMINAL | MAXIMUM |      |
| A1     | 0.000           | 0.050   | 0.100   |      |
| A2     | 1.000           | 1.100   | 1.200   |      |
| b      | -               | 0.400   | 0.450   |      |
| c      | 0.110           | 0.150   | 0.190   |      |
| D      | 2.800           | 2.900   | 3.000   |      |
| E      | 2.600           | 2.800   | 3.000   |      |
| E1     | 1.500           | 1.600   | 1.700   |      |
| e      | 0.930           | 0.950   | 0.970   |      |
| L      | 0.400           | -       | -       |      |
| Ø1     | 5° REF          |         |         |      |
| Ø2     | 5° REF          |         |         |      |

※ Recommend PCB solder land [Unit: mm]

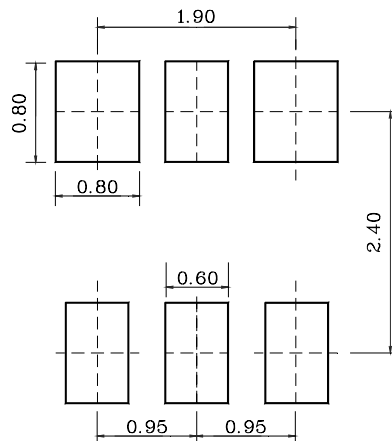

**The AUK Corp. products are intended for the use as components in general electronic equipment (Office and communication equipment, measuring equipment, home appliance, etc.).**

**Please make sure that you consult with us before you use these AUK Corp. products in equipments which require high quality and / or reliability, and in equipments which could have major impact to the welfare of human life(atomic energy control, airplane, spaceship, transportation, combustion control, all types of safety device, etc.). AUK Corp. cannot accept liability to any damage which may occur in case these AUK Corp. products were used in the mentioned equipments without prior consultation with AUK Corp..**

**Specifications mentioned in this publication are subject to change without notice.**