

**Description**

- General purpose application.
- Switching application.

**Features**

- Excellent  $h_{FE}$  linearity :  $h_{FE}(I_C=0.1mA) / h_{FE}(I_C=2mA) = 0.95(Typ.)$
- Low noise :  $NF = 10dB(Max.)$
- Complementary pair with STS9014

**Ordering Information**

Type NO.	Marking	Package Code
STS9015	STS9015	TO-92

**Outline Dimensions**

unit : mm

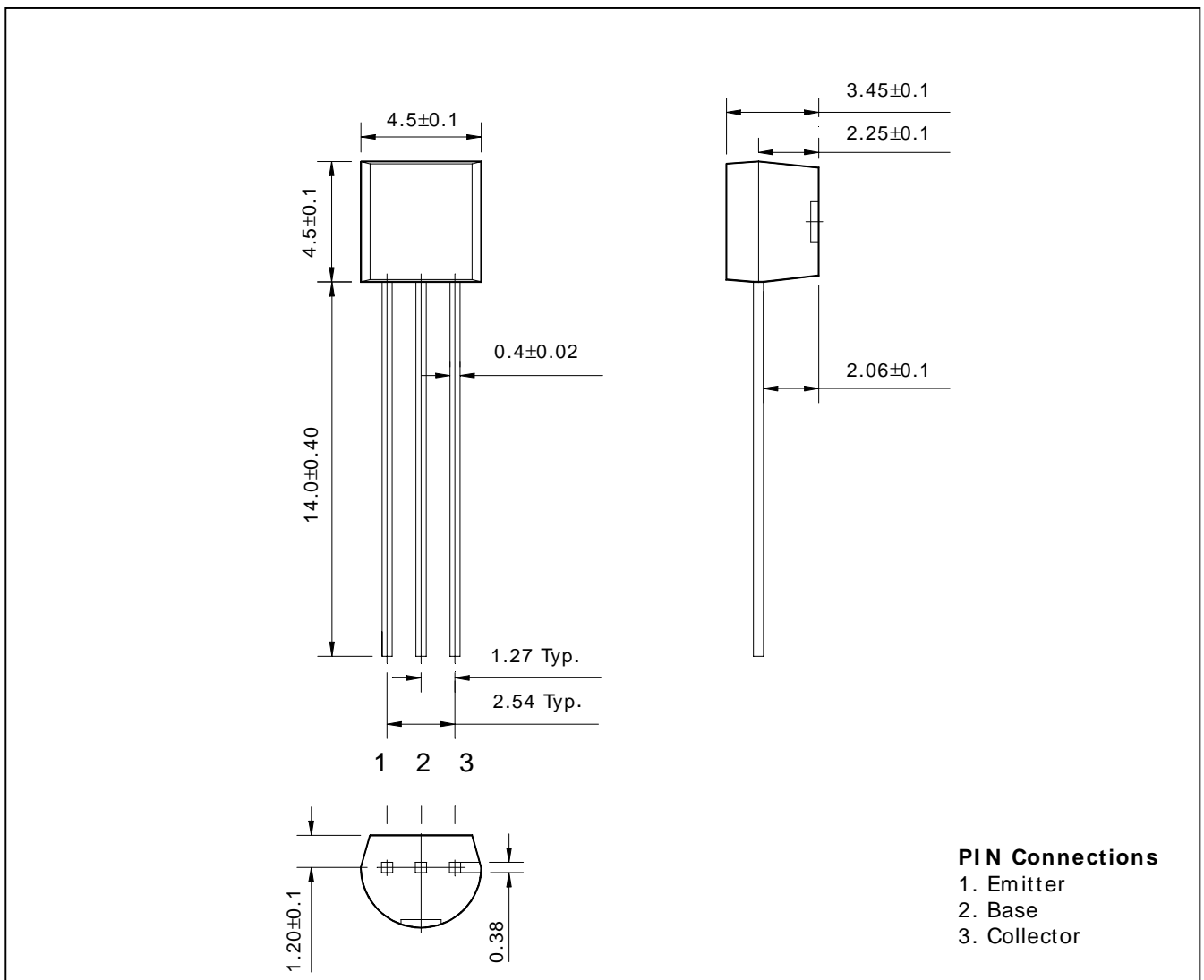

## Absolute maximum ratings

(Ta=25°C)

Characteristic	Symbol	Ratings	Unit
Collector-Base voltage	$V_{CBO}$	-50	V
Collector-Emitter voltage	$V_{CEO}$	-50	V
Emitter-Base voltage	$V_{EBO}$	-5	V
Collector current	$I_C$	-150	mA
Emitter current	$I_E$	150	mA
Collector dissipation	$P_C$	625	mW
Junction temperature	$T_j$	150	°C
Storage temperature	$T_{stg}$	-55~150	°C

## Electrical Characteristics

(Ta=25°C)

Characteristic	Symbol	Test Condition	Min.	Typ.	Max.	Unit
Collector cut-off current	$I_{CBO}$	$V_{CB} = -50V, I_E = 0$	-	-	-50	nA
Emitter cut-off current	$I_{EBO}$	$V_{EB} = -5V, I_C = 0$	-	-	-100	nA
DC current gain	$h_{FE}$	$V_{CE} = -5V, I_C = -1mA$	100	-	1000	-
Collector-Emitter saturation voltage	$V_{CE(sat)}$	$I_C = -100mA, I_B = -10mA$	-	-0.1	-0.3	V
Transition frequency	$f_T$	$V_{CE} = -10V, I_C = -1mA$	60	-	-	MHz
Collector output capacitance	$C_{ob}$	$V_{CB} = -10V, I_E = 0, f = 1MHz$	-	4	7	pF
Noise figure	NF	$V_{CE} = -6V, I_C = -0.1mA$ $f = 1KHz, R_g = 10K\Omega$	-	-	10	dB

\*:  $h_{FE}$  rank / B : 100~300, C : 200~600, D : 400~1000.

Electrical Characteristic Curves

Fig. 1  $P_C$ - $T_a$

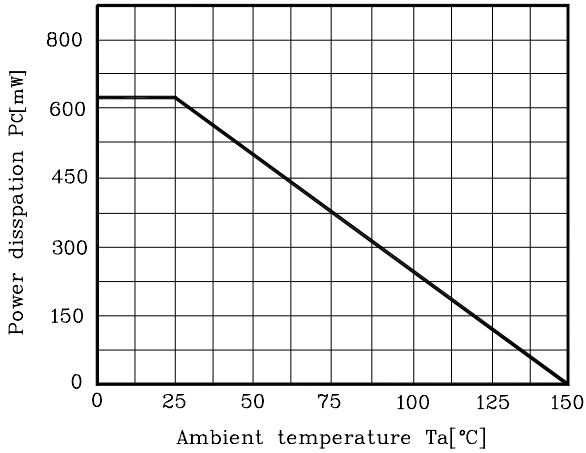

Fig. 2  $I_C$ - $V_{BE}$

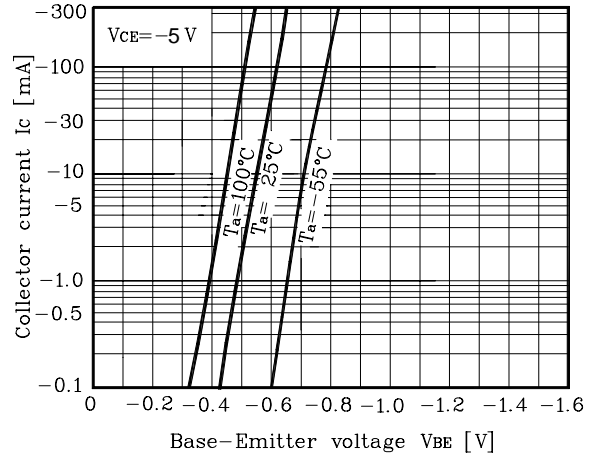

Fig. 3  $I_C$ - $V_{CE}$

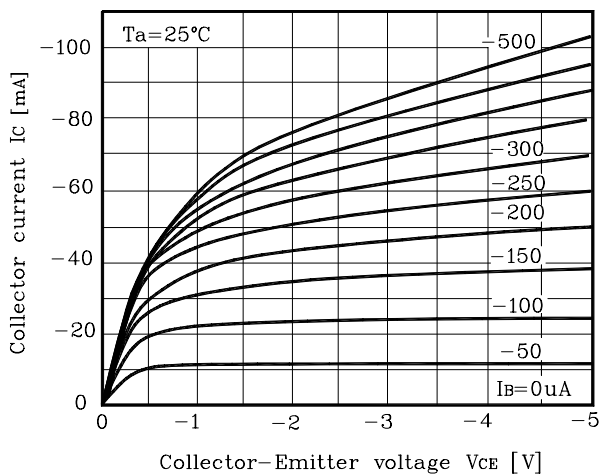

Fig. 4  $h_{FE}$ - $I_C$

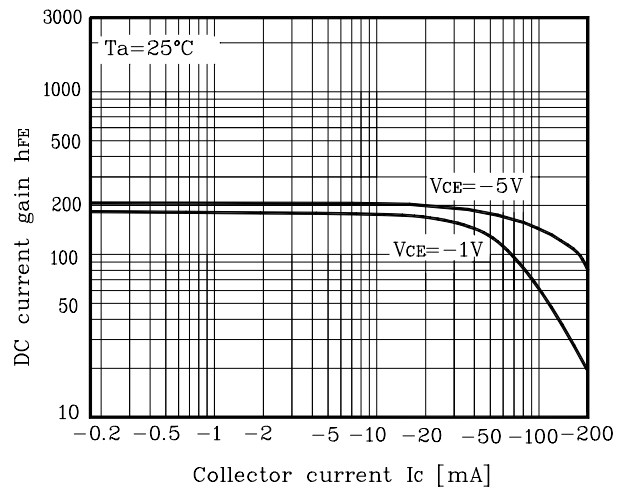

Fig. 5  $V_{CE(sat)}$ - $I_C$

