

Description

- Medium power amplifier

Features

- Large collector current : $I_{CMax} = -500mA$
- Suitable for low-Voltage operation because of its low saturation voltage
- Complementary pair with STS5342

Ordering Information

Type NO.	Marking	Package Code
STS1979	STS1979	TO-92

Outline Dimensions

unit : mm

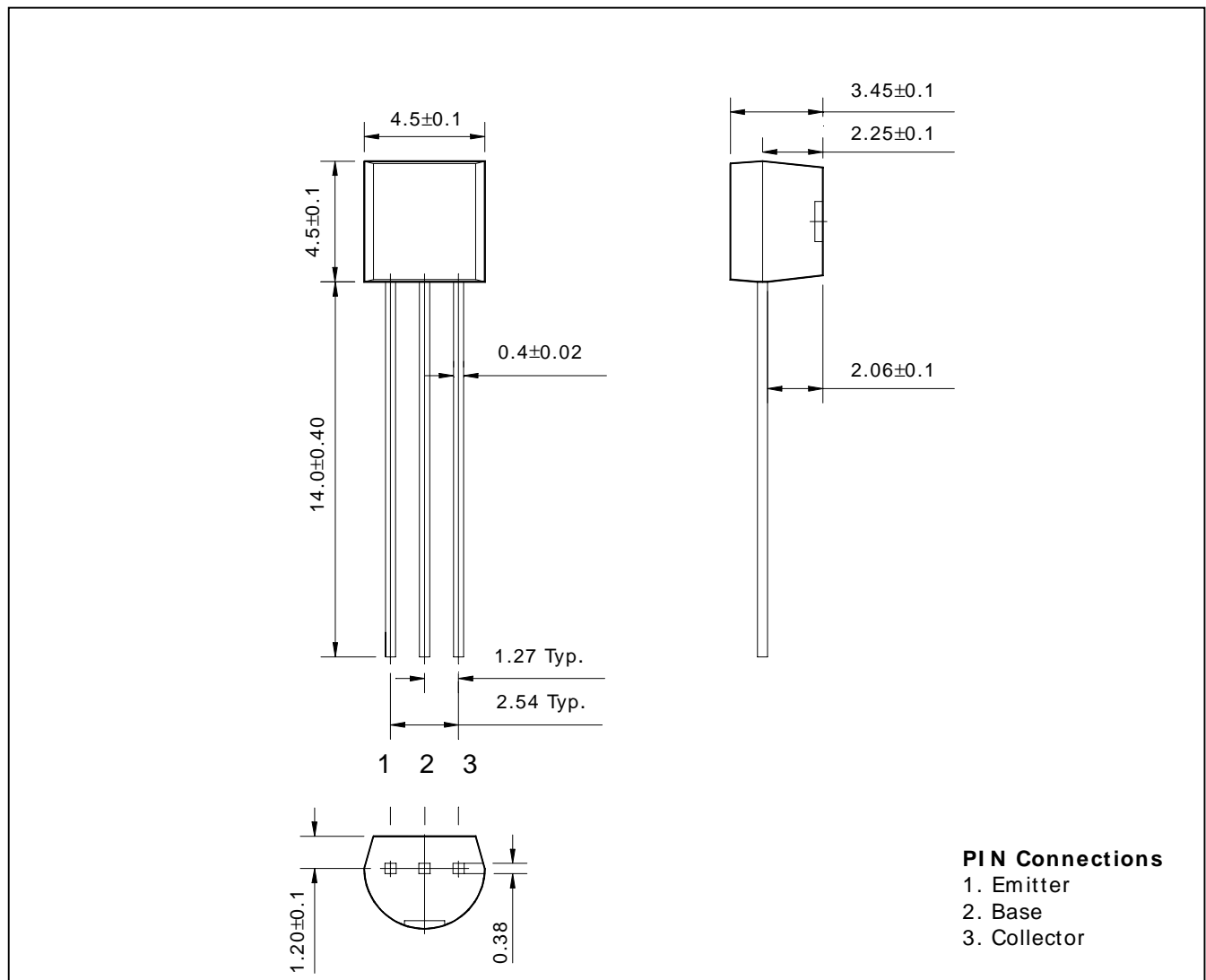

Absolute maximum ratings

(Ta=25°C)

Characteristic	Symbol	Ratings	Unit
Collector-Base voltage	V_{CBO}	-40	V
Collector-Emitter voltage	V_{CEO}	-32	V
Emitter-Base voltage	V_{EBO}	-5	V
Collector current	I_C	-500	mA
Collector dissipation	P_C	625	mW
Junction temperature	T_j	150	°C
Storage temperature	T_{stg}	-55~150	°C

Electrical Characteristics

(Ta=25°C)

Characteristic	Symbol	Test Condition	Min.	Typ.	Max.	Unit
Collector-Base breakdown voltage	BV_{CBO}	$I_C = -100\mu A, I_E = 0$	-40	-	-	V
Collector-Emitter breakdown voltage	BV_{CEO}	$I_C = -10mA, I_B = 0$	-32	-	-	V
Emitter-Base breakdown voltage	BV_{EBO}	$I_E = -10\mu A, I_C = 0$	-5	-	-	V
Collector cut-off current	I_{CBO}	$V_{CB} = -40V, I_E = 0$	-	-	-0.1	μA
Emitter cut-off current	I_{EBO}	$V_{EB} = -5V, I_C = 0$	-	-	-0.1	μA
DC current gain	h_{FE}	$V_{CE} = -1V, I_C = -100mA$	120	-	240	-
Collector-Emitter saturation voltage	$V_{CE(sat)}$	$I_C = -100mA, I_B = -10mA$	-	-	-0.25	V
Transistor frequency	f_T	$V_{CE} = -6V, I_C = -20mA$	-	200	-	MHz
Collector output capacitance	C_{ob}	$V_{CB} = -6V, I_E = 0, f = 1MHz$	-	7.5	-	pF

Electrical Characteristic Curves

Fig. 1 $P_C - T_a$

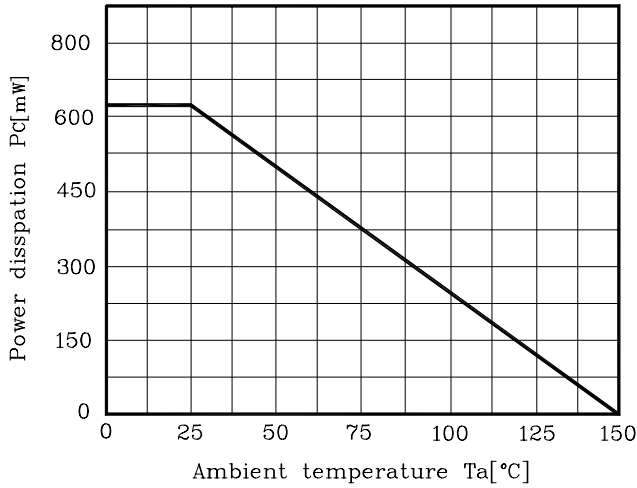

Fig. 2 $I_C - V_{BE}$

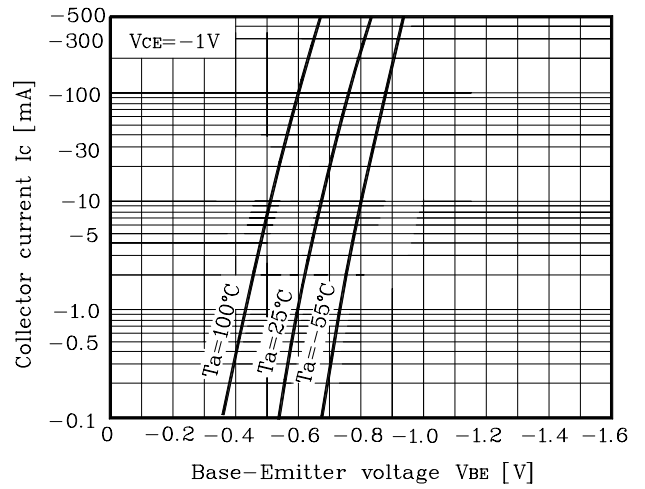

Fig. 3 $I_C - V_{CE}$

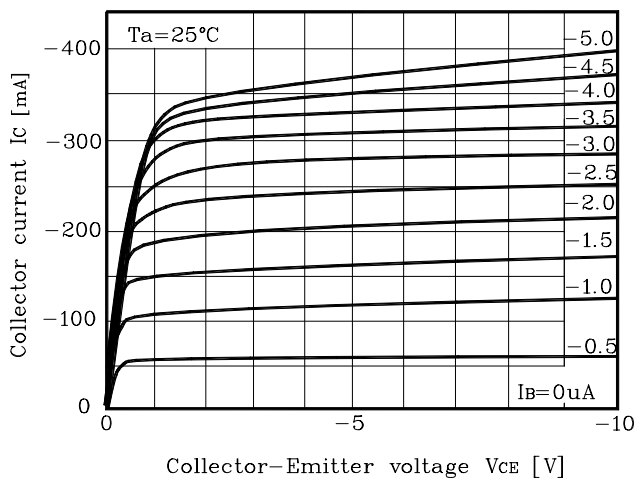

Fig. 4 $V_{CE(sat)} - I_C$

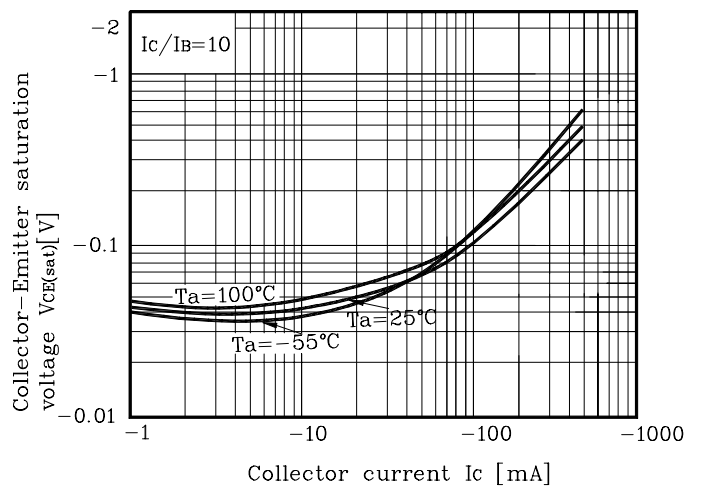

Fig. 5 $h_{FE} - I_C$

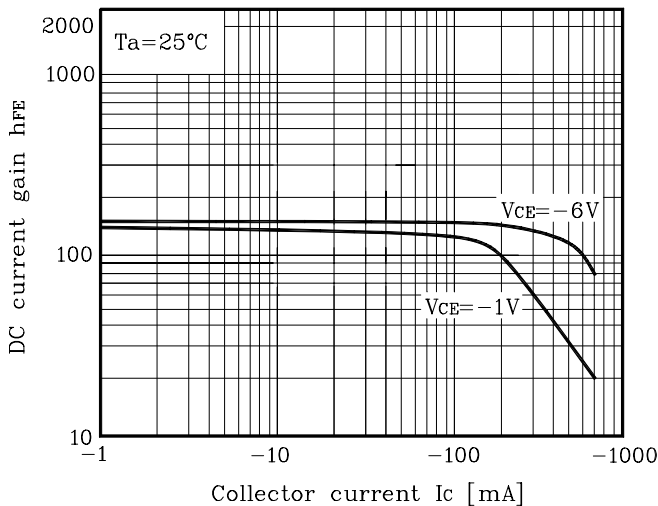

Fig. 6 $h_{FE} - I_C$

