

Descriptions

- High current application
- Radio in class B push-pull operation

Feature

- Complementary pair with STC8050SF

Ordering Information

Type NO.	Marking	Package Code				
STA8550SF	8B <table border="1" style="display: inline-table; vertical-align: middle;"><tr><td>□</td><td>□</td></tr><tr><td>①</td><td>② ③</td></tr></table>	□	□	①	② ③	SOT-23F
□	□					
①	② ③					

① Device Code ② hFE Rank ③ Year & Week Code

PIN Connection

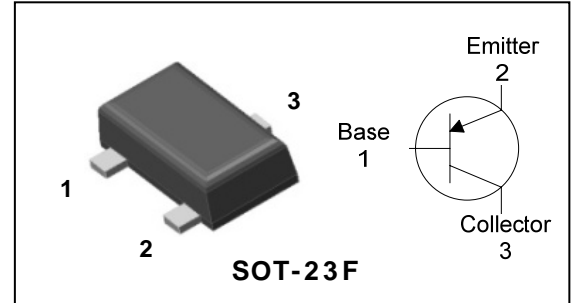

Absolute Maximum Ratings

(Ta=25°C)

Characteristic	Symbol	Rating	Unit
Collector-base voltage	V_{CBO}	-30	V
Collector-emitter voltage	V_{CEO}	-25	V
Emitter-base voltage	V_{EBO}	-6	V
Collector current	I_C	-800	mA
Collector power dissipation	P_C^*	350	mW
Junction temperature	T_J	150	°C
Storage temperature range	T_{stg}	-55 ~ 150	°C

* : Package mounted on 99.5% Alumina 10×8×0.6mm

Electrical Characteristics

(Ta=25°C)

Characteristic	Symbol	Test Condition	Min.	Typ.	Max.	Unit
Collector-emitter breakdown voltage	BV_{CEO}	$I_C = -1\text{mA}, I_B = 0$	-25	-	-	V
Collector cut-off current	I_{CBO}	$V_{CB} = -30\text{V}, I_E = 0$	-	-	-50	nA
Emitter cut-off current	I_{EBO}	$V_{EB} = -6\text{V}, I_C = 0$	-	-	-50	nA
DC current gain	h_{FE}^*	$V_{CE} = -1\text{V}, I_C = -50\text{mA}$	85	-	300	-
Collector-emitter saturation voltage	$V_{CE(sat)}$	$I_C = -500\text{mA}, I_B = -50\text{mA}$	-	-	-0.5	V
Base-emitter voltage	V_{BE}	$V_{CE} = -1\text{V}, I_C = -500\text{mA}$	-	-0.85	-1.2	V
Transition frequency	f_T	$V_{CE} = -5\text{V}, I_C = -10\text{mA}$	-	200	-	MHz
Collector output capacitance	C_{ob}	$V_{CB} = -10\text{V}, I_E = 0, f = 1\text{MHz}$	-	19	-	pF

* : h_{FE} Rank / B : 85~160, C : 120~200, D : 160~300

Electrical Characteristic Curves

Fig. 1 $P_c - T_a$

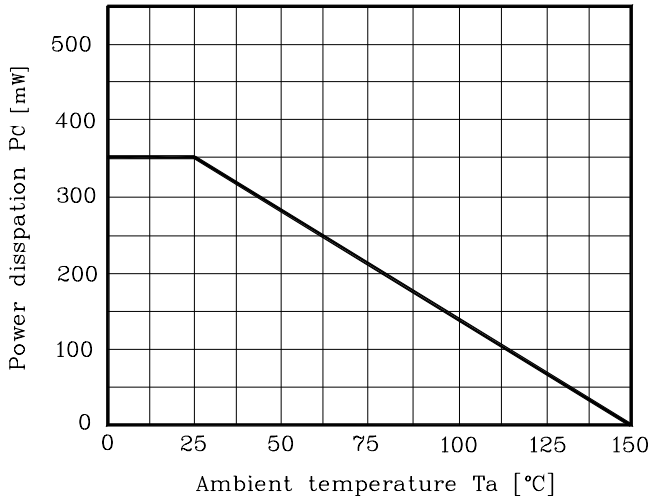

Fig. 2 $I_c - V_{BE}$

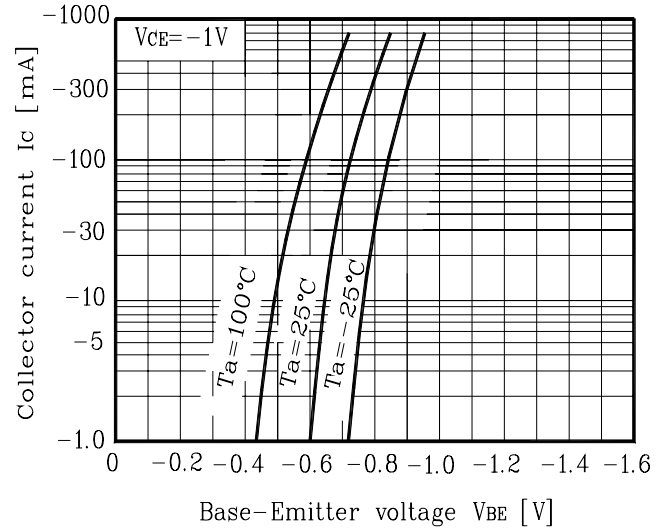

Fig. 3 $I_c - V_{CE}$

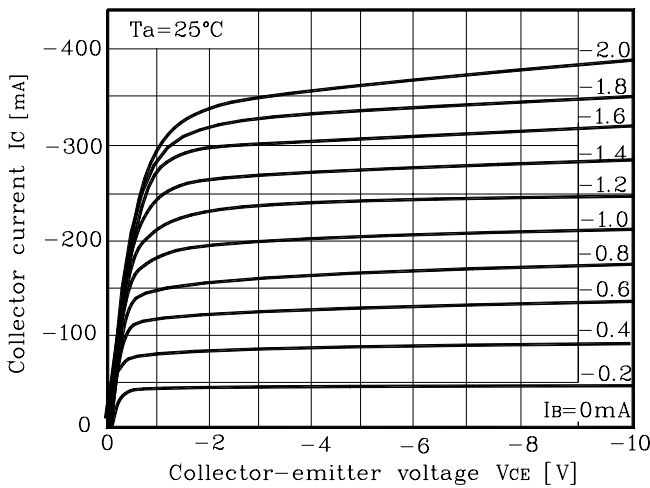

Fig. 4 $V_{CE(SAT)} - I_c$

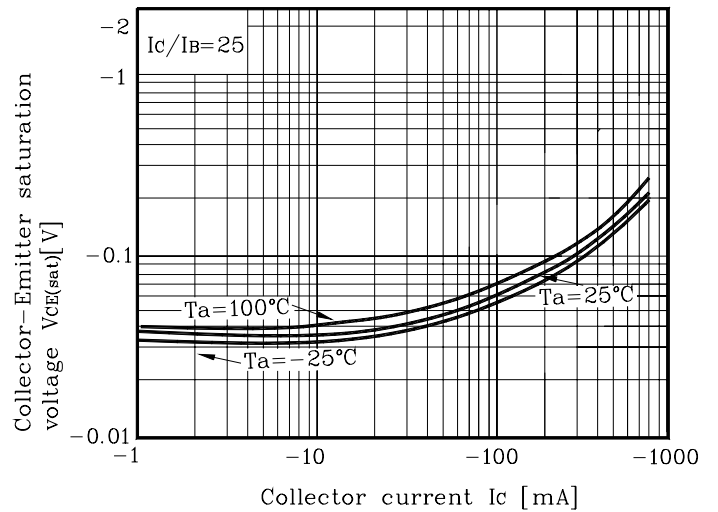

Fig. 5 $h_{FE} - I_c$

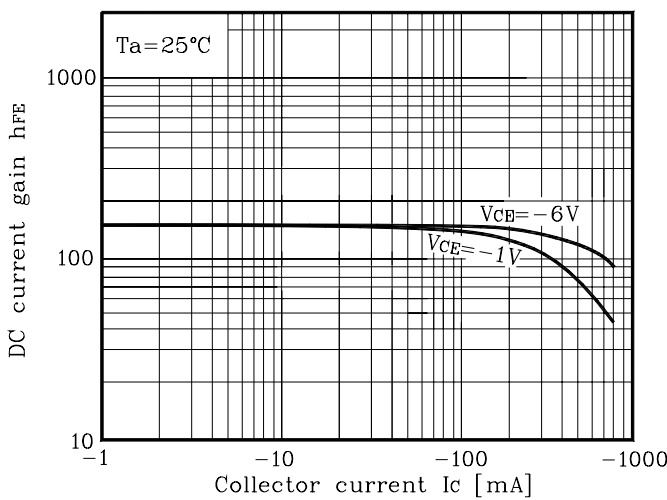
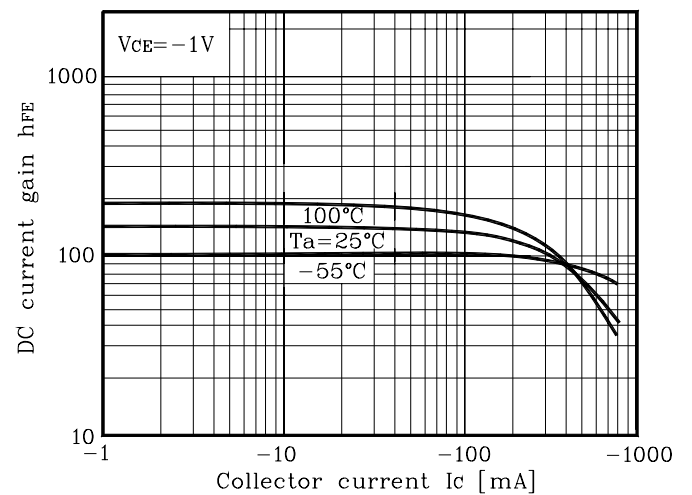
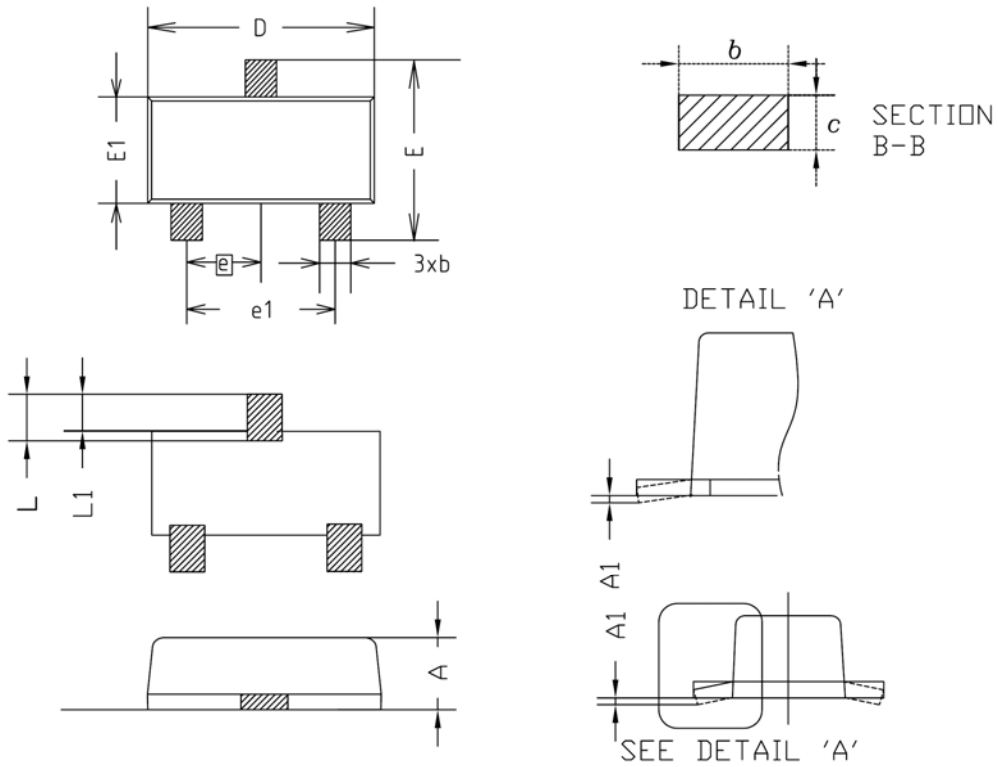

Fig. 6 $h_{FE} - I_c$



Outline Dimension



SYMBOL	MILLIMETER(mm)			NOTE
	MINIMUM	NOMINAL	MAXIMUM	
A	0.80	0.90	1.00	
A1	0.00	-	0.10	
b	0.35	0.40	0.45	
c	0.10	0.15	0.20	
D	2.80	2.90	3.00	
E	2.30	2.40	2.50	
E1	1.50	1.60	1.70	
e	0.95BSC			
e1	1.80	1.90	2.00	
L	0.48	0.58	0.68	
L1	0.30	-	0.50	

※Recommend PCB solder land [Unit: mm]

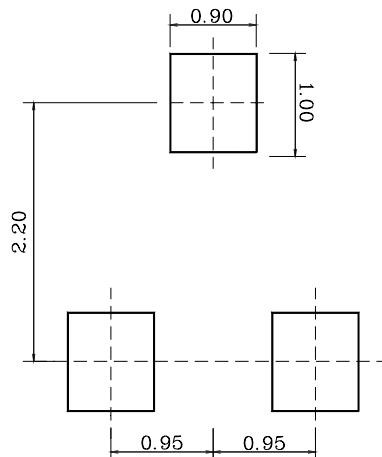

The AUK Corp. products are intended for the use as components in general electronic equipment (Office and communication equipment, measuring equipment, home appliance, etc.).

Please make sure that you consult with us before you use these AUK Corp. products in equipments which require high quality and / or reliability, and in equipments which could have major impact to the welfare of human life(atomic energy control, airplane, spaceship, transportation, combustion control, all types of safety device, etc.). AUK Corp. cannot accept liability to any damage which may occur in case these AUK Corp. products were used in the mentioned equipments without prior consultation with AUK Corp..

Specifications mentioned in this publication are subject to change without notice.