

◆ Description

The SN7500 is a monolithic integrated circuit which includes all the necessary building blocks for the design of pulse width modulate(PWM) switching power supplies, including push-pull, bridge and series configuration. The precision of voltage reference is improved up to $\pm 1\%/\pm 2\%$ through trimming and this provides a better output voltage regulation. The device can operate at switching frequencies between 1KHz and 300KHz and output voltage up to 36V.

The SN7500 is specified over an operating temperature range of $-40^{\circ}\text{C} \sim +85^{\circ}\text{C}$.

◆ Features

- Internal Regulator Provides a Stable 5V Reference Supply Trimmed to $\pm 1\%$ or $\pm 2\%$ Accuracy
- Uncommitted output transistors capable of 200mA source or sink
- Internal protection from double pulsing of out-puts with narrow pulse widths or with supply voltages below specified limits
- Easily synchronized to other circuits
- Dead time control comparator
- Output control selects single-ended or push-pull operation
- Operating temperature range : $-40^{\circ}\text{C} \sim +85^{\circ}\text{C}$
- Halogen-Free Package is Available
- High Level ESD Protection : 400V(MM), 4KV(HBM)

◆ Package Type

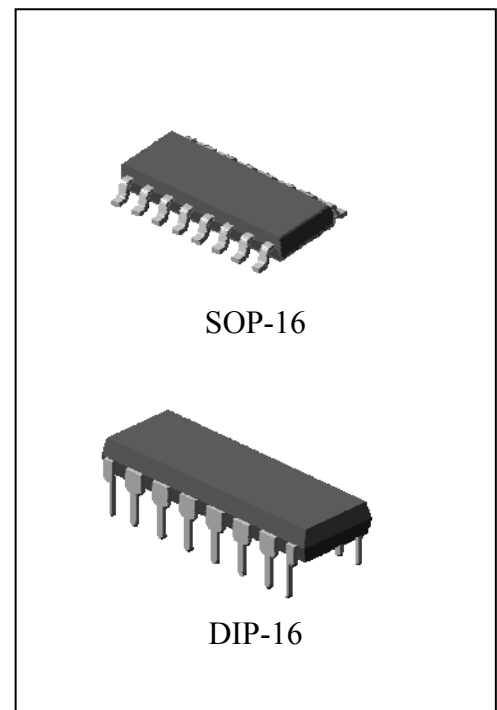

◆ Application

- Charger
- SMPS
- Back Light Inverter

◆ Ordering Information

Device Name	PKG Type	Marking
SN7500x	SOP-16	SN7500---(1) YWW---(2)
SN7500xP	DIP-16	SN7500---(1) YWW---(2)

(a) Rank X : B = Vref 2% / C = Vref 1%

(b) Marking Information : (1) Device Code, (2) Year & Week Code

◆ Pin Configuration (Top View)

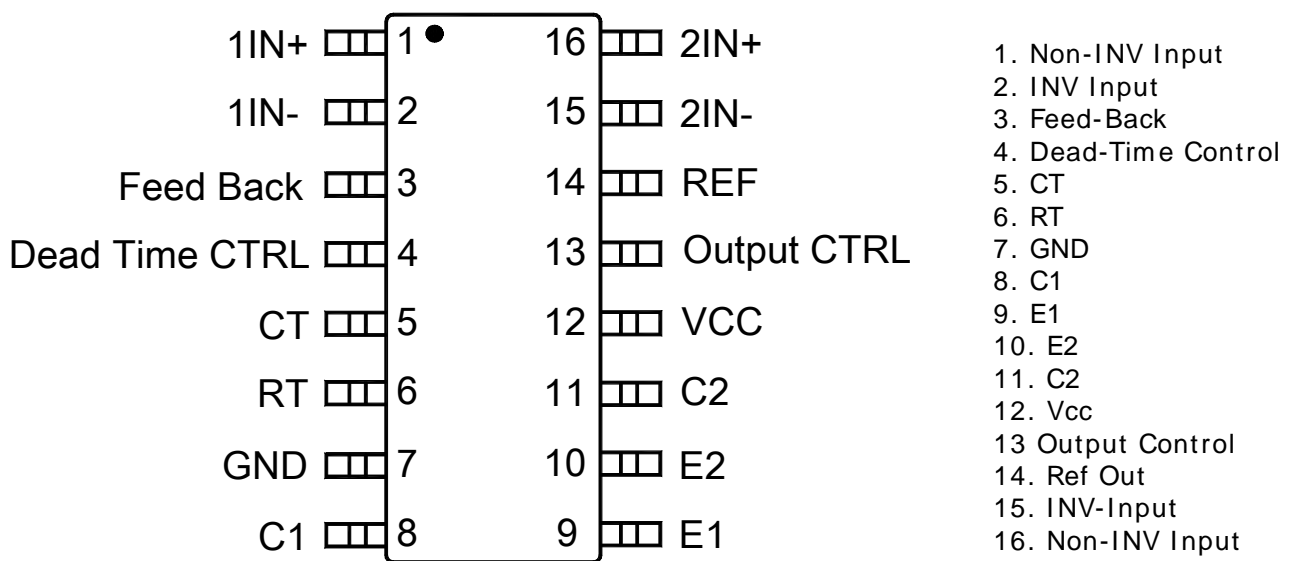

◆ Block Diagram

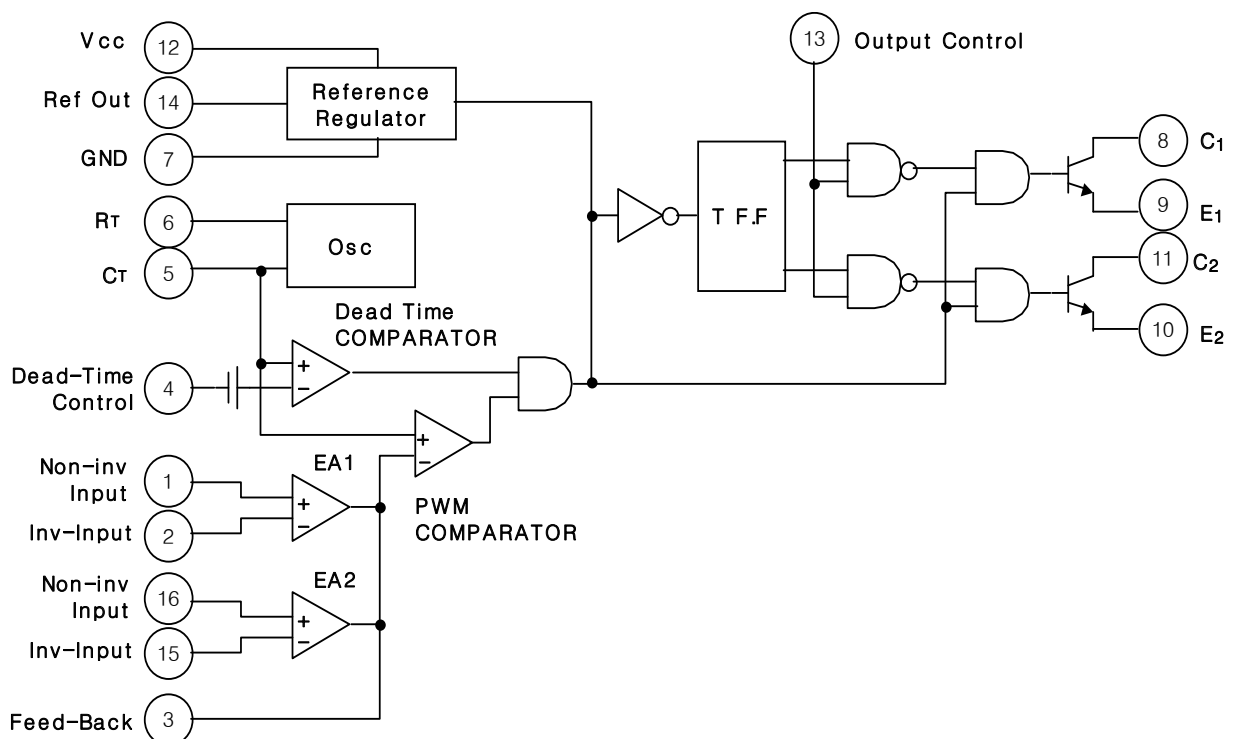

◆ Absolute Maximum Ratings

Ta=25°C

Characteristic	Symbol	Ratings	Unit	
Supply Voltage	V _{CC}	40	V	
Collector Supply Voltage	V _C	40	V	
Output Current	I _o	250	mA	
Amplifier Input Voltage	V _{in}	V _{CC} +0.3	V	
Power Dissipation	SOP-16	P _D	1500	mW
	DIP-16	P _D	1700	mW
Operating Temperature	T _{opr}	-40 ~ +85	°C	
Storage Temperature	T _{stg}	-55 ~ +150	°C	

◆ Recommended Operating Condition

Characteristic	Symbol	Min.	Typ.	Max.	Unit
Supply Voltage	V _{CC}	7	15	36	V
Collector Output Voltage	V _{C1} , V _{C2}	-	30	36	V
Collector Output Current	I _{C1} , I _{C2}	-	-	200	mA
Amplifier Input Voltage	V _{in}	-0.3	-	V _{CC} -2.0	V
Current Into Feedback Terminal	I _{FB}	-	-	0.3	mA
Reference Output Current	I _{REF}	-	-	10	mA
Timing Resistor	R _T	1.8	30	500	kΩ
Timing Capacitor	C _T	0.0047	0.001	10	uF
Oscillator Frequency	f _{OSC}	1	40	300	KHz
PWM Input Voltage (Pin 3, 4, 13)	-	0.3	-	5.3	V

Reference Section

Characteristic	Symbol	Test Condition	Min.	Typ.	Max.	Unit	
Output Reference Voltage	V _{ref}	I _{ref} = 1.0mA, Ta= 25°C	SN7500B	4.90	5.00	5.10	V
		I _{ref} = 1.0mA, Ta= -25~ 85°C		4.80	5.00	5.20	
		I _{ref} = 1.0mA, Ta= 25°C	* SN7500C	4.95	5.00	5.05	
		I _{ref} = 1.0mA, Ta= -25~ 85°C		4.90	5.00	5.10	
Line Regulation	V _{LINE}	7V < V _{CC} < 20V	-	2	25	mV	
Load Regulation	V _{LOAD}	1mA < I _{REF} < 10mA	-	1	15	mV	
Short Circuit Current	I _{sc}	V _{ref} =0V	10	35	50	mA	

[* : Under Development] SN7500B(Tol. 2%), SN7500C(Tol. 1%)

Oscillator Section

Characteristic	Symbol	Test Condition	Min.	Typ.	Max.	Unit
Oscillation Frequency	f _{OSC}	C _t = 0.001 μF, R _t = 30 kΩ	-	40	-	KHz
		C _t = 0.01 μF, R _t = 12 kΩ, Ta= 25°C	9.2	10	10.8	
		C _t = 0.01 μF, R _t = 12 kΩ, Ta= 25~ 85°C	9	-	12	
Oscillation Frequency Change With Temperature	Δf _{sod} /ΔT	C _t = 0.01 μF, R _t = 12 kΩ, Ta= 25~ 85°C	-	-	2	%

Dead Time Control Section

Characteristic		Symbol	Test Condition	Min.	Typ.	Max.	Unit
Input Bias Current (Pin4)		$I_{IB(DT)}$	$V_{CC} = 15V, 0V < V_4 < 5.25V$	-	-2	-10	μA
Max. Duty cycle		$D_{(Max)}$	$V_{CC} = 15V, Pin4 = 0V,$ $Output\ Control\ Pin = V_{ref}$	45	-	-	%
Input Threshold Voltage	Zero Duty	V_{TH}	-	-	2.8	3.3	V
	Max Duty			0	-	-	

Error Amplifier Section

Characteristic		Symbol	Test Condition	Min.	Typ.	Max.	Unit
Input Offset Voltage		V_{IOS}	$V_3 = 2.5V$	-	2	10	mV
Input Offset Current		I_{IOS}	$V_3 = 2.5V$	-	25	250	nA
Input Bias Current		I_{IB}	$V_3 = 2.5V$	-	0.2	1	μA
Common Mode Input voltage Range		V_{ICR}	$7V \leq V_{CC} \leq 20V$	-0.3	-	$V_{CC}-2$	V
Large Signal Open Loop Voltage Range		G_{VO}	$0.5V \leq V_3 \leq 3.5V$	60	74	-	dB
Unity Gain Band width		GBW	-	-	650	-	KHz
Open Loop Voltage Gain		GVO	$0.5V \leq V_o \leq 3.5V$	70	95	-	dB
Output Sink Current		I_{sink}	$-15mV \leq V_{id} \leq -5V, V_3=0.7V$	-0.3	-0.7	-	mA
Common Mode Rejection Ratio		CMRR	-	65	80	-	dB
Output Source Current		I_{source}	$15mV \leq V_{id} \leq 5V, V_3=3.5V$	2	-	-	mA

PWM Comparator Section (Pin3)

Characteristic		Symbol	Test Condition	Min.	Typ.	Max.	Unit
Input Threshold Voltage		V_{ITH}	Zero duty cycle	-	4	4.5	V
Input Sink Current		I_{o^-}	$V_3=0.7V$	-0.3	-0.7	-	mA

Output Section

Characteristic		Symbol	Test Condition	Min.	Typ.	Max.	Unit
Output Saturation Voltage	Common-Emitter	$V_{CE(SAT)}$	$V_E = 0V, I_C = 200mA$	-	1.1	1.3	V
	Emitter-Follower		$V_{CC} = 15V, I_E = -200mA$	-	1.5	2.5	
Collector off-state Current		$I_{C(off)}$	$V_{CC} = V_{CE} = 20V, V_E = 0$	-	2	100	μA
Emitter off-state Current		$I_{E(off)}$	$V_{CC} = V_C = 20V, V_E = 0$	-	-	-100	
Total Device							
Standby power Supply Current		I_{CC}	Pin6= V_{ref} , $V_{CC} = 15V$	-	3.5	10	mA

Output Switching Characteristic

Characteristic		Symbol	Test Condition	Min.	Typ.	Max.	Unit
Rise Time	Common Emitter	t_r	-	-	100	200	ns
	Emitter Follower			-	100	200	
Fall Time	Common Emitter	t_f	-	-	25	100	
	Emitter Follower			-	25	100	

INFORMATION

The basic oscillator (switching) frequency is controlled by an external resistor (R_T) and capacitor (C_T). The relationship between the values of R_T, C_T and frequency is shown in.

The level of the sawtooth wave form is compared with an error voltage by the pulse width modulated comparator. The output of the PWM Comparator directs the pulse steering flip flop and the output control logic.

The error voltage is generated by the error amplifier. The error amplifier boosts the voltage difference between the output and the 5V internal reference. See Figure 7 for error amp sensing techniques. The second error amp is typically used to implement current limiting. The output control logic (Pin 13) selects either push-pull or single-ended operation of the output transistors (see Figure 6). The dead time control prevents on-state overlap of the output transistors as can be seen in Figure 5. The dead time is approximately 3 to 5% of the total period if the dead time control (pin 4) is grounded. This dead time can be increased by connecting the dead time control to a voltage up to 5 V. The frequency response of the error amps can be modified by using external resistors and capacitors. These components are typically connected between the compensation terminal (pin 3) and the inverting input of the error amps (pin 2 or pin 15). The switching frequency of two or more SJ7500 circuits can be synchronized. The timing capacitor, C_t is connected as shown in Figure 8. Charging current is provided by the master circuit. Discharging is through all the circuits slaved to the master. R_t is required only for the master circuit.

Operating Waveform

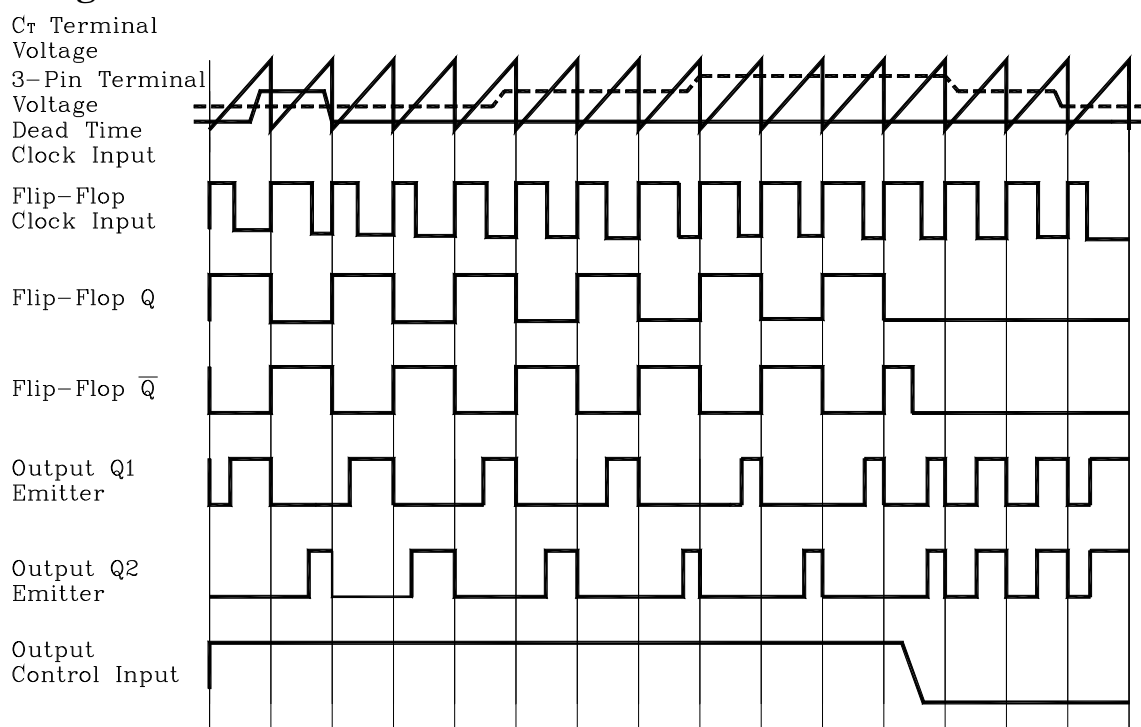

Test Circuit

Fig.1 Error Amplifier Test Circuit

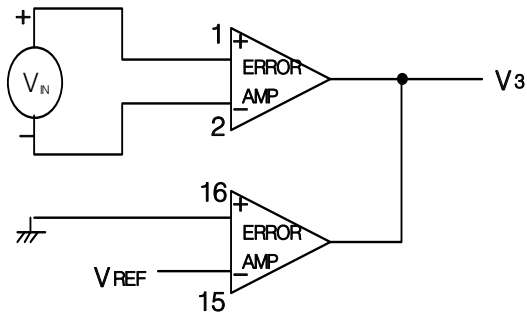

Fig.2 Current Limit sense Amplifier Test Circuit

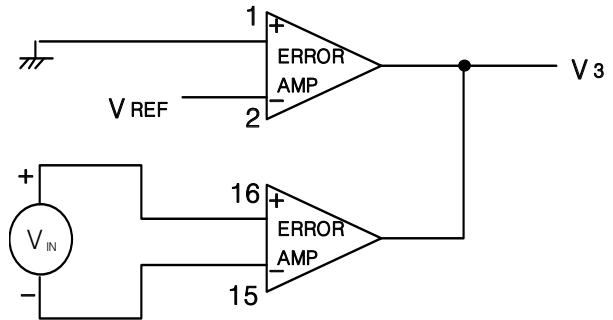

Fig. 3 Common-Emitter Configuration Test circuit and Waveform

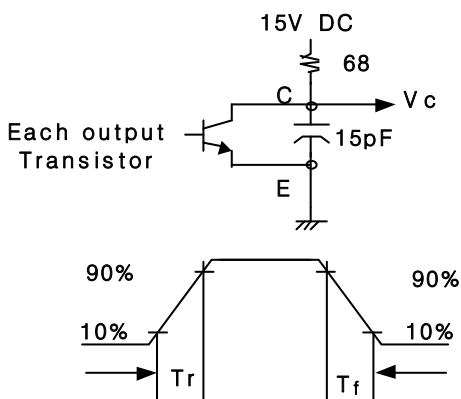

Fig. 5 Dead-Time and Feedback Control Test Circuit

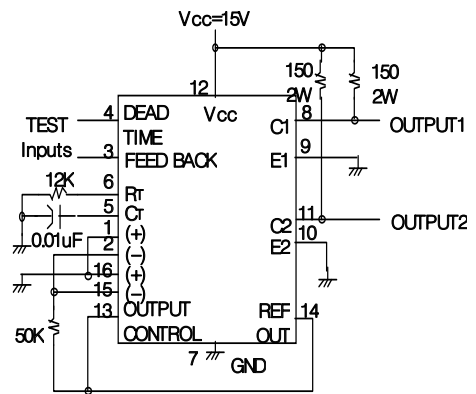

Fig. 4 Emitter-Follower Configuration Test circuit and waveform Voltage waveform



APPLICATION CIRCUIT

Fig. 6 Output Connections for Single-Ended and Push-Pull Configurations

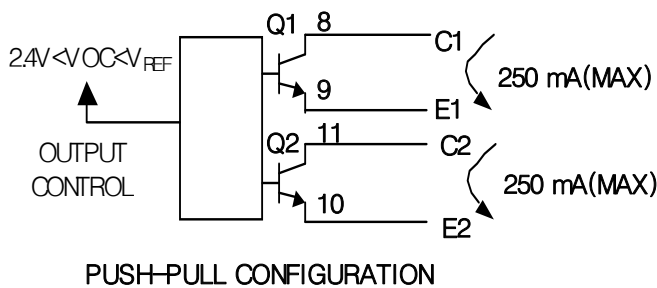
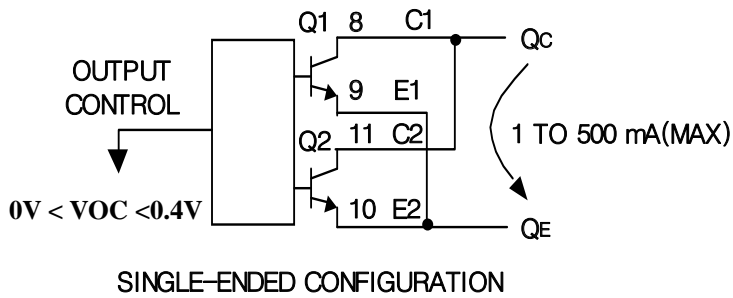

Fig. 7 Error Amplifier Sensing Techniques

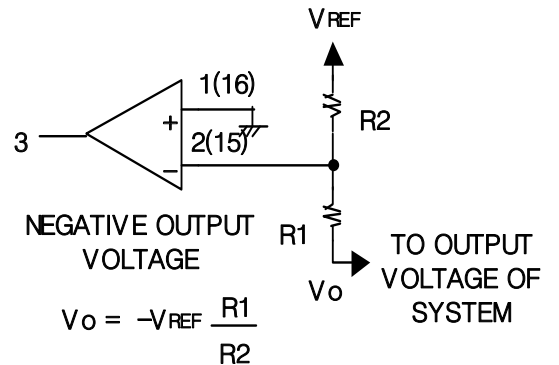
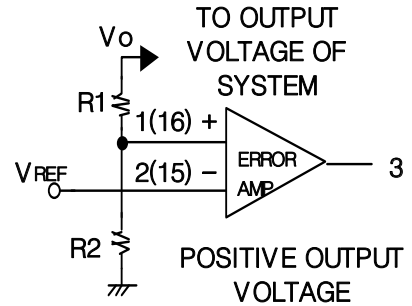

Fig. 8 Slaving Two or More Control Circuits

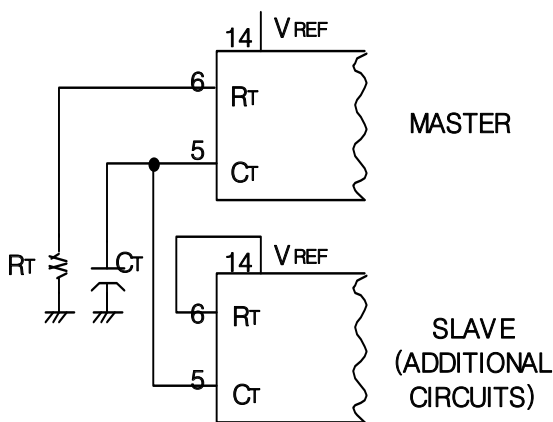
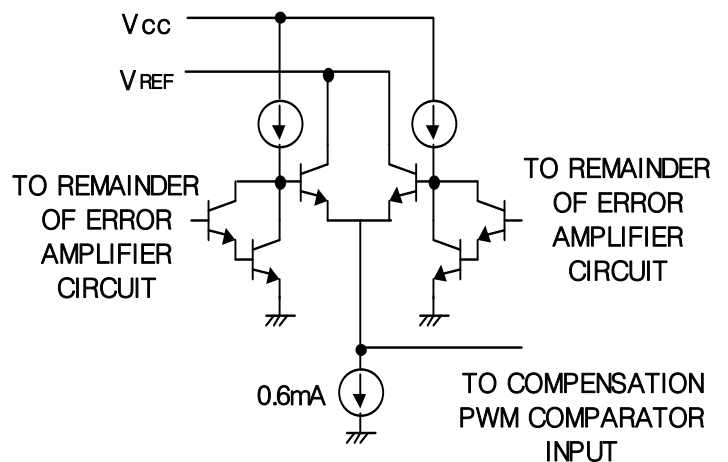

Fig. 9 Error Amplifier and Current Limit Sense Amplifier Output Circuits



◆ Electrical Characteristic Curves

Fig.10 Oscillator Frequency vs Timing Resistance

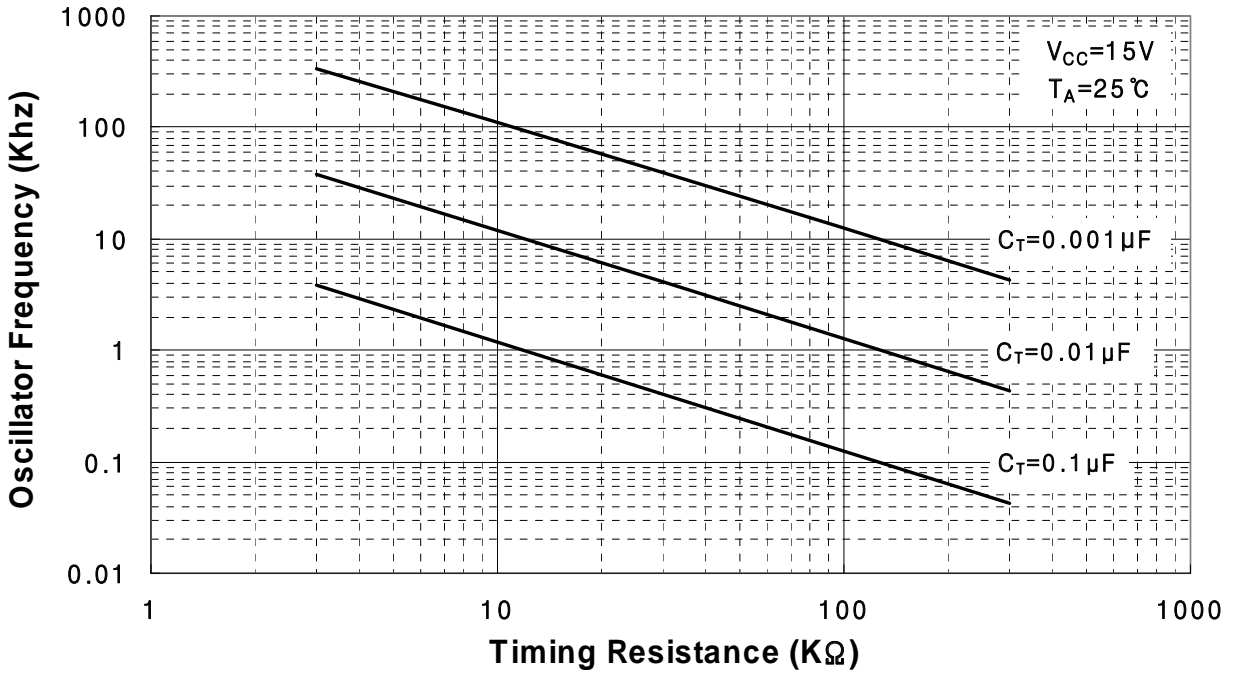
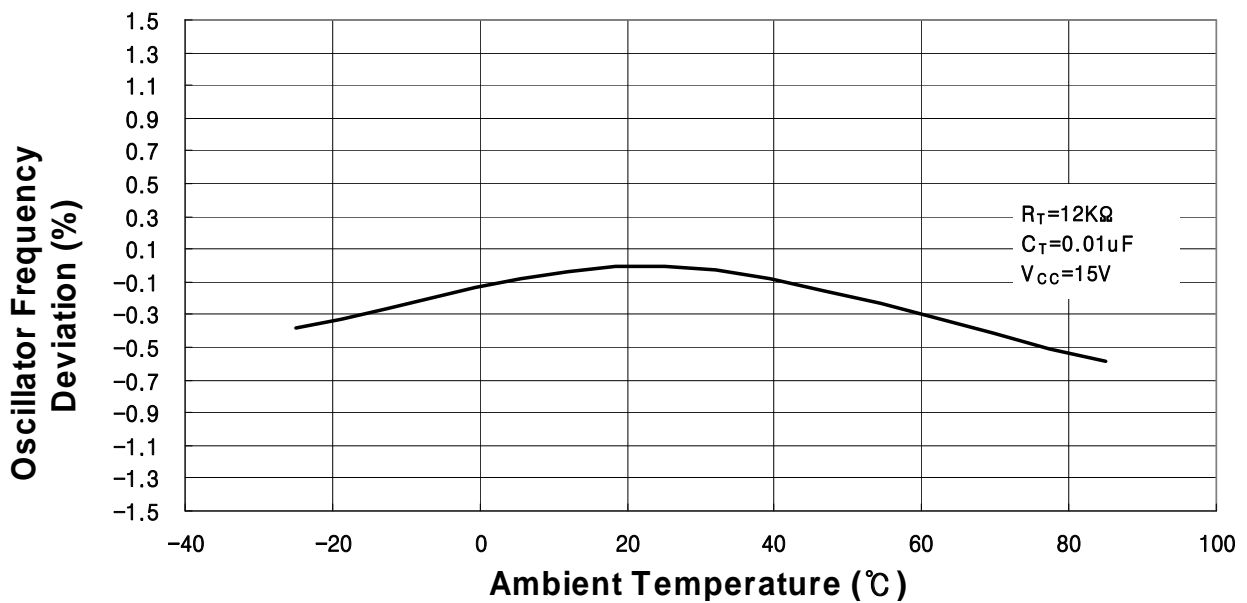
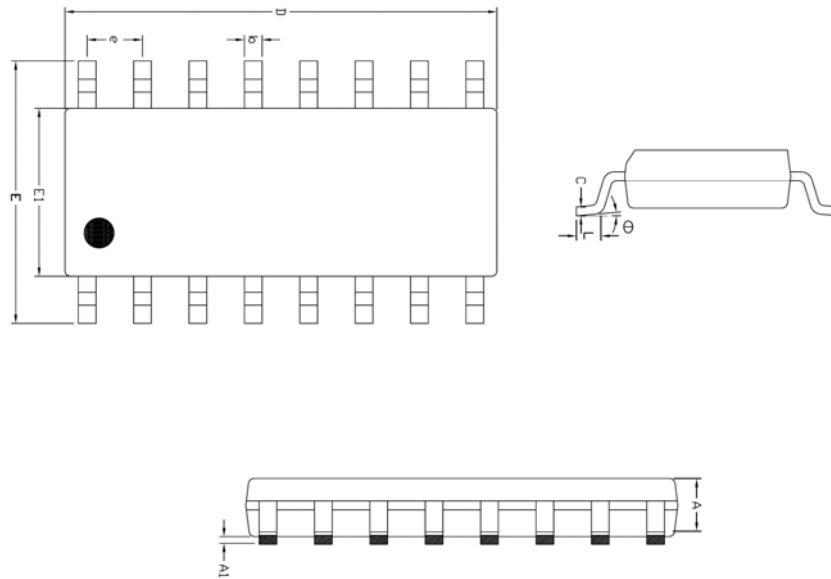

Fig.11 Frequency Deviation vs Ambient Temperature



◆ SOP-16 Outline Dimension (unit : mm)



SYMBOL	MILLIMETER(mm)			NOTE
	MINIMUM	NOMINAL	MAXIMUM	
A	1.245	—	1.445	
A1	0.125	0.175	0.275	
b	0.320	0.420	0.520	
c	0.170	0.220	0.270	
D	9.806	9.906	10.006	
E	5.870	6.020	6.170	
E1	3.761	3.861	3.961	
e	1.270 BSC			
L	0.462	0.562	0.662	
θ	0°	—	8°	

※ Recommend PCB solder land [Unit: mm]

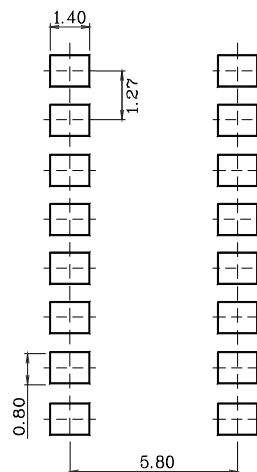

◆ DIP-16 Outline Dimension (unit : mm)

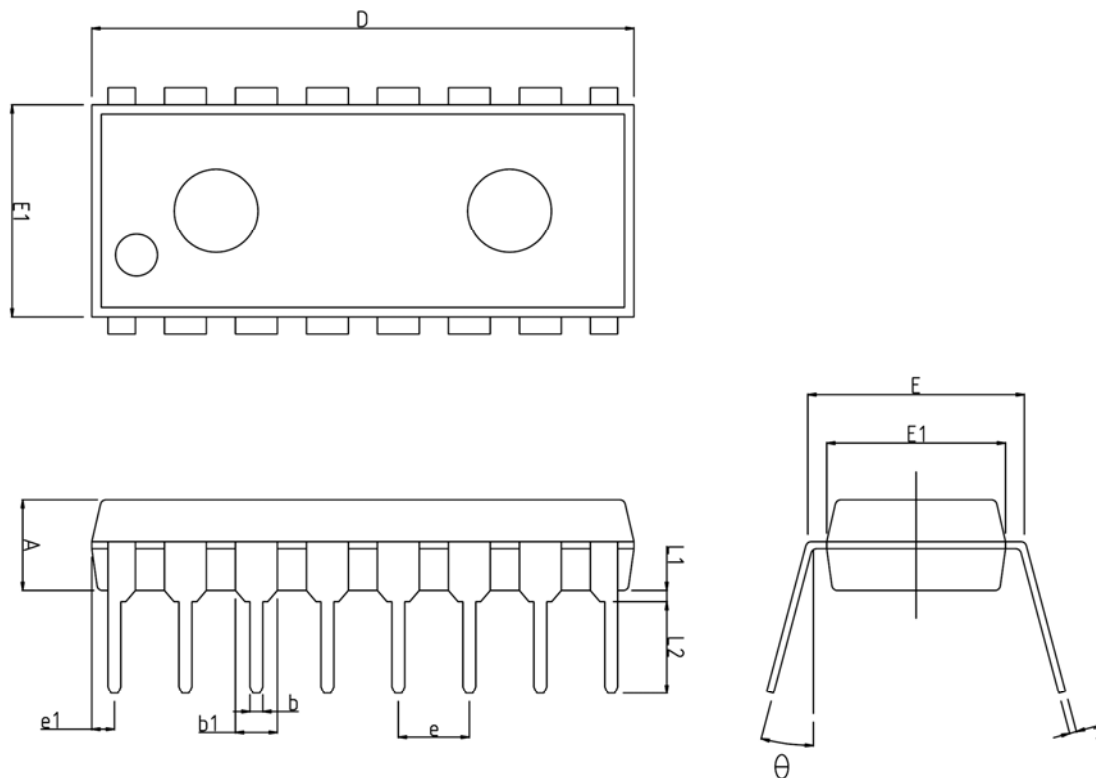

SYMBOL	MILLIMETERS			NOTE
	MINIMUM	NOMINAL	MAXIMUM	
A	3.05	3.25	3.45	
b	0.36	0.46	0.56	
b1	1.40	1.50	1.60	
c	0.20	0.25	0.35	
D	19.20	19.40	19.60	
E	7.37	7.62	7.87	
E1	6.20	6.40	6.60	
e	2.54 TYP			
e1	0.81 TYP			
L1	0.51	—	—	
L2	3.00	3.30	3.60	
θ	0°	—	15°	

The AUK Corp. products are intended for the use as components in general electronic equipment (Office and communication equipment, measuring equipment, home appliance, etc.).

Please make sure that you consult with us before you use these AUK Corp. products in equipments which require high quality and / or reliability, and in equipments which could have major impact to the welfare of human life(atomic energy control, airplane, spaceship, transportation, combustion control, all types of safety device, etc.). AUK Corp. cannot accept liability to any damage which may occur in case these AUK Corp. products were used in the mentioned equipments without prior consultation with AUK Corp..

Specifications mentioned in this publication are subject to change without notice.