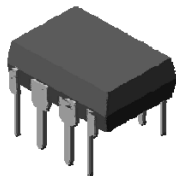
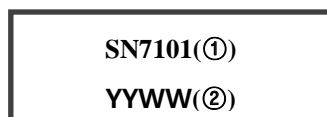

SOP-8

DIP-8

ORDERING INFORMATION

Product	Marking	Package
SN7101	SN7101	SOP-8
SN7101P	SN7101	DIP-8

▲ Marking Detail Information



- ① Device Code
- ② Week Code

Description

The SN7101 is integrated a high stability band gap voltage reference, two ORed operational amplifiers and a current source.

This IC compares the DC voltage and the current level at the output of a switching power supply to an internal reference. It provides a feedback through an Opto-coupler to the PWM controller IC in the primary side.

The controlled current generator can be used to modify the level of current limitation by offsetting the information coming from the current sensing resistor.

Features and Benefits

- ◆ 1.24V Series Voltage Reference with 10mA Output Current and 2.5% Precision
- ◆ Two Operational Amplifiers with ORed Output And 1MHz Gain Bandwidth
- ◆ Built-in Current Generator with Enable/Disable Function
- ◆ Wide Range of Supply Voltage [4.5V to 32V]

Application

- ◆ Battery chargers
- ◆ AC to DC Power Supply

Block Diagram

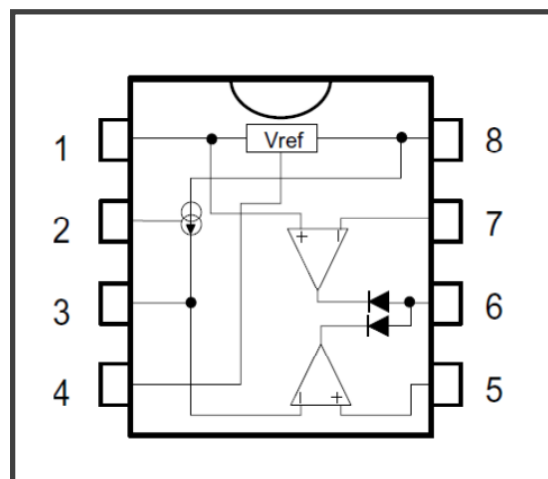

◆ Pin connection



◆ Pin Configuration

No.	Name	Function
1	Vref	Voltage Reference Output 1.24V (Max. 10mA)
2	Csen	Current Source Enable Input. This current source can be used to offset the voltage measurement on the sense resistor and therefore to modify the charge current. The current source enabled when the input voltage on pin 2 is lower than 0.8V
3	Crref	Current Limitation Reference Input
4	GND	Ground
5	Crin	Current Limitation Loop Input, connected to the sense resistor
6	Output	Output pin common to the voltage regulation and current limitation loops. This output can drive the primary side of an opto-coupler
7	Vrin	Voltage Regulation Loop Input
8	V _{CC}	Supply Voltage Input (4.5V to 32V DC)

◆ Absolute Maximum Ratings ($T_a = 25^\circ\text{C}$)

Parameter	Symbol	Limits		Unit
		SOP-8	DIP-8	
DC Supply Voltage	V_{CC}	36		V
Output Current	I_{OUT}	20		mA
Input Voltage	V_{IN}	-0.3 to $V_{CC}-1.5$		V
Power Dissipation	P_D	600	1000	mW
Maximum Junction Temperature	T_j	150		$^\circ\text{C}$
Operating Junction Temperature Range	T_{opr}	-40 ~ +105		$^\circ\text{C}$
Thermal Resistance	R_{thja}	200	130	$^\circ\text{C}/\text{W}$
Storage Temperature Range	T_{stg}	-55 ~ +150		$^\circ\text{C}$

- 1) The voltage reference is not protected against permanent short circuit.
- 2) The magnitude of input and output voltages must never exceed -0.3V or $V_{CC}-1.5\text{V}$.

◆ Operating Condition

Parameter	Symbol	Limits	Unit
Supply Voltage	VCC	4.5 to 32	V

◆ Electrical characteristics
[Operational Amplifier]
($V_{CC}=15\text{V}$, $T_A=25^\circ\text{C}$; unless otherwise specified)

Characteristic	Symbol	Test Condition	Min.	Typ.	Max.	Unit
Total Supply Current	I_{CC}	$V_{CC}=1.5\text{V}$	-	-	2.0	mA
Input Voltage Range	V_{IN}	-	0	-	$V_{CC}-1.5$	V
Input Offset Voltage	V_{IO}	$T_a = 25^\circ\text{C}$	-5	1	5	mV
		$T_{min.} < T_a < T_{max}$	-7	-	7	
Input Bias Current	I_{IB}	$V_{in}=1.2\text{V}/V_{in}=0\text{V}$, $T_a = 25^\circ\text{C}$	-700	-300	0	nA
		$T_{min.} < T_a < T_{max}$	-1000	-	0	
Output Sink Current	I_{SINK}	$V_{OL}=2.5\text{V}$, $T_a = 25^\circ\text{C}$	-	15	-	mA
		$T_{min.} < T_a < T_{max}$	8	-	-	
Large Signal Voltage Gain	A_{VO}	$R_L=2\text{K}\Omega$, $T_{min.} < T_a < T_{max}$	15	-	-	V/mV
Supply Voltage Rejection Ratio	SVR	$T_{min.} < T_a < T_{max}$	65	90	-	dB
Common Mode Rejection Ratio	CMR	$T_{min.} < T_a < T_{max}$	-	80	-	dB
Gain Bandwidth Product	GBP	$V_{CC}=30\text{V}$, $V_{in}=10\text{mV}$ $R_L=2\text{k}$, $C_L=100\text{pF}$, $f=100\text{kHz}$,	0.5	0.9	-	MHz
Output Leakage Current	I_O	$T_a = 25^\circ\text{C}$	-	-	2	uA
		$T_{min.} < T_a < T_{max}$	-	-	7	

◆ **Electrical characteristics**

[**Voltage Reference**]

($V_{CC}=15V$, $T_A=25^{\circ}C$; unless otherwise specified)

Characteristic	Symbol	Test Condition	Min.	Typ.	Max.	Unit
Reference Voltage	Vref	$I_{out}=1mA$, $T_a = 25^{\circ}C$	1.210	1.240	1.270	V
Temperature Stability	Kvt	$T_{min.} < T_a < T_{max}$	-	35	120	ppm/ $^{\circ}C$
Load Regulation	Reglo	$1mA < I_{out} < 10mA$	-	5	15	mV
Line Regulation	Regli	$5V < V_{in} < 32V$	-	3.5	10	mV

[**Current Generator**]

($V_{CC}=15V$, $T_A=25^{\circ}C$; unless otherwise specified)

Characteristic	Symbol	Test Condition	Min.	Typ.	Max.	Unit
Current Source	I_o	$T_a = 25^{\circ}C$	-	1.4	-	mA
Temperature Stability	Kcgt	$T_{min.} < T_a < T_{max}$	-	600	-	ppm/ $^{\circ}C$
Line Regulation	Cglir	$4.5V < V_{cc} < 32V$	-	0.003	0.03	mA
Current Generator Enable Voltage	Vcsen	$I_o=1.4mA$, $T_{min.} < T_a < T_{max}$	-	-	0.6	V
Current Generator Disable Voltage	Vcsdis	$I_o=0mA$, $T_{min.} < T_a < T_{max}$	2	-	-	V
Current Generator Input Current @ On the Csen Pin	Icsen	$T_{min.} < T_a < T_{max}$	-	-	30	μA
Leakage Current	Icsleak	$V_{cs}=2V$, $T_{min.} < T_a < T_{max}$	-	0.5	2.0	μA

◆ Typical application circuit

Secondary Block

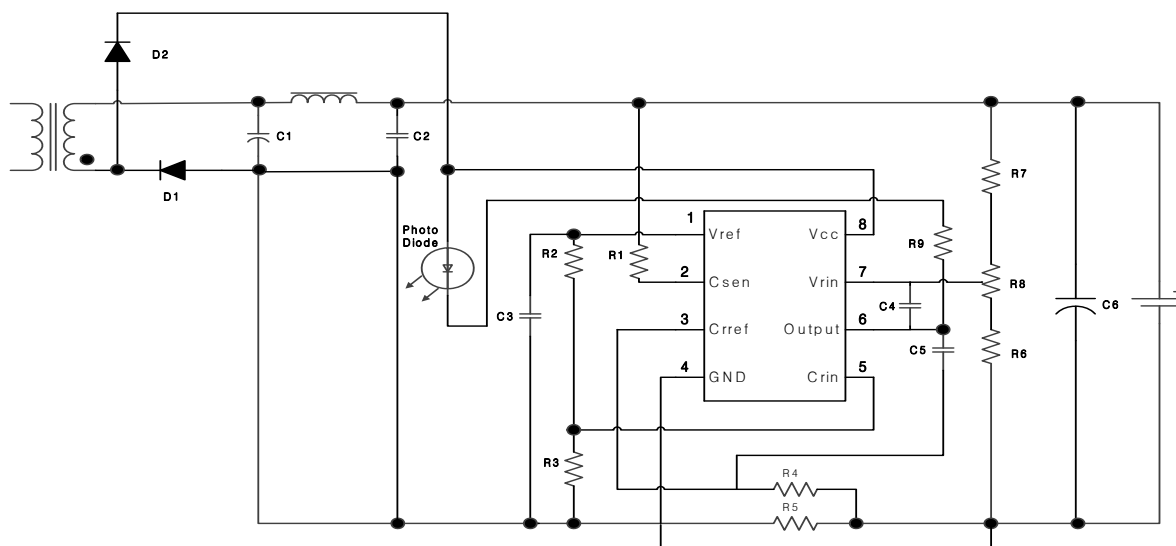

COMPONENTS CALCULATIONS

The voltage control is given by the choice of the resistor bridge R6/R7 (and the trimmer R8)

$$V_{ref} = R6/(R6+R7) \times V_{out}$$

where $V_{ref} = 1.24V$

The current control is given by the choice of the voltage drop through the sense resistor R5 (to be linked to the nominal current of the application) and by the value of the sense resistor itself.

For medium currents (< 1A), a good value for the voltage drop through R5 can be $V_{sense} = 200mV$ (dissipation < 200mW). The resistor bridge R2/R3 should be chosen following

$$V_{sense} = R3/(R2+R3) \times V_{ref}$$

The total value of the resistor bridge should be in the range of the $k\Omega$ in order to ensure a proper charge for the voltage reference (in the range of mA).

To set the current limit, the sense resistor R5 should be chosen following

$$I_{lim} = V_{sense}/R5$$

The internal current generator (I_{sce}) can be used to offset the current limitation with a lower value.

This current generator is activated by connecting pin 2 to ground. It is inhibited if pin 2 is connected to the positive rail via the pull up resistor R1. The current offset is given by the choice of the resistor R4. If I_{lim1} is the current limit calculated in the previous paragraph, and I_{lim2} is the current limit that is to be set when pin 2 is connected to ground, R4 should be chosen following

$$R4 = (V_{sense} - I_{lim2} \times R5) / I_{sce}$$

Fig.1 Reference Voltage vs. Ambient Temp.

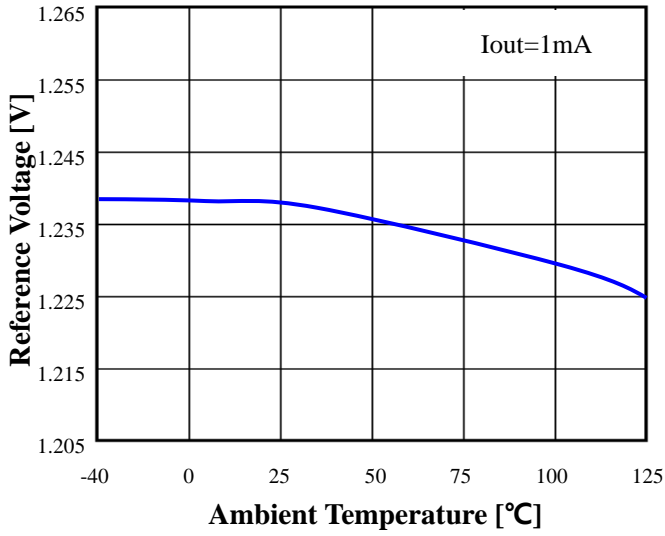

Fig.2 Supply Current vs. Ambient Temp.

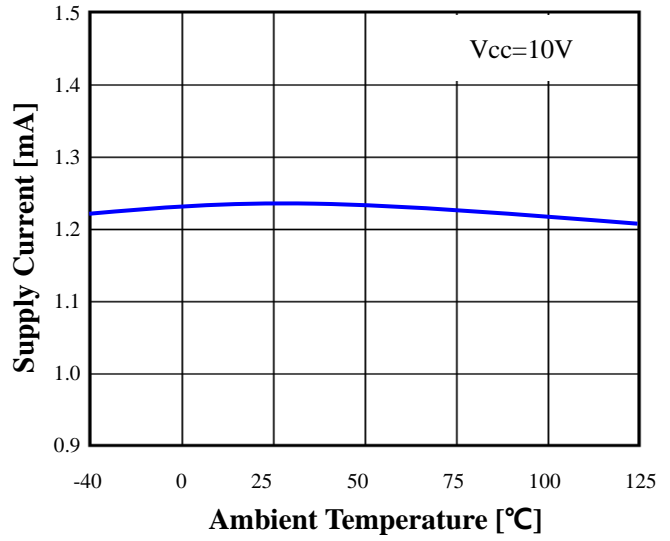

Fig.3 Reference Voltage vs. Cathode Current

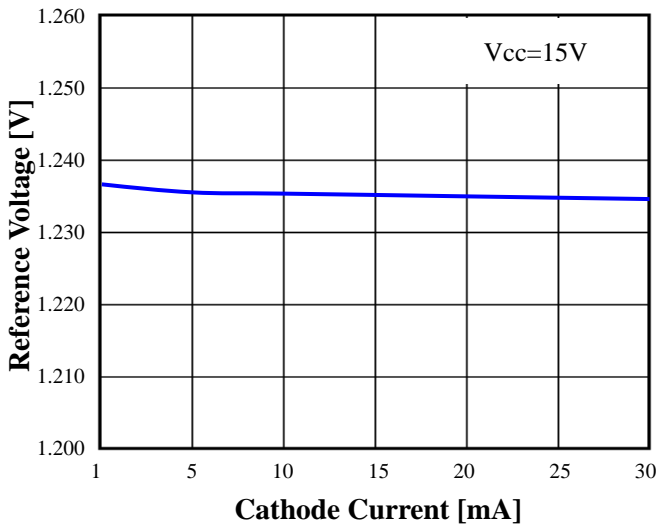

Fig.4 Input Bias Current vs. Ambient Temp.

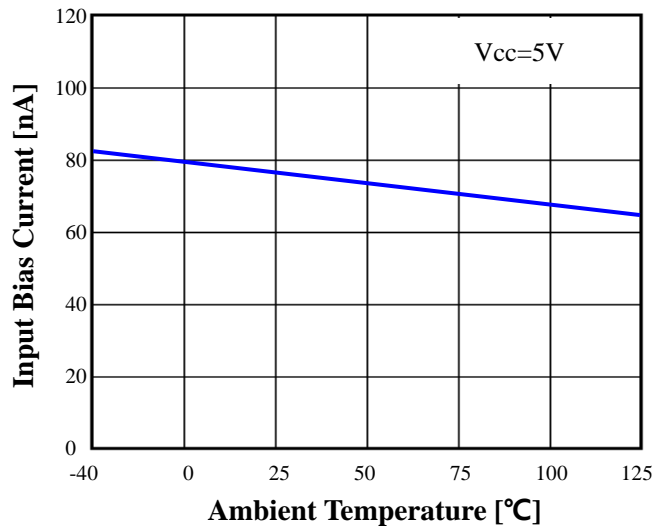
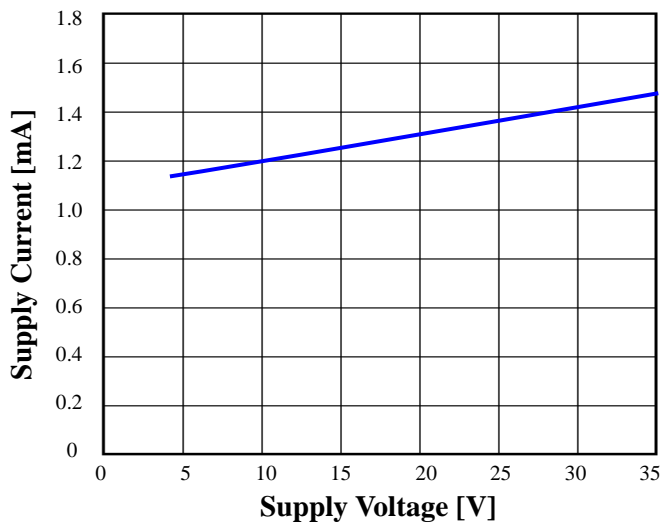
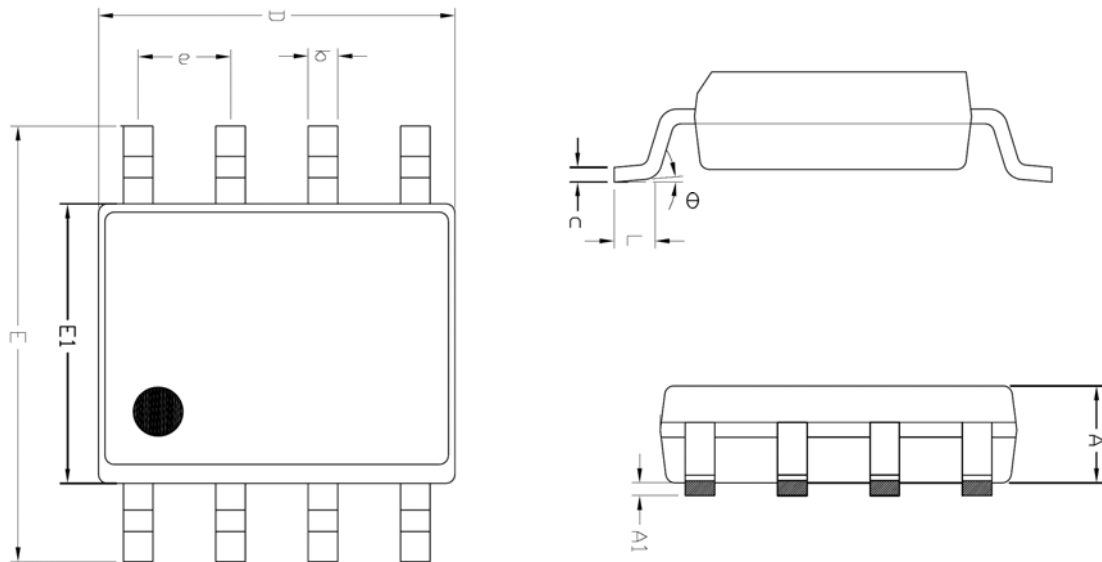

Fig.5 Supply Current vs. Supply Voltage.



Outline Dimension (Unit : mm)



SYMBOL	MILLIMETER(mm)			NOTE
	MINIMUM	NOMINAL	MAXIMUM	
A	1.245	—	1.445	
A1	0.125	0.175	0.275	
b	0.320	0.420	0.520	
c	0.170	0.220	0.270	
D	4.802	4.902	5.002	
E	5.870	6.020	6.170	
E1	3.761	3.861	3.961	
e	1.270 BSC			
L	0.462	0.562	0.662	
θ	0°	—	8°	

※ Recommend PCB solder land (Unit : mm)

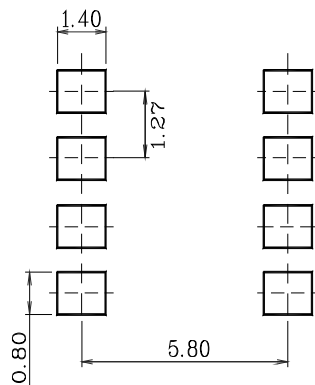

Outline Dimension (Unit : mm)

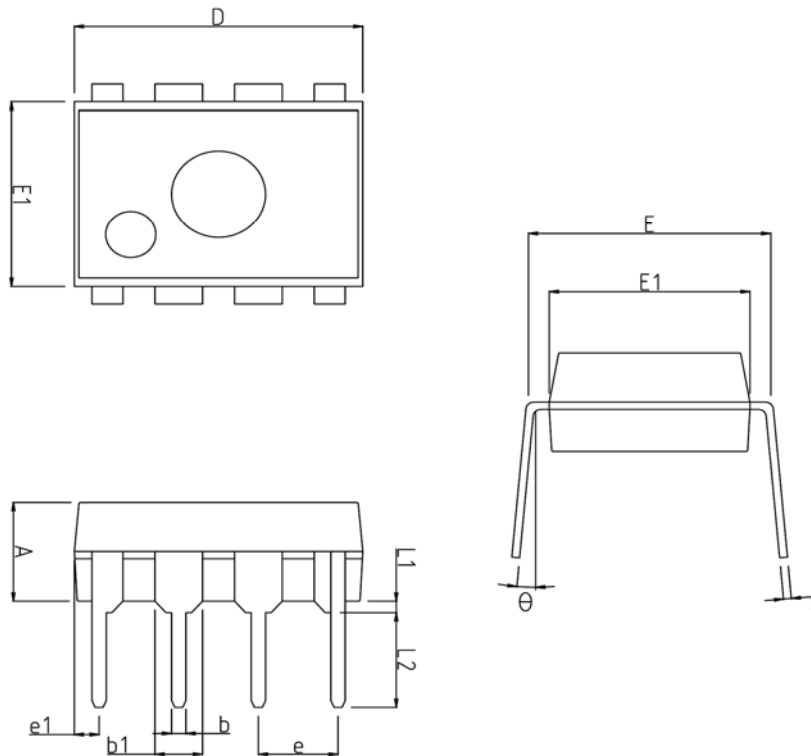

SYMBOL	MILLIMETERS			NOTE
	MINIMUM	NOMINAL	MAXIMUM	
A	3.20	3.40	3.60	
b	0.36	0.46	0.56	
b1	1.42	1.52	1.62	
c	0.20	0.25	0.35	
D	9.00	9.20	9.40	
E	7.37	7.62	7.87	
E1	6.20	6.40	6.60	
e	2.54 TYP			
e1	0.79 TYP			
L1	0.33	—	—	
L2	3.00	3.30	3.60	
θ	0°	—	15°	

The AUK Corp. products are intended for the use as components in general electronic equipment (Office and communication equipment, measuring equipment, home appliance, etc.).

Please make sure that you consult with us before you use these AUK Corp. products in equipments which require high quality and / or reliability, and in equipments which could have major impact to the welfare of human life(atomic energy control, airplane, spaceship, transportation, combustion control, all types of safety device, etc.). AUK Corp. cannot accept liability to any damage which may occur in case these AUK Corp. products were used in the mentioned equipments without prior consultation with AUK Corp..

Specifications mentioned in this publication are subject to change without notice.

 KODENSHI AUK 광전자(주)	제*개정 이력	문서체계	규격
		문서제목	SN7101/P
		문서번호	KSD-I7F019

개정 번호	제*개정 일자	개정 부분	개정 내용 / 참고 사항
000	2011.12.05	신규제정	신규제정