

Description

The SN4560 is dual operational amplifiers which achieve approximately twice the high output current of the SN4560, as well as featuring a higher slew rate of 4V/us, a gain band width of 10MHz, and an improved frequency characteristic.

Features

- Built-in output short-circuit protection circuit.
- Internal phase correction.
- No latch-up
- Wide same phase mode and differential voltage ranges
- High gain. low noise

Applications

- Active filters
- Audio amplifiers
- VCOs
- Other electronic circuits

Ordering Information

Type NO.	Marking	Package Code
SN4560	SN4560	SOP-8

Pin Assignment & Block Diagram

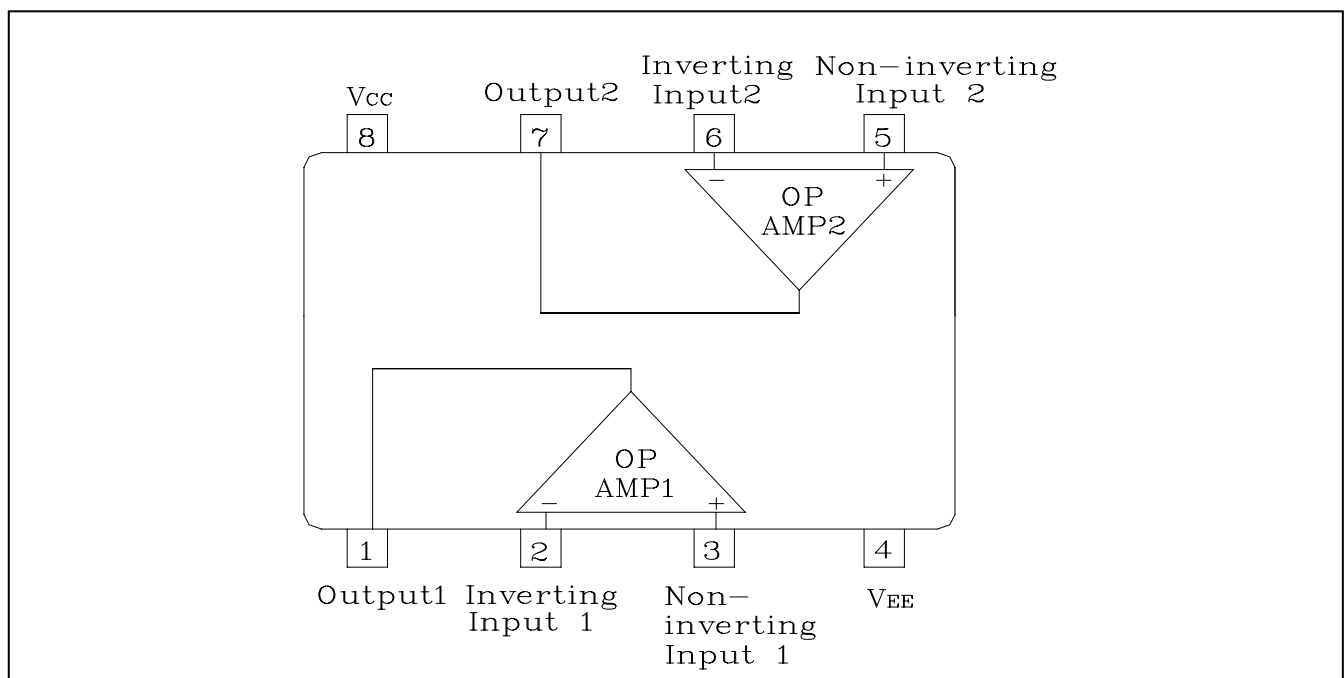

Absolute maximum ratings

(Ta = 25 °C)

Characteristic	Symbol	Ratings	Unit
Supply voltage	V _{CC}	±18	V
Differential input voltage	V _{ID}	±30	V
Input voltage	V _{IC}	-V _{CC} ~ V _{CC}	V
Power Dissipation	P _D *	550	mW
Operating temperature	T _{opr}	-40 ~ +85	°C
Storage temperature	T _{stg}	-55 ~ +125	°C

* Refer to Pd characteristics diagram. The values for the SN4560 are those when it is mounted on a glass epoxy PCB(50 mm×50 mm×1.6 mm).

Electrical Characteristics

(Unless otherwise specified. V_{CC} = +15V, V_{EE} = -15V and Ta = 25 °C)

Characteristic	Symbol	Test Condition	Min.	Typ.	Max.	Unit
Input offset voltage	V _{IOS}	R _g ≤ 10 kΩ	-	0.5	6	mV
Input offset current	I _{IOS}	-	-	5	200	nA
Input bias current	I _{IB}	-	-	50	500	nA
Input common mode Voltage Range	V _{ICR}	-	±12	±14	-	V
Maximum Output Voltage	V _{OM}	R _L ≥ 10 kΩ	±12	±14	-	V
		R _L ≥ 2 kΩ	±10	±13	-	V
Large signal Voltage Gain	G _V	V _{out} = ±10V, R _L ≥ 2 kΩ	86	100	-	dB
Common mode rejection ratio	CMRR	R _g ≤ 10 kΩ	70	90	-	dB
Power supply rejection ratio	PSRR	R _g ≤ 10 kΩ	-	30	150	uV/V
Slew Rate	SR	G _V = 1, R _L ≥ 2 kΩ	-	4.0	-	V/us
Input conversion noise voltage	V _n	-	-	-	2.2	uV
Gain band width product	GBW	f = 10kHz	-	10	-	MHz

Electrical Characteristic Curves

Fig. 1 $G_V - f$

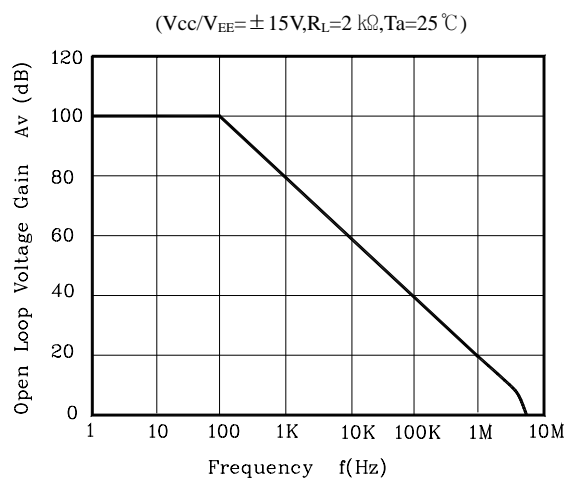

Fig. 2 $V_{OP-P} - f$

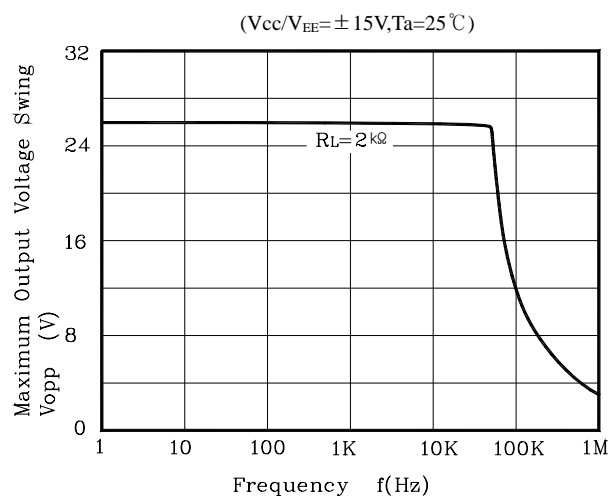

Fig. 3 $I_{IB} - T_a$

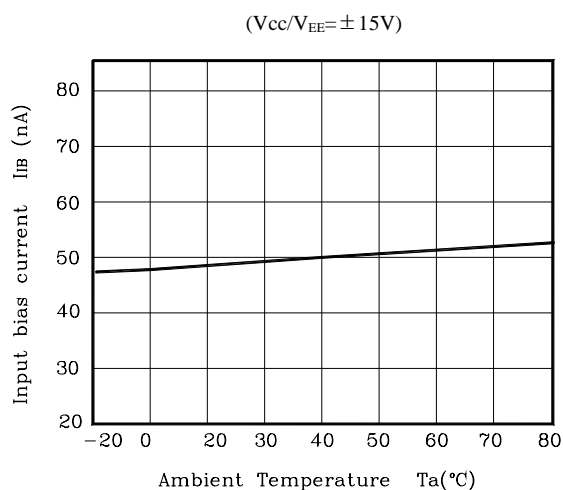

Fig. 4 $V_{ICR} - V_{CC} / V_{EE}$

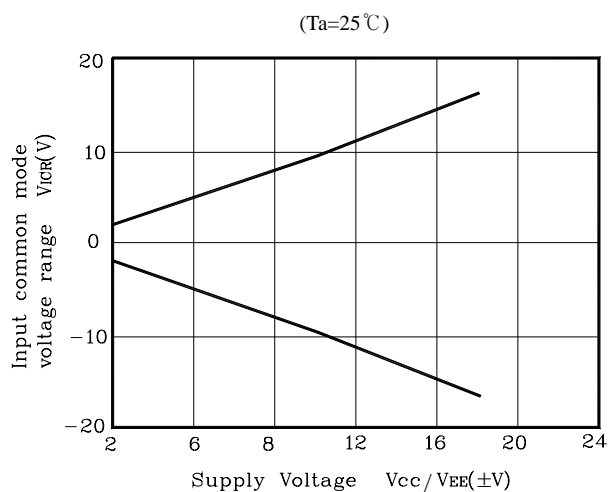

Fig. 5 $I_Q - V_{CC} / V_{EE}$

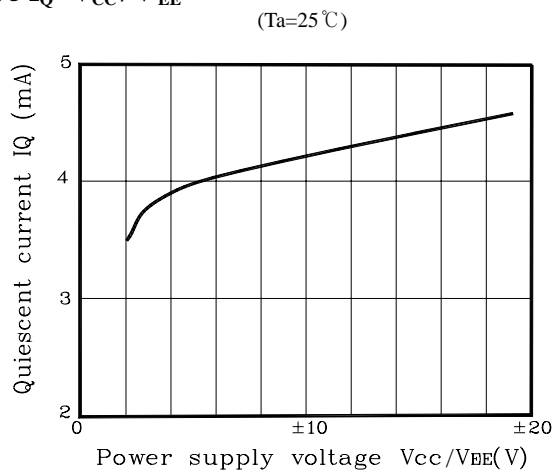
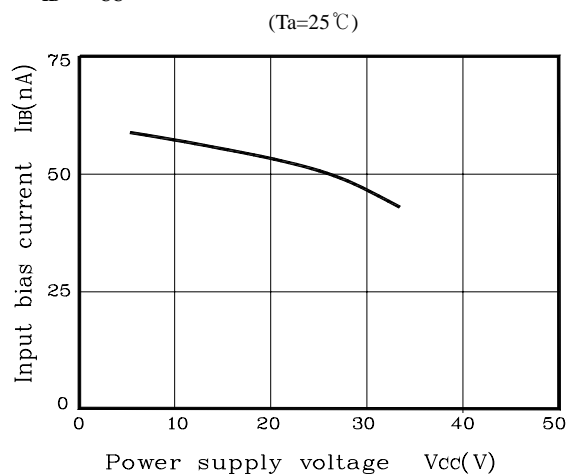
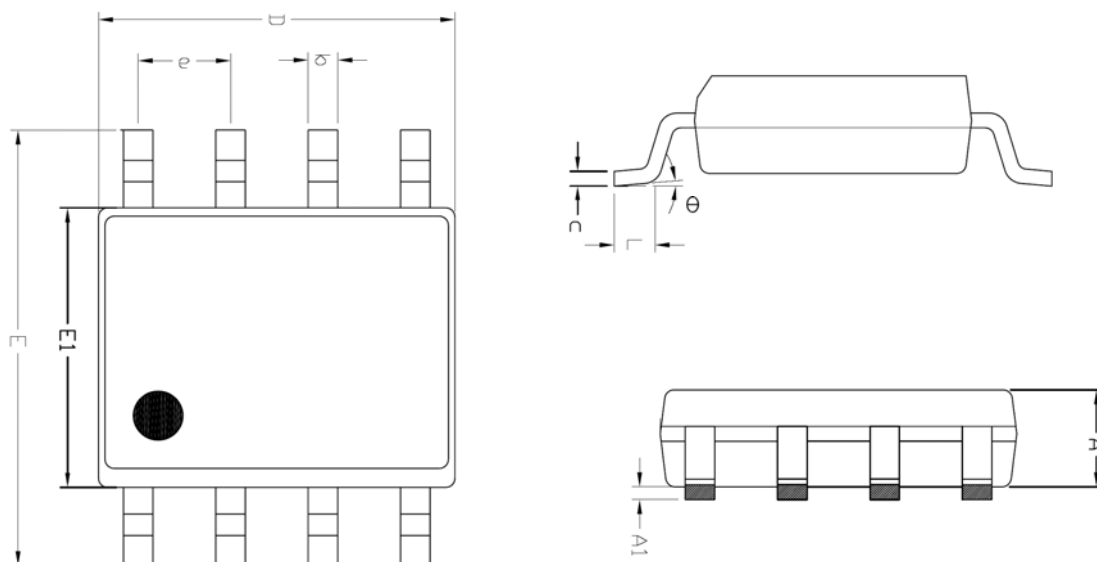

Fig. 6 $I_{IB} - V_{CC}$



Outline Dimension (Unit : mm)



SYMBOL	MILLIMETER(mm)			NOTE
	MINIMUM	NOMINAL	MAXIMUM	
A	1.245	—	1.445	
A1	0.125	0.175	0.275	
b	0.320	0.420	0.520	
c	0.170	0.220	0.270	
D	4.802	4.902	5.002	
E	5.870	6.020	6.170	
E1	3.761	3.861	3.961	
e	1.270 BSC			
L	0.462	0.562	0.662	
θ	0°	—	8°	

※ Recommend PCB solder land (Unit : mm)

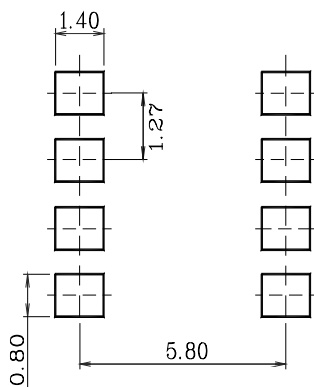

The AUK Corp. products are intended for the use as components in general electronic equipment (Office and communication equipment, measuring equipment, home appliance, etc.).

Please make sure that you consult with us before you use these AUK Corp. products in equipments which require high quality and / or reliability, and in equipments which could have major impact to the welfare of human life(atomic energy control, airplane, spaceship, transportation, combustion control, all types of safety device, etc.). AUK Corp. cannot accept liability to any damage which may occur in case these AUK Corp. products were used in the mentioned equipments without prior consultation with AUK Corp..

Specifications mentioned in this publication are subject to change without notice.