

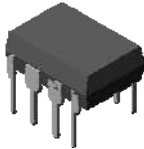
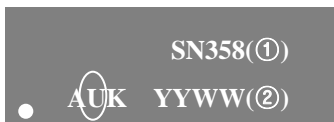

**SOP-8**

**DIP-8**
**ORDERING INFORMATION**

Product	Marking	Package
SN358	SN358	SOP-8
SN358P	SN358P	DIP-8

**▲ Marking Information**

① Device Code

② Year &amp; Week Code

**Description**

The SN358/P consists of two independent high gain

Internally frequency compensated operational amplifiers

designed to operate from a single power supply over a wide range of voltage.

**Application**

- ◆ Transducer amplifier
- ◆ DC gain blocks
- ◆ Conventional operational amplifiers

**Features and Benefits**

- ◆ Input common mode voltage range includes ground
- ◆ Internally frequency compensated for unity gain
- ◆ Large DC voltage gain : 100dB
- ◆ Wide bandwidth for unity gain : 1 MHz
- ◆ Very low power consumption
- ◆ Wide supply voltage range :  
[ Single : 3V ~ 30V, Dual : ±1.5 ~ ±15V ]

## ◆ Internal Block Diagram

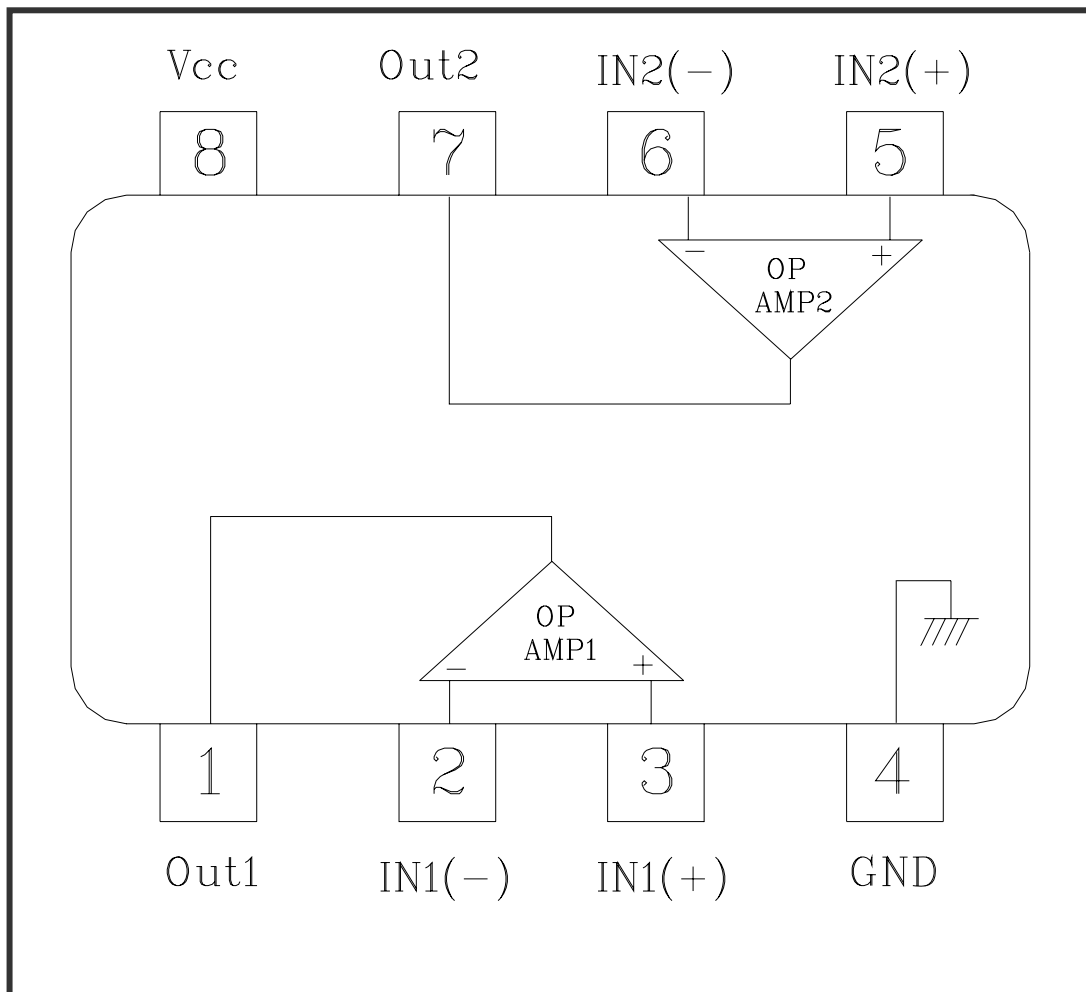

## ◆ Pin Description

No	Symbol	I/O	Description
1	Out1	O	OP-Amp1 Output
2	IN1(-)	I	OP-Amp1's Inverting Input
3	IN1(+)	I	OP-Amp1's Non-inverting Input
4	GND	GND	GND
5	IN2(+)	I	OP-Amp2's Non-inverting Input
6	IN2(-)	I	OP-Amp2's Inverting Input
7	Out2	O	OP-Amp2 Output
8	V <sub>CC</sub>	PWR	V <sub>CC</sub> for Dual Operational Amplifier

## Absolute maximum ratings

Characteristic	Symbol	Ratings	Unit	
Supply voltage	$V_{CC}$	36 or $\pm 18$	V	
Differential input voltage	$V_{IND}$	32	V	
Input voltage	$V_{IN}$	-0.3 ~ +32	V	
Power Dissipation	$P_D$	SOP-8	600	mW
		DIP-8	1000	mW
Operating temperature	$T_{opr}$	-45 ~ +85	$^{\circ}C$	
Storage temperature	$T_{stg}$	-55 ~ 150	$^{\circ}C$	

## Electrical Characteristics

(Unless otherwise specified.  $V_{CC} = 5V$  and  $-45^{\circ}C \leq T_a \leq +85^{\circ}C$ )

Characteristic	Symbol	Test Condition	Min.	Typ.	Max.	Unit	
Input offset voltage	$V_{IOS}$	$5V \leq V_{CC} \leq 30V$ (Ta=25 $^{\circ}C$ )	-	$\pm 2$	$\pm 7$	mV	
		$R_g = 0\Omega, 0V \leq V_{IC} \leq V_{CC} - 1.5V$	-	-	$\pm 9$		
Input offset voltage drift	$\Delta V_{IOS}/\Delta T$	$R_g = 0\Omega$	-	7	-	$\mu V/^{\circ}C$	
Input offset current	$I_{IOS}$	-	(Ta=25 $^{\circ}C$ )	-	$\pm 5$	$\pm 50$	nA
			-	-	$\pm 150$		
Input offset current drift	$\Delta I_{IOS}/\Delta T$	-	-	10	-	$pA/^{\circ}C$	
Input bias current	$I_{IB}$	-	(Ta=25 $^{\circ}C$ )	-	45	250	nA
			-	-	40	500	
Input common mode voltage range	$V_{ICR}$	$V_{CC} = 30V$	(Ta=25 $^{\circ}C$ )	0	-	$V_{CC} - 1.5$	V
			-	0	-	$V_{CC} - 2$	V
Supply current	$I_{CC}$	$V_{CC} = 30V, R_L = \infty$	-	1	2	mA	
		$V_{CC} = 5V, R_L = \infty$	-	0.7	1.2		
Large signal voltage gain	$G_V$	$V_{CC} = 15V$ $R_L \geq 2 K\Omega$	(Ta=25 $^{\circ}C$ )	25	100	-	V/mV
			-	15	-	-	
Output voltage swing	$V_{OH}$	$V_{CC} = 30V$	$R_L = 2 K\Omega$	26	-	-	V
			$R_L = 10 K\Omega$	27	28	-	
	$V_{OL}$	$V_{CC} = 5V, R_L \leq 10 K\Omega$	-	3	20	mV	
Common mode rejection ratio	CMRR	(Ta=25 $^{\circ}C$ )	65	90	-	dB	
Power supply rejection ratio	PSRR	(Ta=25 $^{\circ}C$ )	65	100	-	dB	
Output source current	$I_{O+}$	$V_{CC} = 15V$ (Ta=25 $^{\circ}C$ )	20	40	-	mA	
		$V_{IN+} = 1V, V_{IN-} = 0V$	10	20	-		
Output sink current	$I_{O-}$	$V_{CC} = 15V$ (Ta=25 $^{\circ}C$ )	10	20	-	mA	
		$V_{IN+} = 0V, V_{IN-} = 1V$	5	8	-		
		$V_{OUT} = 200mV,$ $V_{IN+} = 0V, V_{IN-} = 1V$ (Ta=25 $^{\circ}C$ )	12	50	-	$\mu A$	
Output short circuit to ground	$I_{SC}$	Ta=25 $^{\circ}C$	-	40	60	mA	

Typical Applications

Inverting Amplifier

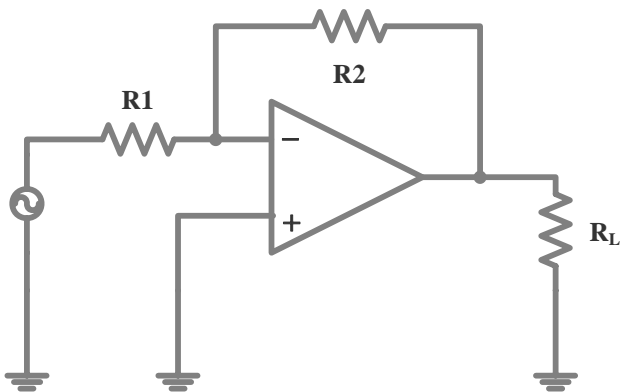

Non-inverting Amplifier

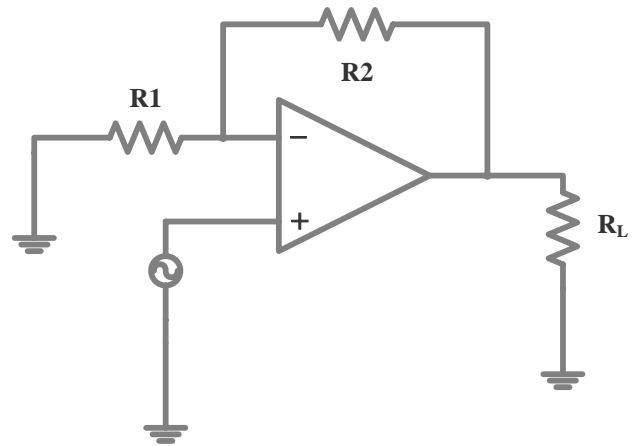

Power Amplifier

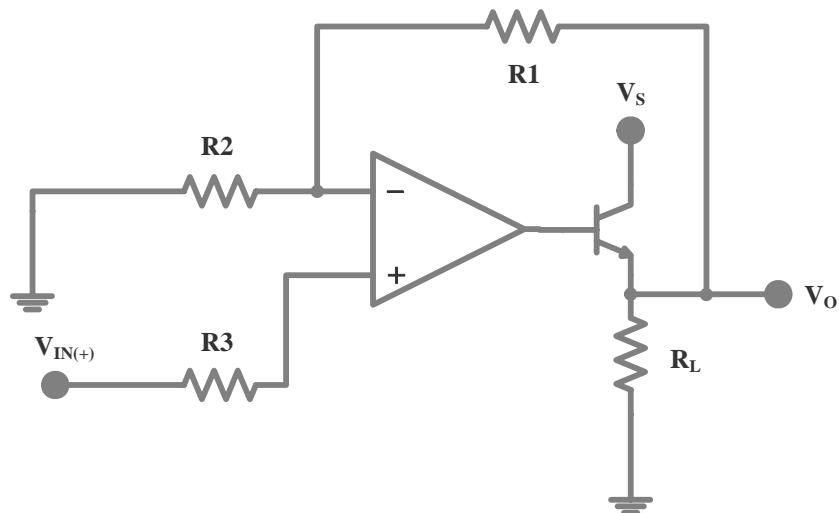

Fixed Current Sources

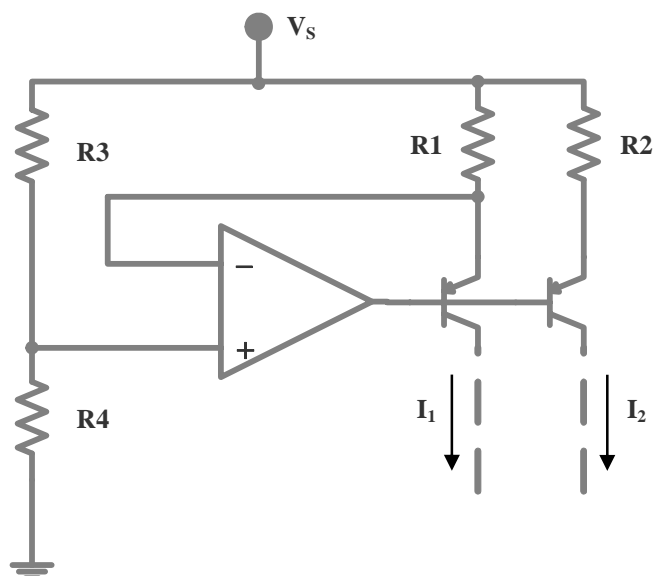

### Electrical Characteristic Curves

Fig. 1  $I_{CC}-V_{CC}$

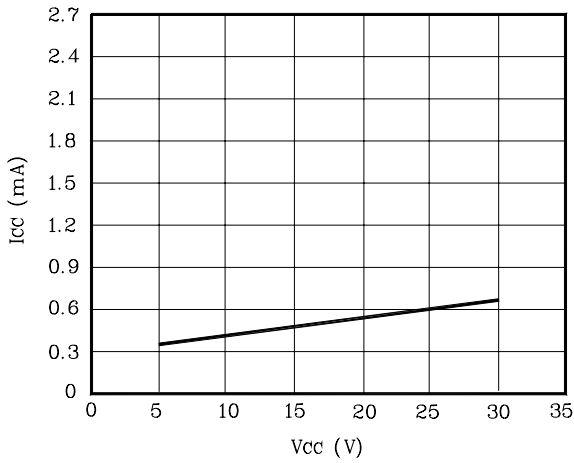

Fig. 2  $I_{IB}-V_{CC}$

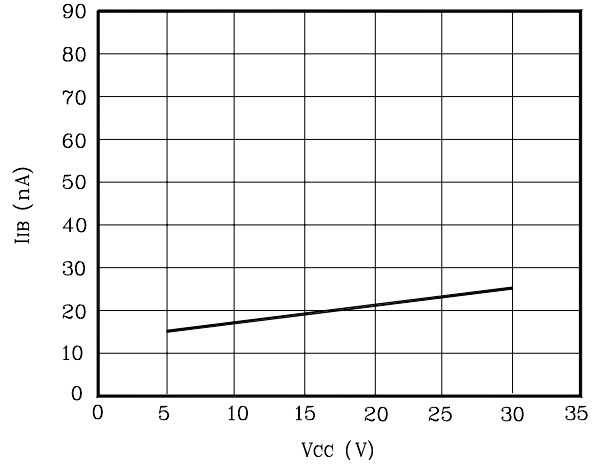

Fig. 3  $V_{IOS}-T_a$

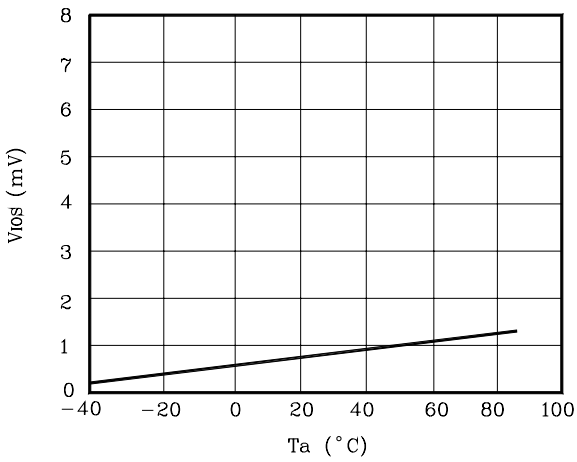

Fig. 4  $I_{O+}-T_a$

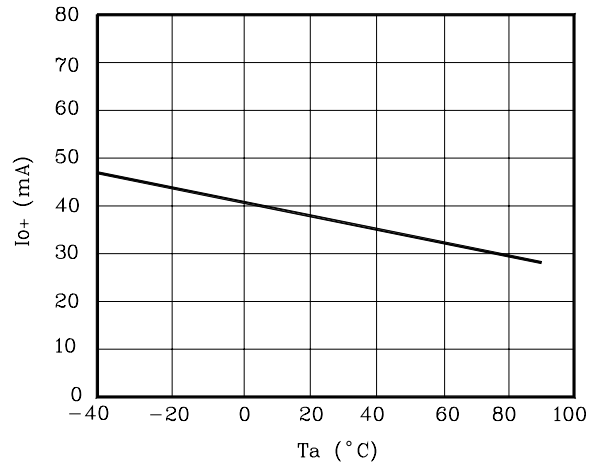

Fig. 5 CMRR-f

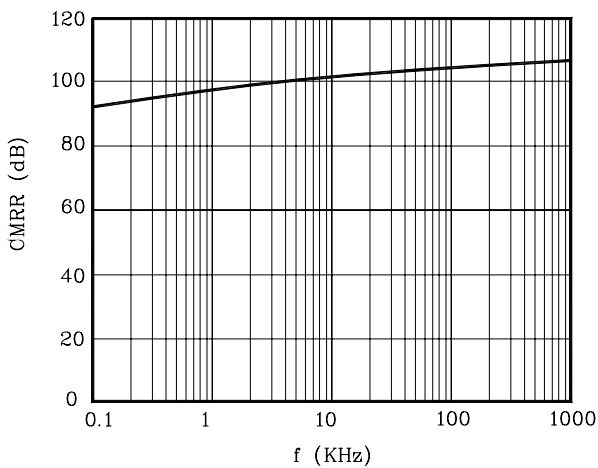
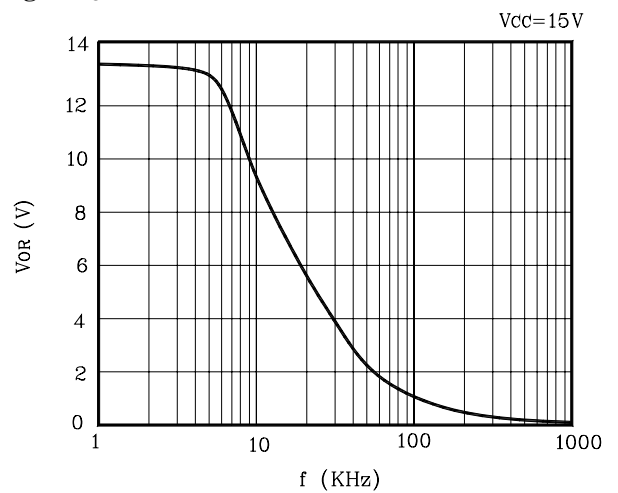
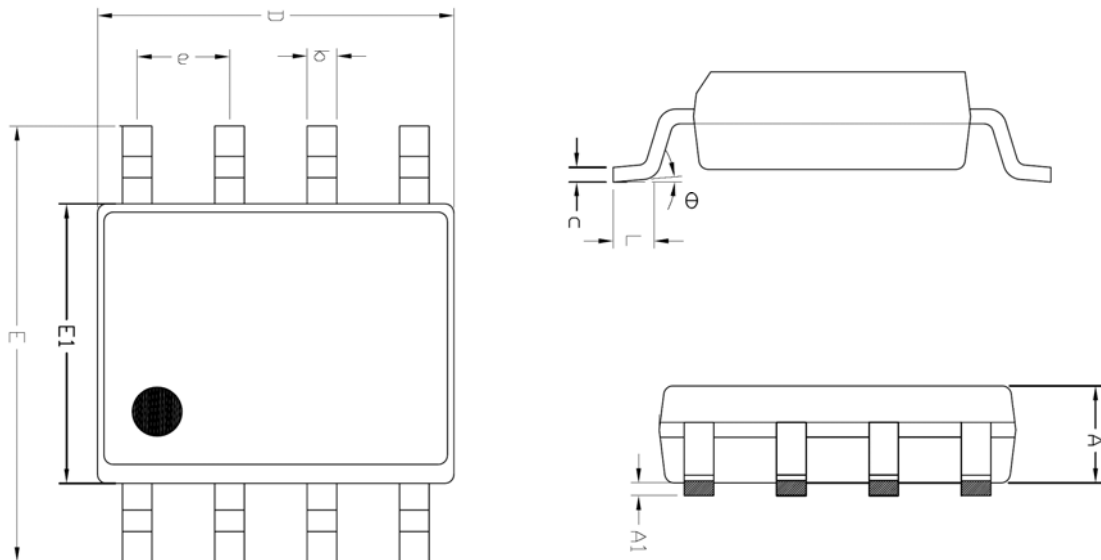

Fig. 6  $V_{OR}-f$



## Outline Dimension (Unit : mm)



SYMBOL	MILLIMETER(mm)			NOTE
	MINIMUM	NOMINAL	MAXIMUM	
A	1.245	—	1.445	
A1	0.125	0.175	0.275	
b	0.320	0.420	0.520	
c	0.170	0.220	0.270	
D	4.802	4.902	5.002	
E	5.870	6.020	6.170	
E1	3.761	3.861	3.961	
e	1.270 BSC			
L	0.462	0.562	0.662	
θ	0 °	—	8 °	

## ※ Recommend PCB solder land (Unit : mm)

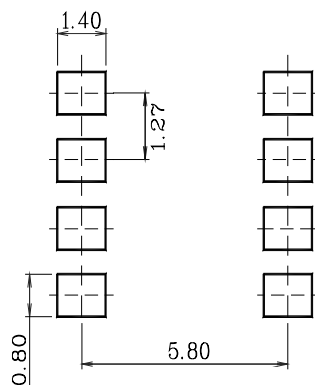

Outline Dimension (Unit : mm)

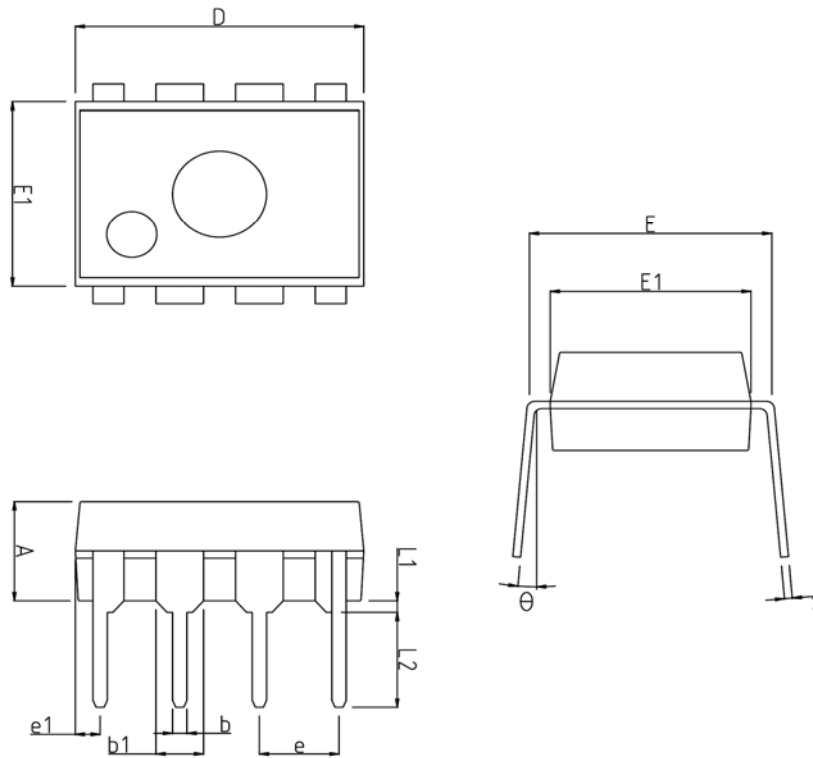

SYMBOL	MILLIMETERS			NOTE
	MINIMUM	NOMINAL	MAXIMUM	
A	3.20	3.40	3.60	
b	0.36	0.46	0.56	
b1	1.42	1.52	1.62	
c	0.20	0.25	0.35	
D	9.00	9.20	9.40	
E	7.37	7.62	7.87	
E1	6.20	6.40	6.60	
e	2.54 TYP			
e1	0.79 TYP			
L1	0.33	—	—	
L2	3.00	3.30	3.60	
$\theta$	0°	—	15°	

**The AUK Corp. products are intended for the use as components in general electronic equipment (Office and communication equipment, measuring equipment, home appliance, etc.).**

**Please make sure that you consult with us before you use these AUK Corp. products in equipments which require high quality and / or reliability, and in equipments which could have major impact to the welfare of human life(atomic energy control, airplane, spaceship, transportation, combustion control, all types of safety device, etc.). AUK Corp. cannot accept liability to any damage which may occur in case these AUK Corp. products were used in the mentioned equipments without prior consultation with AUK Corp..**

**Specifications mentioned in this publication are subject to change without notice.**