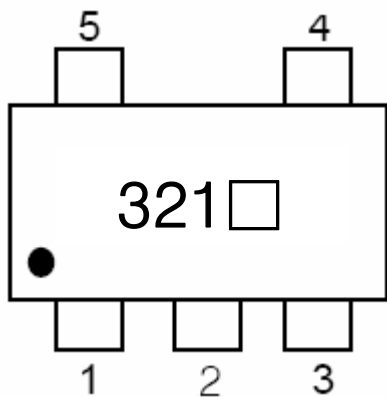

SOT-25
ORDERING INFORMATION

Product Name.	Marking	Package Name
SN321	321□	SOT-25

[Marking Detail Information]
321 : P/N Marking
□ : Year & Week Code
Description

The SN321 consists of a high gain Internally frequency compensated operational amplifier designed to operate from a single power supply over a wide range of voltage.

The input common mode range includes ground and the device is able to operate in single supply applications, even in dual supply applications. it is also can be driven large capacitive loads.

The SN321 is available in the SOT-25(SOT23-5) package.

Application

- ◆ Power supplies
- ◆ Chargers
- ◆ Desktops
- ◆ Conventional operational amplifiers
- ◆ Communications infrastructure

Features and Benefits

- ◆ Input common mode voltage range includes ground
- ◆ Internally frequency compensated for unity gain
- ◆ Large DC voltage gain : 100dB
- ◆ Wide bandwidth for unity gain : 1 MHz
- ◆ Very low power consumption
- ◆ Wide supply voltage range :
[Single : 3V ~ 30V, Dual : ±1.5 ~ ±15V]

◆ Internal Block Diagram

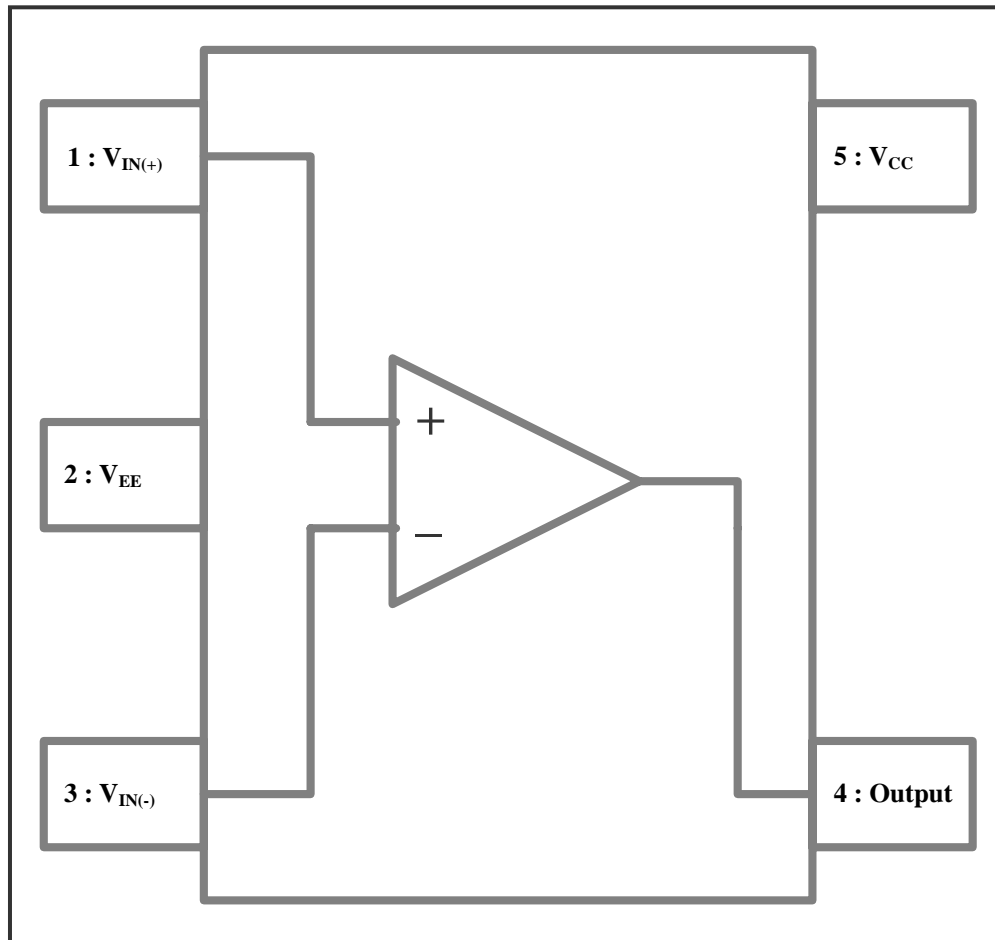

◆ Pin Description

No	Symbol	I/O	Description
1	$V_{IN(+)}$	I	OP-Amp's Non-inverting Input
2	V_{EE}	GND	GND
3	$V_{IN(-)}$	I	OP-Amp's Inverting Input
4	Output	O	Output
5	V_{CC}	V_{CC}	V_{CC} for OP-AMP

Absolute maximum ratings

Characteristic	Symbol	Ratings	Unit
Supply voltage	V_{CC}	36 or ± 18	V
Differential input voltage	V_{IND}	32	V
Input voltage	V_{IN}	-0.3 ~ +32	V
Power Dissipation	P_D	300	mW
Operating temperature	T_{opr}	-45 ~ +85	$^{\circ}C$
Storage temperature	T_{stg}	-55 ~ 150	$^{\circ}C$

* Mount on a glass epoxy circuit board of 30x30mm Pad dimension of 50mm²

Electrical Characteristics

(Unless otherwise specified. $V_{CC} = 5V$ and $-45^{\circ}C \leq T_a \leq +85^{\circ}C$)

Characteristic	Symbol	Test Condition	Min.	Typ.	Max.	Unit	
Input offset voltage	V_{IOS}	$5V \leq V_{CC} \leq 30V$ (Ta=25 $^{\circ}C$)	-	± 2	± 7	mV	
		$R_g = 0\Omega, 0V \leq V_{IC} \leq V_{CC}-1.5V$	-	-	± 9		
Input offset voltage drift	$\Delta V_{IOS}/\Delta T$	$R_g = 0\Omega$	-	7	-	$\mu V/^{\circ}C$	
Input offset current	I_{IOS}	-	(Ta=25 $^{\circ}C$)	-	± 5	± 50	nA
				-		± 150	
Input offset current drift	$\Delta I_{IOS}/\Delta T$	-	-	10	-	pA/ $^{\circ}C$	
Input bias current	I_{IB}	-	(Ta=25 $^{\circ}C$)	-	45	250	nA
				-	40	500	
Input common mode voltage range	V_{ICR}	$V_{CC} = 30V$	(Ta=25 $^{\circ}C$)	0	-	$V_{CC}-1.5$	V
				0	-	$V_{CC}-2$	V
Supply current	I_{CC}	$V_{CC} = 30V, R_L = \infty$	-	1	2	mA	
		$V_{CC} = 5V, R_L = \infty$	-	0.7	1.2		
Large signal voltage gain	G_V	$V_{CC} = 15V$ $R_L \geq 2 K\Omega$	(Ta=25 $^{\circ}C$)	25	100	-	V/mV
				15	-	-	
Output voltage swing	V_{OH}	$V_{CC} = 30V$	$R_L = 2 K\Omega$	26	-	-	V
			$R_L = 10 K\Omega$	27	28	-	
	V_{OL}	$V_{CC} = 5V, R_L \leq 10 K\Omega$	-	3	20	mV	
Common mode rejection ratio	CMRR	(Ta=25 $^{\circ}C$)	65	90	-	dB	
Power supply rejection ratio	PSRR	(Ta=25 $^{\circ}C$)	65	100	-	dB	
Output source current	I_{O+}	$V_{CC} = 15V$ (Ta=25 $^{\circ}C$)	20	40	-	mA	
		$V_{IN+} = 1V, V_{IN-} = 0V$	10	20	-		
Output sink current	I_{O-}	$V_{CC} = 15V$ (Ta=25 $^{\circ}C$)	10	20	-	mA	
		$V_{IN+} = 0V, V_{IN-} = 1V$	5	8	-		
		$V_{OUT} = 200mV,$ $V_{IN+} = 0V, V_{IN-} = 1V$ (Ta=25 $^{\circ}C$)	12	50	-	μA	
Output short circuit to ground	I_{SC}	Ta=25 $^{\circ}C$	-	40	60	mA	

Electrical Characteristic Curves

Fig. 1 $I_{CC}-V_{CC}$

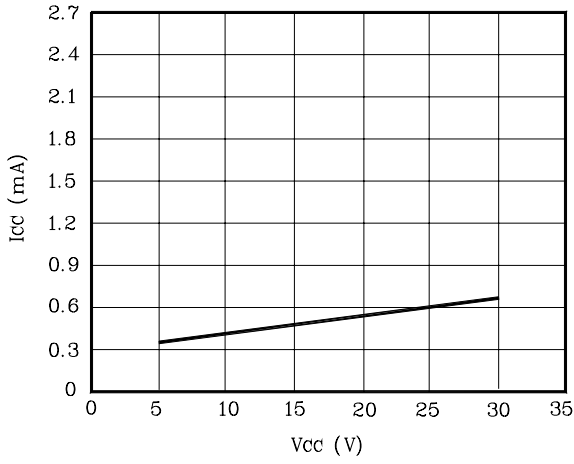

Fig. 2 $I_{IB}-V_{CC}$

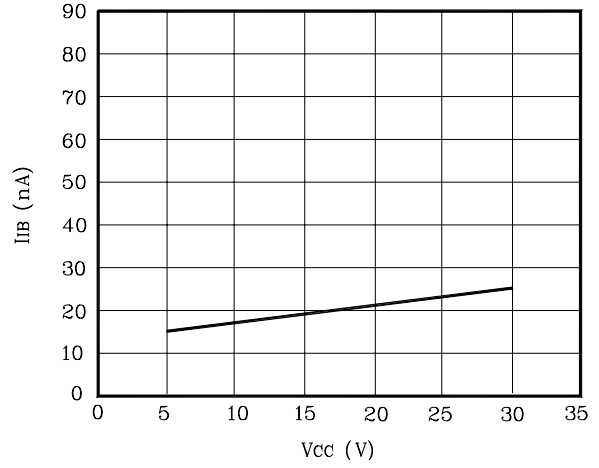

Fig. 3 $V_{IOS}-T_a$

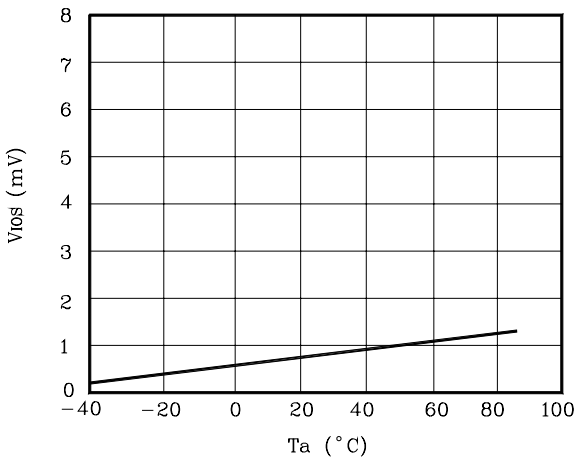

Fig. 4 I_O-T_a

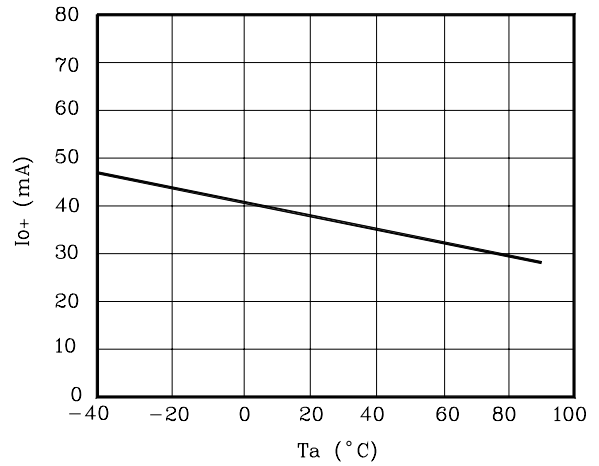

Fig. 5 CMRR-f

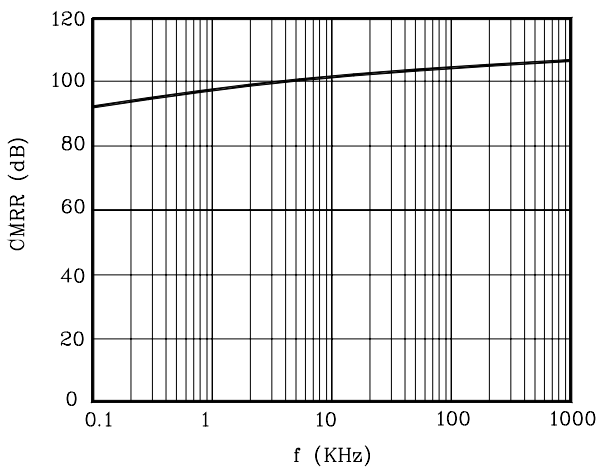
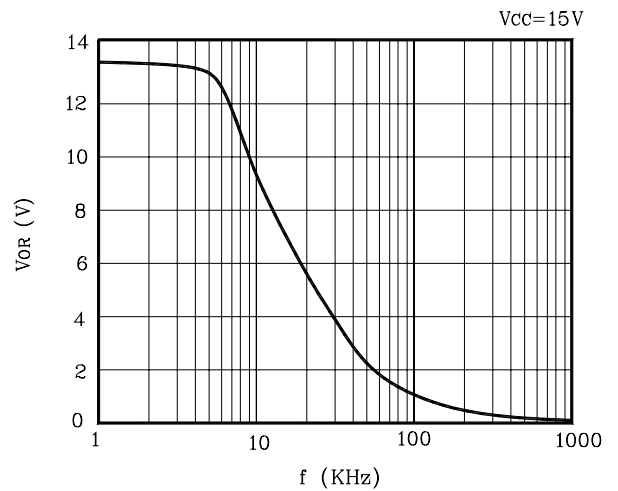
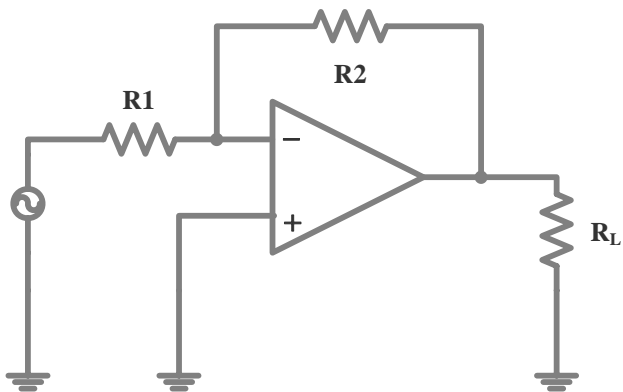

Fig. 6 $V_{OR}-f$



Typical Applications

Inverting Amplifier



Non-inverting Amplifier

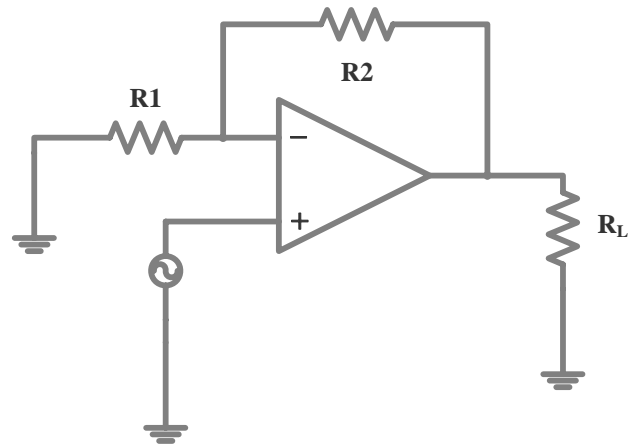

Power Amplifier

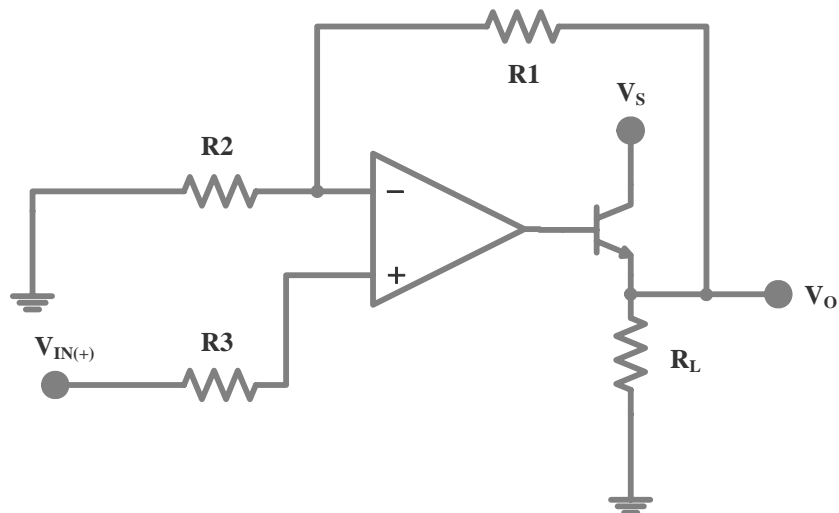

Fixed Current Sources

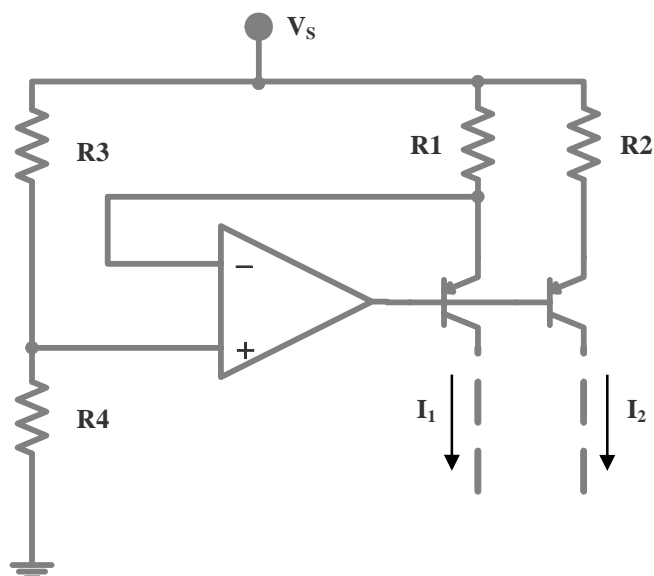

Outline Dimension (Unit : mm)

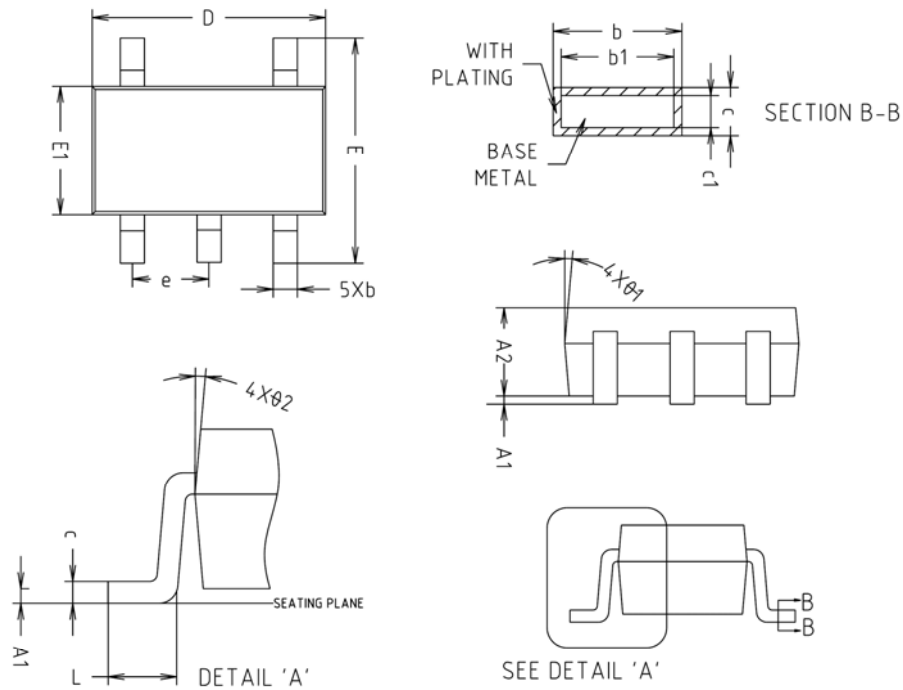

SYMBOL	MILLIMETERS			NOTE
	MINIMUM	NOMINAL	MAXIMUM	
A1	0.000	0.050	0.100	
A2	1.000	1.100	1.200	
b	-	0.400	0.450	
b1	-	0.375	0.425	
c	0.110	0.150	0.190	
c1	0.085	0.125	0.165	
D	2.800	2.900	3.000	
E	2.600	2.800	3.000	
E1	1.500	1.600	1.700	
e	0.930	0.950	0.970	
L	0.400	-	-	
Ø1	5° REF			
Ø2	5° REF			

※ Recommend PCB solder land (Unit : mm)

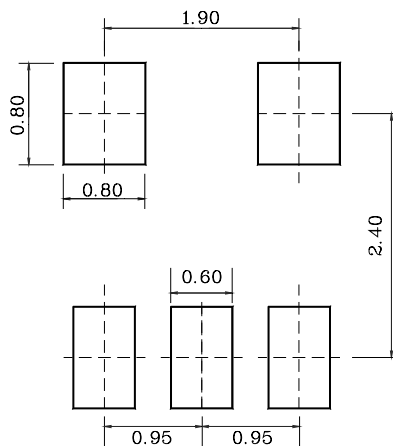

The AUK Corp. products are intended for the use as components in general electronic equipment (Office and communication equipment, measuring equipment, home appliance, etc.).

Please make sure that you consult with us before you use these AUK Corp. products in equipments which require high quality and / or reliability, and in equipments which could have major impact to the welfare of human life(atomic energy control, airplane, spaceship, transportation, combustion control, all types of safety device, etc.). AUK Corp. cannot accept liability to any damage which may occur in case these AUK Corp. products were used in the mentioned equipments without prior consultation with AUK Corp..

Specifications mentioned in this publication are subject to change without notice.