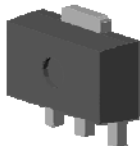

TO-92

SOT-89

ORDERING INFORMATION

Product	Marking	Package
SN317L	N317L	TO-92
SN317LF	N317L	SOT-89

▲ Marking Detail Information



- ① Device Code
- ② Grade & Year & Week Code

Description

The SN317Lx is an adjustable 3-terminal positive voltage regulator capable of supplying in excess of 100mA over an output voltage range of 1.2 V to 37 V. This voltage regulator is exceptionally easy to use and requires only two external resistors to set the output voltage. Further, it employs internal current limiting, thermal shutdown and safe area compensation, making it essentially blow-out proof.

This device can also be used to make a programmable output regulator, or by connecting a fixed resistor between the adjustment and output, the SN317Lx can be used as a precision current regulator.

Application

- ◆ Consumer and personal electronics
- ◆ SMPS post-regulator / dc-to-dc modules
- ◆ High-efficiency linear power supplies
- ◆ LED Light Constant Current Controllers

Features and Benefits

- ◆ Output Current up to 100mA
- ◆ Output Adjustable Level : 1.2V to 37V
- ◆ Built in OVP, CLP circuit.
- ◆ Built in TSD Protection.
- ◆ Output Transistor Safe Area Protection.
- ◆ Ultra High level of ESD [Built in ESD Protection Cell]

Equivalent Circuit

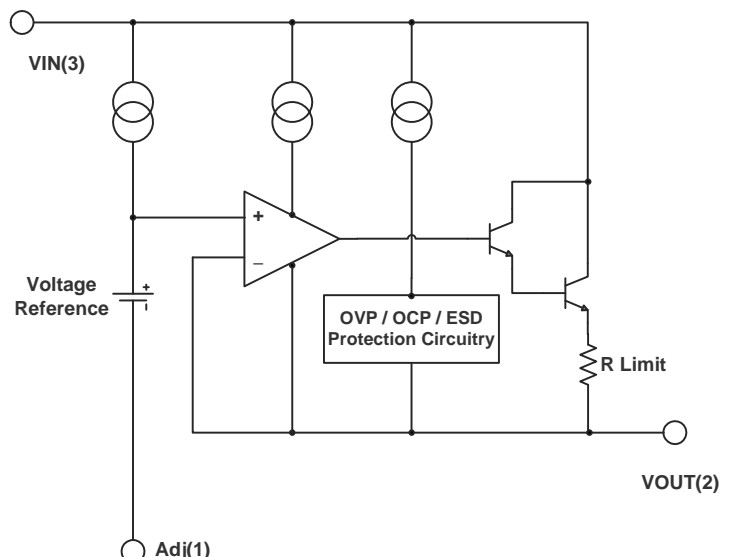

◆ Pin Configuration



◆ Standard Application

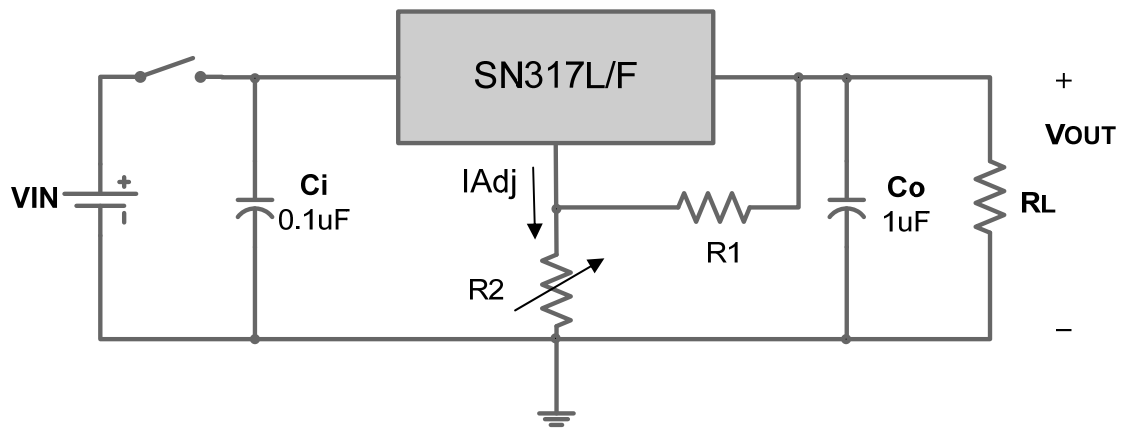

C_i is required if regulator is located an appreciable distance from power supply filter.

C_o is not needed for stability, however, it is necessary to improve transient response.

Since I_{Adj} is controlled to less than 0.1mA, the error associated with this term is insignificant in most applications.

$$V_{OUT} = V_{ref(1.25V)} \times (1 + R_2/R_1) + I_{adj}R_2$$

◆ **Absolute Maximum Ratings (Ta = 25°C)**

Parameter		Symbol	Limits	Unit
Input-Output Voltage Differential		V_I-V_O	40	V
Power Dissipation	TO-92	P_d	Internally Limited	mW
	SOT-89			
Junction Temperature		T_J	150	°C
Operate Temperature Range		T_{opr}	0 ~ +125	°C
Storage Temperature Range		T_{stg}	-55 ~ +150	°C

Stresses exceeding Maximum Ratings may damage the device. Maximum Ratings are stress ratings only. Functional operation above the recommended operating conditions is not implied. Extended exposure to Stresses above the Recommended Operating Conditions may affect device reliability.

The maximum allowable power dissipation is a function of the maximum junction temperature, $T_{J(max)}$, the junction-to-ambient thermal resistance, θ_{JA} , and the ambient temperature, T_A .

The maximum allowable power dissipation at any ambient temperature is calculated using:

$PD(max) = (T_{J(max)} - T_A) \div \theta_{JA}$. Exceeding the maximum allowable power dissipation will result in excessive die temperature, and the regulator will go into thermal shutdown.

◆ Electrical characteristics

($V_I - V_O = 5V$, $I_O = 40mA$, $T_J = 0^\circ C \sim 125^\circ C$, $P_{D_{MAX}} = 625mW$; unless otherwise specified)

Characteristic	Symbol	Test Condition*		SN317Lx			Unit
				Min.	Typ.	Max.	
Line Regulation *	$\Delta V_{O(\text{Line})}$	$3.0V \leq V_I - V_O \leq 40V$	$T_A = +25^\circ C$	-	0.01	0.04	% / V
		$3.0V \leq V_I - V_O \leq 40V$	$T_A = 0 \sim +125^\circ C$	-	0.02	0.07	
Load Regulation *	$\Delta V_{O(\text{Load})}$	$10mA \leq I_O \leq 100mA$ $T_A = +25^\circ C$	$V_O < 5V$ $V_O \geq 5V$	-	5.0 0.1	25.0 0.5	mV % / V_O
		$10mA \leq I_O \leq 100mA$ $T_A = 0 \sim +125^\circ C$	$V_O < 5V$ $V_O \geq 5V$	-	20.0 0.3	70.0 1.5	mV % / V_O
Adjustable Pin Current	I_{ADJ}	-		-	50	100	μA
Adjustable Pin Current Change	ΔI_{ADJ}	$3.0V \leq V_I - V_O \leq 40V$ $10mA \leq I_O \leq 100mA$, $P_D \leq P_{D_{MAX}}$		-	2.0	5.0	μA
Reference Voltage	V_{REF}	$3.0V \leq V_I - V_O \leq 40V$ $10mA \leq I_O \leq I_{MAX}$, $P_D \leq P_{D_{MAX}}$		1.20	1.25	1.30	V
Temperature Stability	ST_T	$0^\circ C \leq T_J \leq 125^\circ C$		-	1.0	-	% / V_O
Ripple Rejection	RR	$V_O = 10V$, $f = 120Hz$ without C_{ADJ}		-	65.0	-	dB
		$V_O = 10V$, $f = 120Hz$, $C_{ADJ} = 10\mu F$ **		-	80.0	-	
Output Noise Voltage	V_{NO}	$10Hz \leq f \leq 100kHz$	$T_A = 25^\circ C$	-	0.003	-	%
Minimum Load Current to Maintain Regulation	$I_{L(\text{MIN})}$	$V_I - V_O = 40V$		-	3.5	10.0	mA
Maximum Output Current	$I_{O(\text{MAX})}$	$V_I - V_O \leq 15V$, $P_D \leq P_{MAX}$	$T_A = 25^\circ C$	100	200	-	mA
		$V_I - V_O \leq 40V$, $P_D \leq P_{MAX}$		25	50	-	
Long-Term Stability	ST	$T_A = +25^\circ C$ for end point measurements, 1000HR		-	0.3	-	%

* Load and line regulation are specified at constant temperature. Change in V_O due to heating effects must be taken into account separately.

** C_{ADJ} is connected between the adjustable pin and ground.

Fig.1 Adjustable Pin Current vs. Junction Temperature

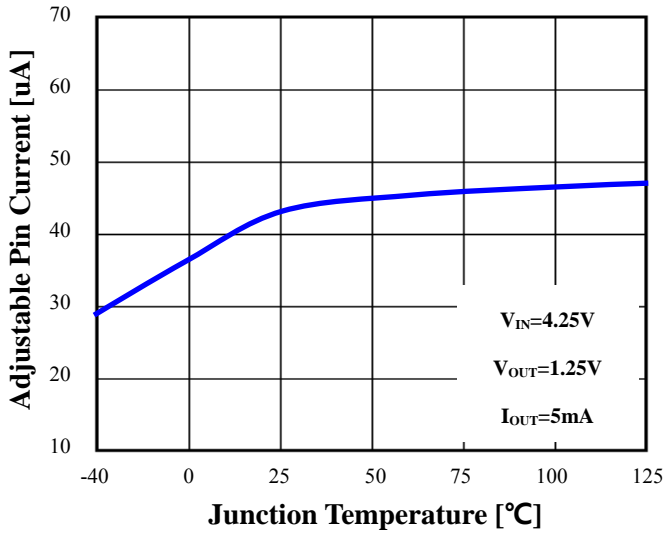

Fig.2 Output Peak Current vs. Input to Output Differential

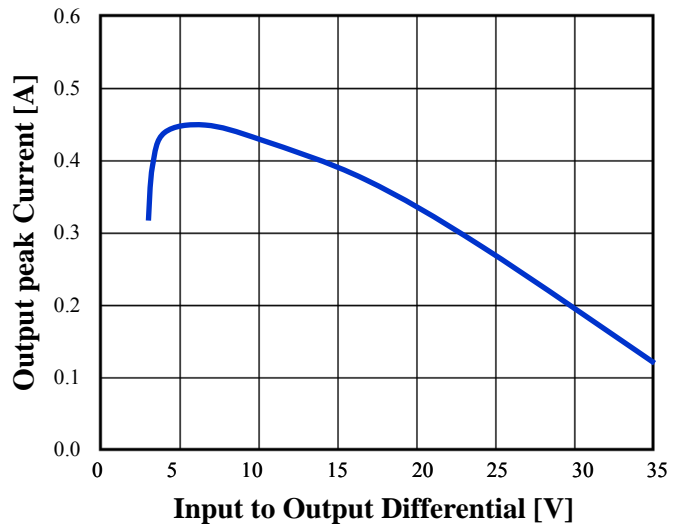

Fig.3 Output Voltage vs. Junction Temperature

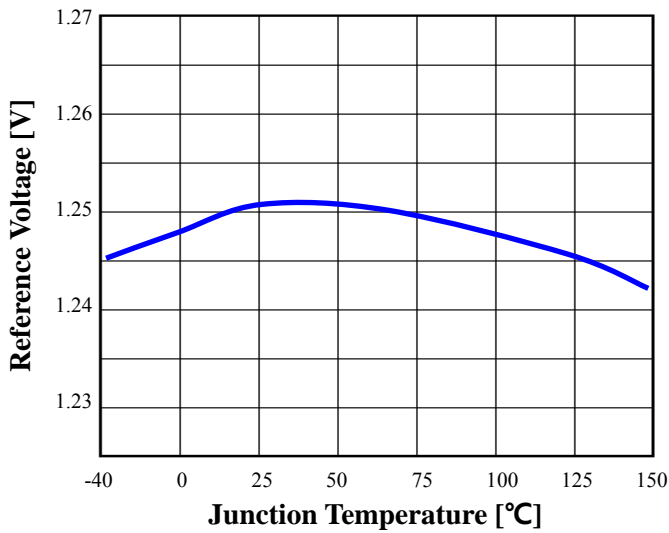

Fig.4 Dropout Voltage vs. Input Voltage

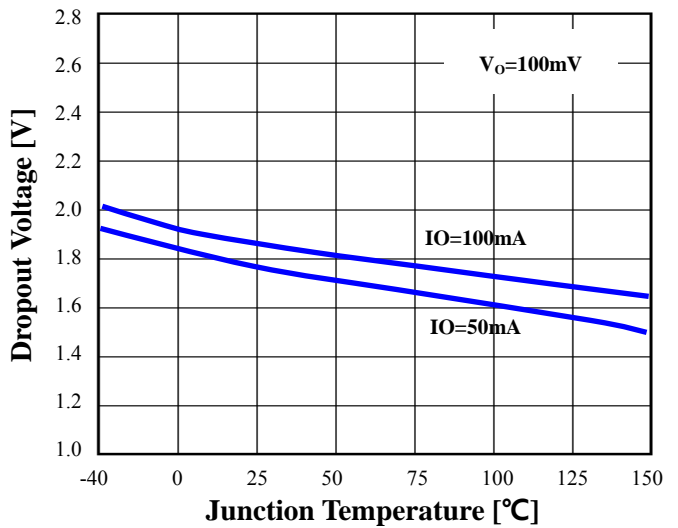

Fig.5 Line Transient Response

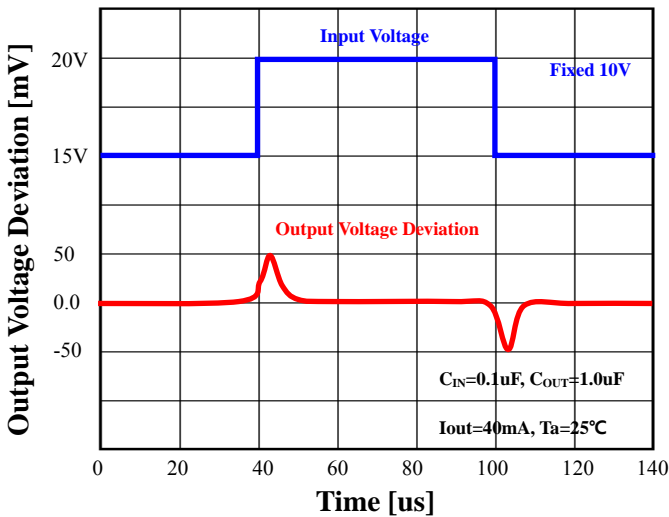
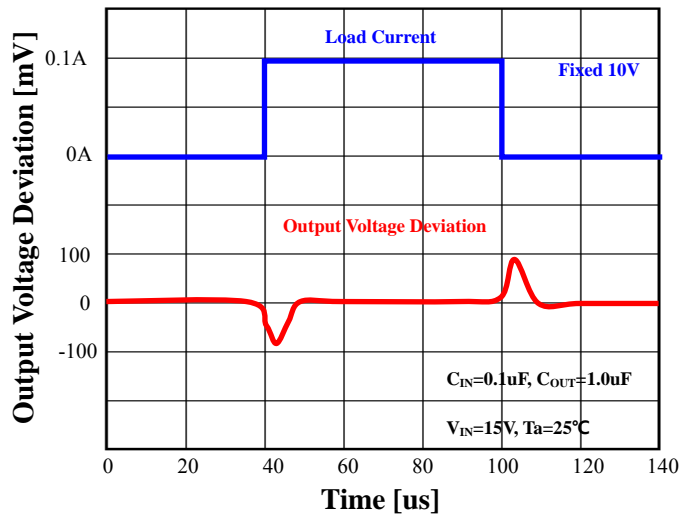
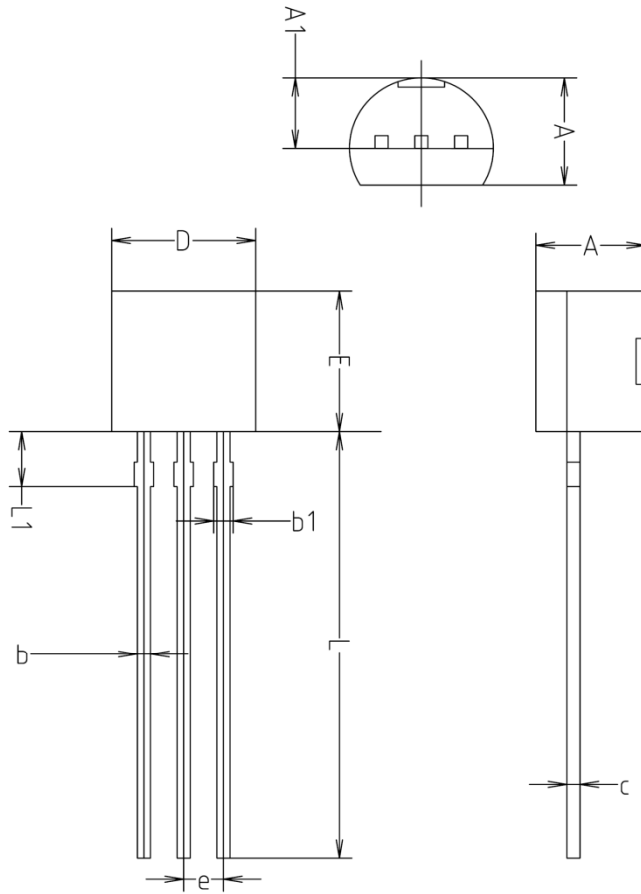

Fig.6 Load Transient Response



◆ **TO-92 Outline Dimension** (Unit : mm)



SYMBOL	MILLIMETERS(mm)		
	MINIMUM	NOMINAL	MAXIMUM
A	3.40	3.50	3.66
A1	2.46	2.51	2.59
b	0.39	0.44	0.53
b1	0.39	—	0.63
c	0.35	0.42	0.47
D	4.48	4.60	4.70
E	4.48	4.60	4.70
e	1.17	1.27	1.37
L	13.70	14.00	14.77
L1	1.55	1.70	2.15

◆ SOT-89 Outline Dimension (Unit : mm)

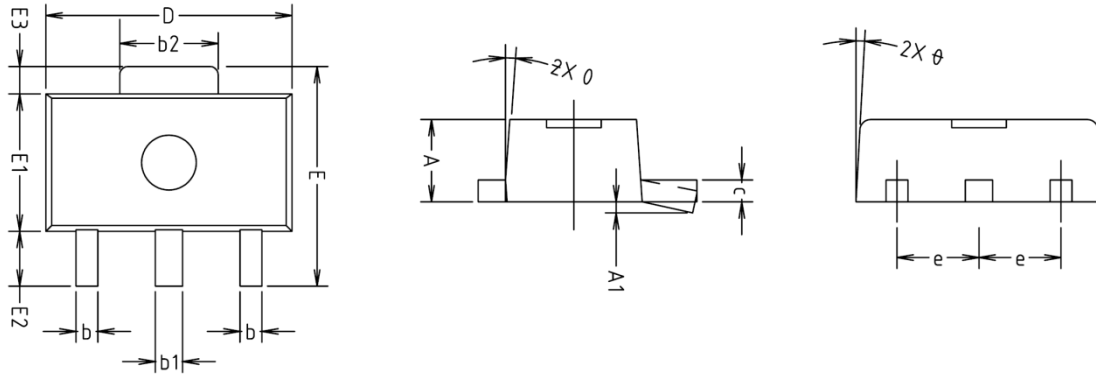

SYMBOL	MILLIMETERS			NOTE
	MINIMUM	NOMINAL	MAXIMUM	
A	1.40	1.50	1.60	
A1	0.00	-	0.10	
b	0.38	0.42	0.48	
b1	0.48	0.52	0.58	
b2	1.79	1.82	1.87	
c	0.40	0.42	0.46	
D	4.40	4.50	4.70	
E	3.70	4.00	4.30	
E1	2.40	2.50	2.70	
E2	0.80	1.00	1.20	
E3	0.40	0.50	0.60	
e	1.50 TYP.			
θ	4° TYP.			

※ Recommend PCB solder land [Unit: mm]

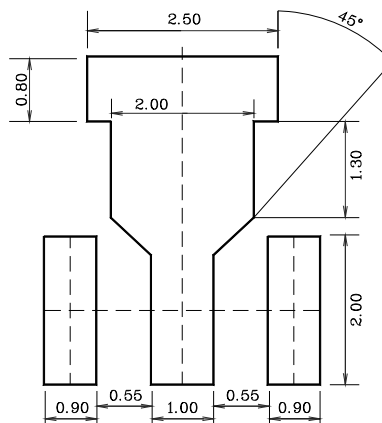

The AUK Corp. products are intended for the use as components in general electronic equipment (Office and communication equipment, measuring equipment, home appliance, etc.).

Please make sure that you consult with us before you use these AUK Corp. products in equipments which require high quality and / or reliability, and in equipments which could have major impact to the welfare of human life(atomic energy control, airplane, spaceship, transportation, combustion control, all types of safety device, etc.). AUK Corp. cannot accept liability to any damage which may occur in case these AUK Corp. products were used in the mentioned equipments without prior consultation with AUK Corp..

Specifications mentioned in this publication are subject to change without notice.