

SG276

The SG276 photointerrupter high-performance standard type, combines high-output GaAs IRED with high sensitive phototransistor

FEATURES

- PWB direct mount type
- GAP : 3.3mm
- With the installation positioning boss
- Compact

APPLICATIONS

- VTR
- Cassette mecha
- Car stereo
- Printers

DIMENSIONS

(Unit : mm)

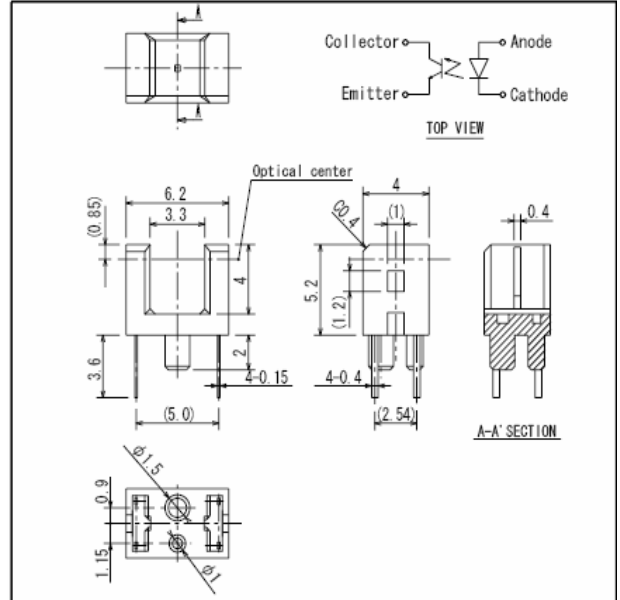

MAXIMUM RATINGS

(Ta=25°C)

Item		Symbol	Rating	Unit
Input	Power dissipation	P_D	75	mW
	Forward current	I_F	50	mA
	Reverse voltage	V_R	5	V
	Pulse forward current *1	I_{FP}	0.5	A
Output	Collector power dissipation	P_C	75	mW
	Collector current	I_C	20	mA
	Collector-Emitter voltage	V_{CEO}	30	V
	Emitter-Collector voltage	V_{ECO}	5	V
Operating temp. *2		$T_{opr.}$	-20 ~ +85	°C
Storage temp. *2		$T_{stg.}$	-30 ~ +85	°C
Soldering temp. *3		$T_{sol.}$	260	°C

*1. Pulse width : $t_w \leq 100\mu s$, period $T=10ms$

*2. No icebound or dew *3. For MAX. 5 seconds at the position of 1mm from the resin edge.

ELECTRO-OPTICAL CHARACTERISTICS

(Ta=25°C)

Item		Symbol	Conditions	Min.	Typ.	Max.	Unit.
Input	Forward voltage	V_F	$I_F=20mA$	-	1.2	1.4	V
	Reverse current	I_R	$V_R=5V$	-	-	10	μA
	Peak wavelength	λ_p	$I_F=20mA$	-	940	-	nm
Output	Collector dark current	I_{CEO}	$V_{CE}=10V, 0lx$	-	1	100	nA
Transmission	Light current	I_C	$I_F=20mA, V_{CE}=5V$ (Non-Shading)	0.2	-	5	mA
	Leakage current	I_{CEOD}	$I_F=20mA, V_{CE}=5V$ (Shading)	-	0.5	10	μA
	C-E saturation voltage	$V_{CE(sat)}$	$I_F=20mA, I_C=0.05mA$	-	0.15	0.4	V
Rise time		t_r	$V_{CC}=5V, I_C=0.1mA, R_L=1k\Omega$	-	50	-	μs
Fall time		t_f		-	50	-	μs

SG276

Collector power dissipation Vs. Ambient temperature

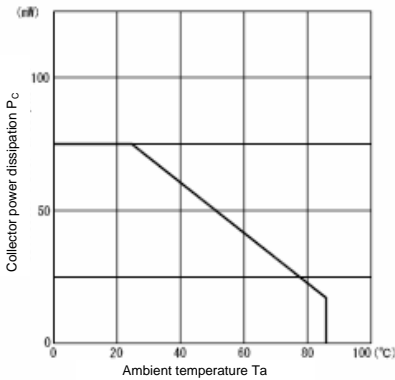

Forward current Vs. Forward voltage

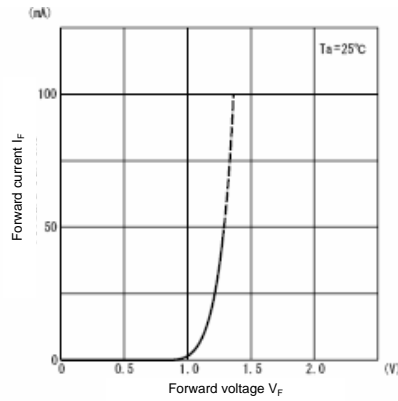

Light current Vs. Forward current

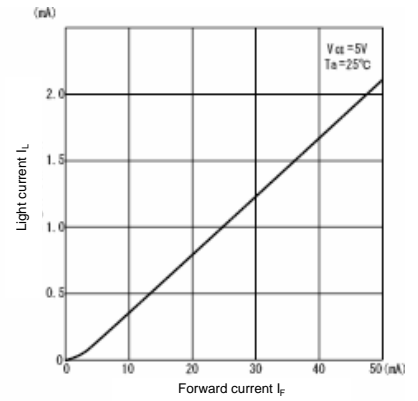

Light current Vs. Collector-Emitter voltage

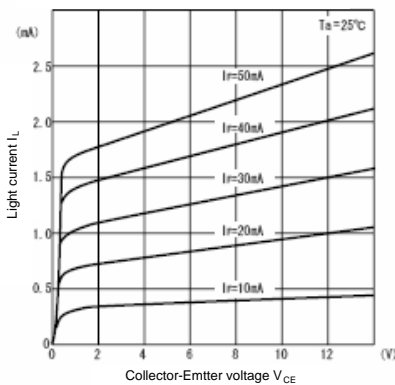

Relative light current Vs. Ambient temperature

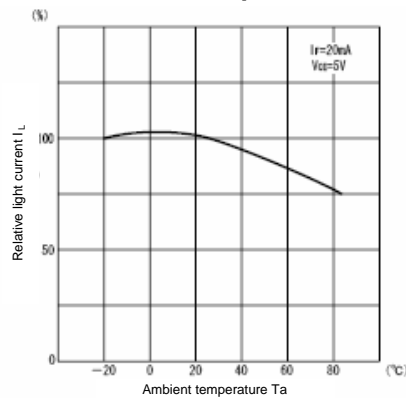

Dark current Vs. Ambient temperature

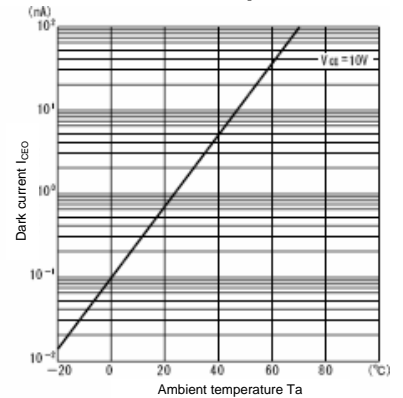

Switching time Vs. Load resistance *1

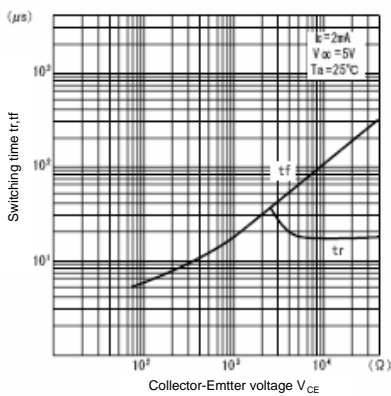

Relative light current Vs. Moving distance *2

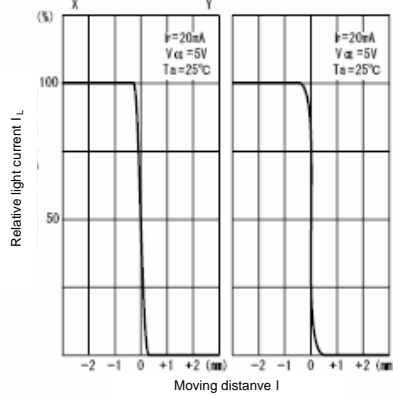

*1 Switching time measurement circuit

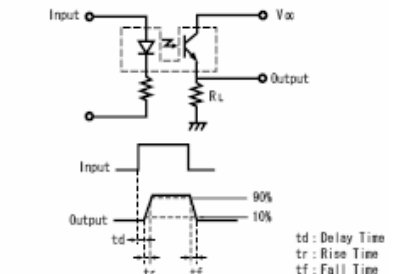

*2 Method of measuring position detection characteristic

