

200V, 10A ULTRAFAST DUAL RECTIFIERS

Features

- Low forward voltage drop and leakage current
- Ultrafast reverse recovery time ($t_{rr} < 30\text{ns}$)
- Low power loss and high efficiency
- Dual common anode rectifier construction
- Full lead (Pb)-free and RoHS compliant device

Applications

- Switching power supply
- Power inverters
- Free-wheeling diode
- Power conversion system
- Motor drives

Description

The SF10A200HPR is an ultrafast rectifier. It has a low forward voltage drop and reverse recovery time ($t_{rr} < 30\text{ns}$). The device is intended for use as a free wheeling, clamping rectifier in a variety of switching power supplies and other power switching applications.

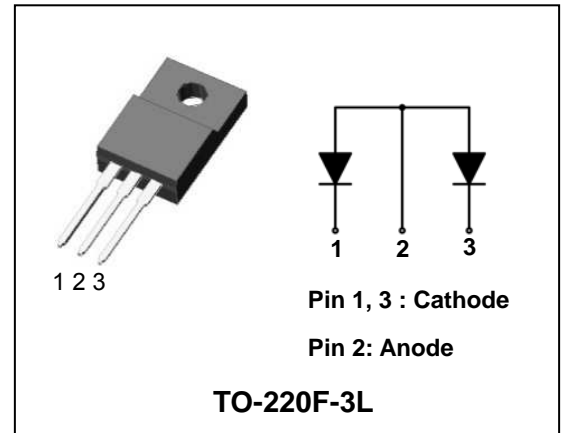

Product Characteristics

| | |
|-------------------|--------|
| $I_{F(AV)}$ | 2 X 5A |
| V_{RRM} | 200V |
| V_{FM} at 125°C | 0.83V |
| t_{rr} | 30ns |

Ordering Information

| Device | Marking Code | Package | Packaging |
|-------------|--------------|------------|-----------|
| SF10A200HPR | SF10A200HPR | TO-220F-3L | Tube |

Marking Information

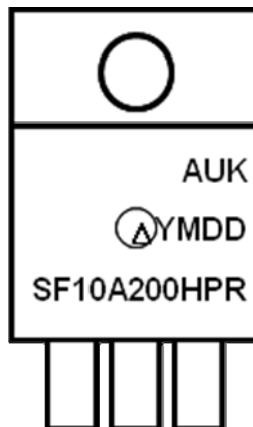

AUK = Manufacture Logo

Δ = Control Code of Manufacture

YMDD = Date Code Marking

- . Y = Year Code

- . M = Monthly Code

- . DD = Daily Code

SF10A200HPR = Specific Device Code

Absolute Maximum Ratings (Limiting Values)

| Characteristic | | Symbol | Value | Unit |
|---|--------------|---------------------------------|-----------------|------|
| Maximum repetitive reverse voltage Maximum working peak reverse voltage Maximum DC blocking voltage | | V_{RRM} V_{RWM} V_R | 200 | V |
| Maximum average forward rectified current | per diode | $I_{F(AV)}$ | 5 | A |
| | total device | | 10 | |
| Peak forward surge current 8.3ms single half sine-wave superimposed on rated load per diode | | I_{FSM} | 100 | A |
| Storage temperature range | | T_{stg} | -45°C to +150°C | °C |
| Maximum operating junction temperature | | T_j | 150 | °C |

Thermal Characteristics

| Characteristic | | Symbol | Value | Unit |
|---|--------------|---------------|-------|------|
| Maximum thermal resistance junction to case | per diode | $R_{th(j-c)}$ | 4 | °C/W |
| | total device | | 3.5 | |

Electrical Characteristics

| Characteristic | Symbol | Test Condition | Min. | Typ. | Max. | Unit | |
|---------------------------|----------------|-------------------------------|-------------------|------|------|------|----|
| Peak forward voltage drop | $V_{FM}^{(1)}$ | $I_{FM} = 5A$ | $T_j=25^\circ C$ | - | - | 0.98 | V |
| | | | $T_j=125^\circ C$ | - | - | 0.83 | V |
| Reverse leakage current | $I_{RM}^{(1)}$ | $V_R = V_{RRM}$ | $T_j=25^\circ C$ | - | - | 10 | uA |
| | | | $T_j=125^\circ C$ | - | - | 200 | uA |
| Reverse recovery time | t_{rr} | $I_F = 1A, di/dt = -100 A/us$ | - | - | 30 | ns | |
| Junction capacitance | C_j | $V_R = 5V_{DC}, f=1MHz$ | - | 50 | - | pF | |

Note : (1) Pulse test : $t_p \leq 380 \mu s$, Duty cycle $\leq 2\%$

Rating & Electrical Characteristic Curves

Fig. 1) Typical Forward Characteristics (Per diode)

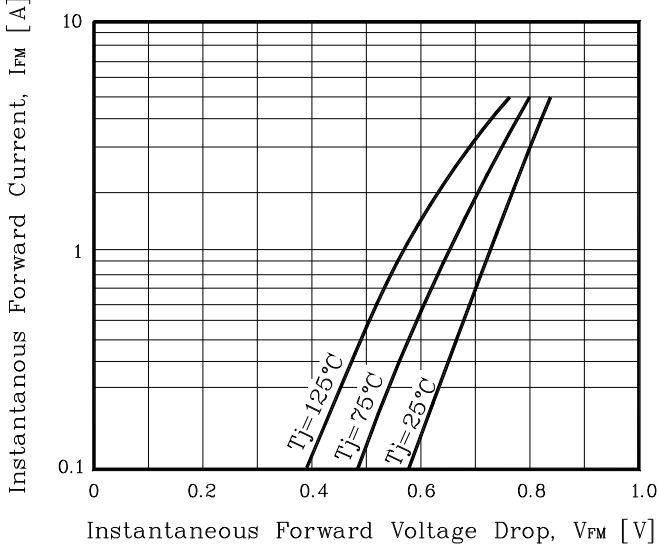

Fig. 2) Typical Reverse Characteristics (Per diode)

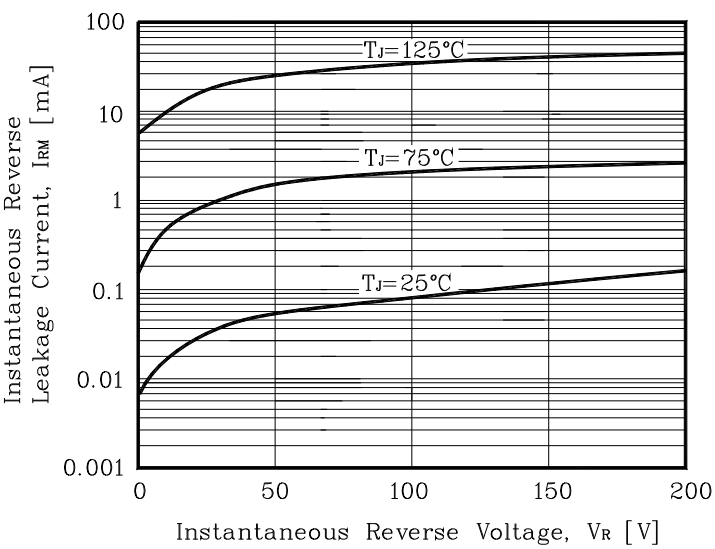

Fig. 3) Maximum Forward Derivative Curve

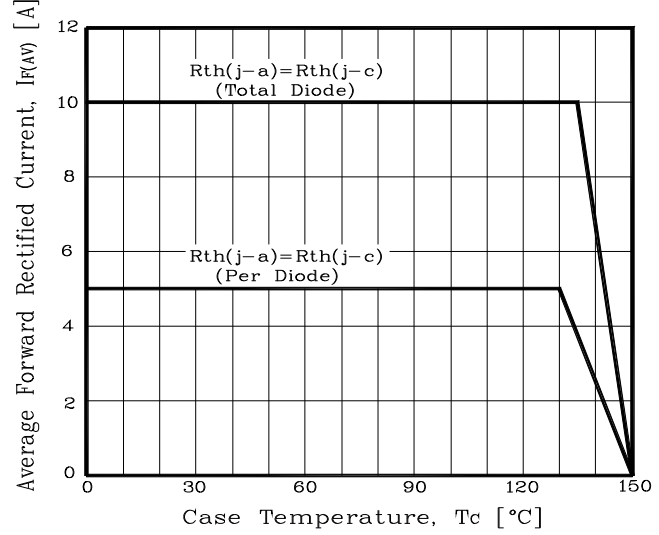

Fig. 4) Forward Power Dissipation (Per diode)

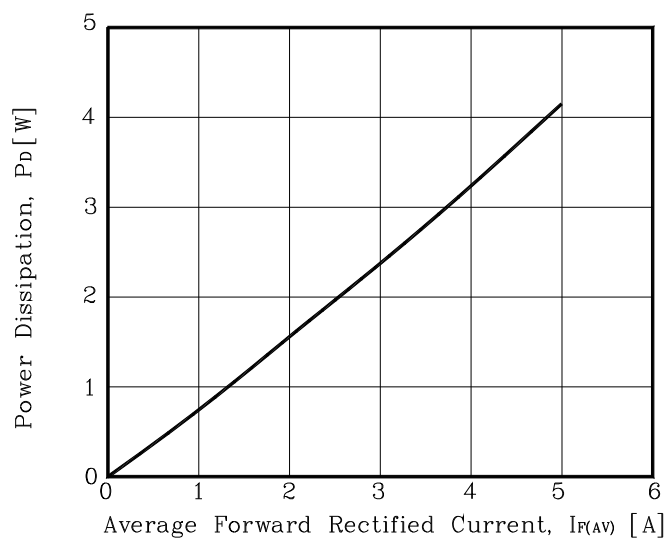

Fig. 5) Maximum Non-Repetitive Peak Forward Surge Current (Per diode)

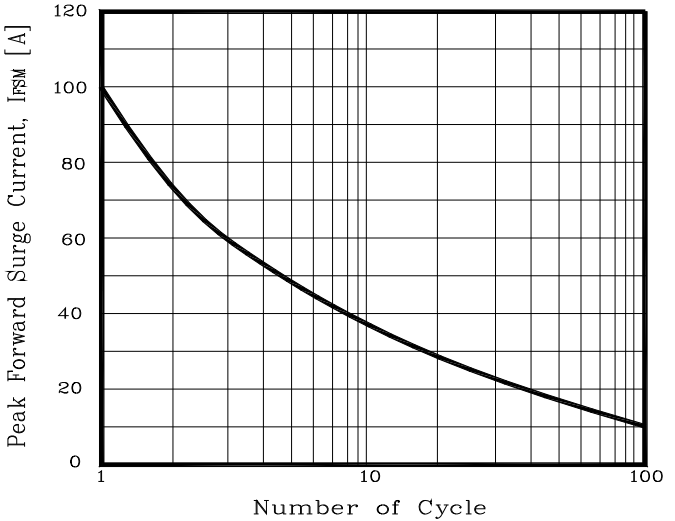
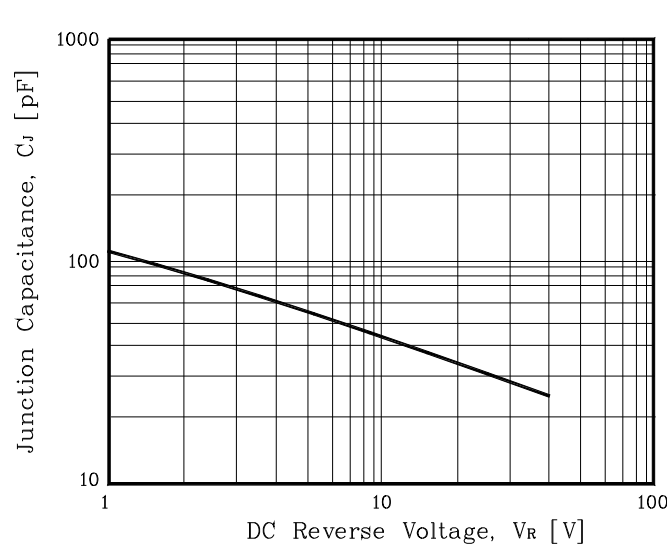
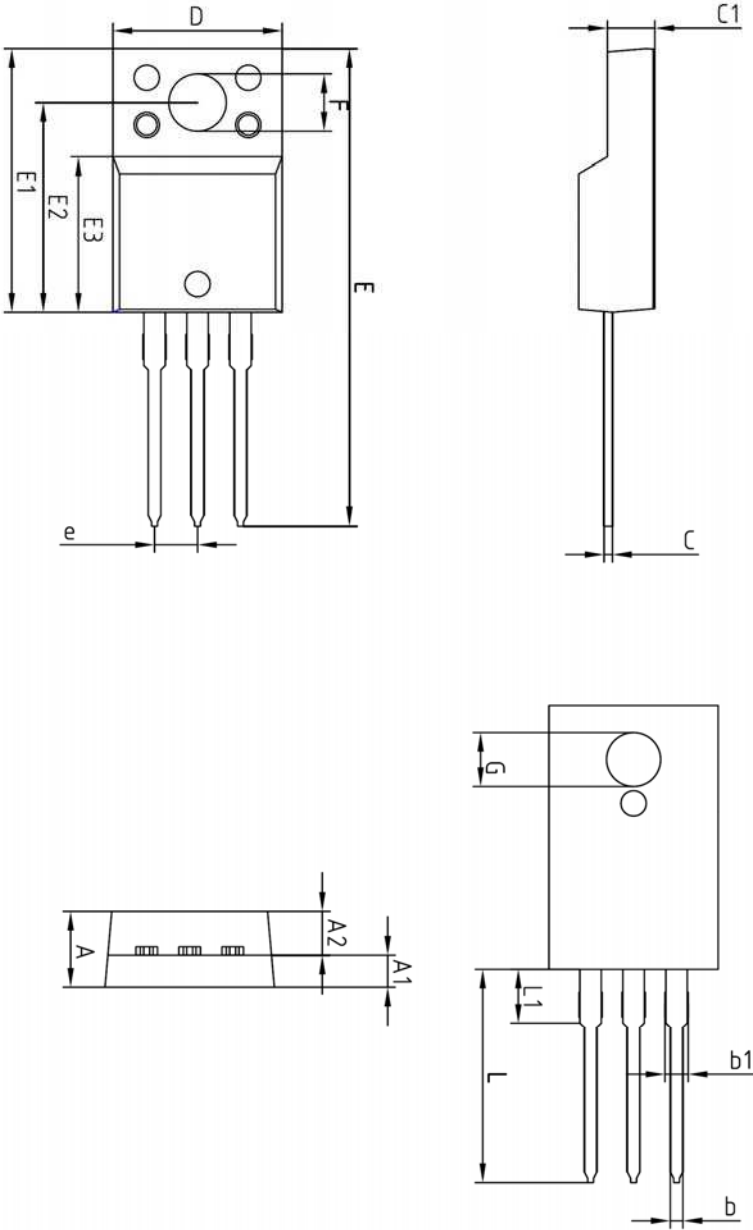

Fig. 6) Typical Junction Capacitance (Per diode)



Package Outline Dimension



| SYMBOL | MILLIMETERS | | | NOTE |
|--------|-------------|---------|---------|------|
| | MINIMUM | NOMINAL | MAXIMUM | |
| A | - | - | 4.60 | |
| A1 | 2.45 | 2.50 | 2.55 | |
| A2 | 1.95 | 2.00 | 2.05 | |
| b | 0.65 | 0.75 | 0.85 | |
| b1 | 1.07 | 1.27 | 1.47 | |
| C | 0.40 | 0.50 | 0.60 | |
| C1 | 2.70 | 2.80 | 2.90 | |
| D | 9.90 | 10.00 | 10.10 | |
| E | 28.00 | - | 28.60 | |
| E1 | 15.50 | 15.60 | 15.70 | |
| E2 | 12.30 | 12.40 | 12.50 | |
| E3 | 9.15 | 9.20 | 9.25 | |
| F | 3.30 | 3.40 | 3.50 | |
| G | 3.10 | 3.20 | 3.30 | |
| e | 2.54 BSC | | | |
| L | 12.40 | - | 13.00 | |
| L1 | 3.46 BSC | | | |

The AUK Corp. products are intended for the use as components in general electronic equipment (Office and communication equipment, measuring equipment, home appliance, etc.).

Please make sure that you consult with us before you use these AUK Corp. products in equipments which require high quality and / or reliability, and in equipments which could have major impact to the welfare of human life(atomic energy control, airplane, spaceship, transportation, combustion control, all types of safety device, etc.). AUK Corp. cannot accept liability to any damage which may occur in case these AUK Corp. products were used in the mentioned equipments without prior consultation with AUK Corp..

Specifications mentioned in this publication are subject to change without notice.