

DUAL COMMON CATHODE SCHOTTKY RECTIFIER

Features

- Low forward voltage drop and leakage current
- Low power loss and High efficiency
- High surge capability
- Dual common cathode rectifier
- Halogen-free component and RoHS compliant device

Applications

- Power supply - Output rectification
- Converter
- Free-wheeling diode
- Reverse battery protection
- Power inverters

Description

The SDB10D150D2 has two schottky barriers arranged in a common cathode configuration. Typical applications are in switching power supplies, converters, free-wheeling diodes, and reverse battery protection.

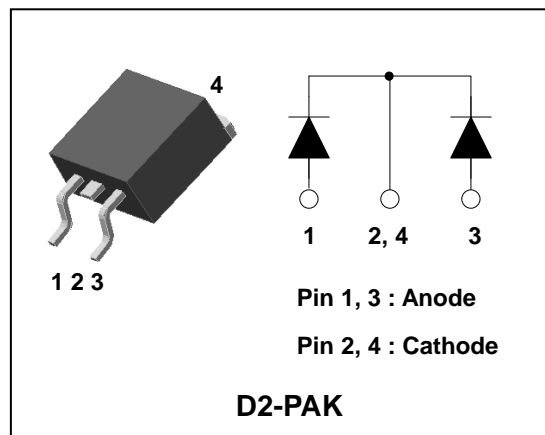

Product Characteristics

| | |
|-------------------|--------|
| $I_{F(AV)}$ | 2 X 5A |
| V_{RRM} | 150V |
| V_{FM} at 125°C | 0.75V |
| I_{FSM} | 120A |

Ordering Information

| Device | Marking Code | Package | Packaging |
|-------------|--------------|---------|-------------|
| SDB10D150D2 | SDB10D150D2 | D2-PAK | Tape & Reel |

Marking Information

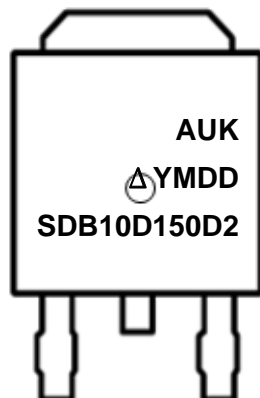

AUK = Manufacture Logo

Δ = Control Code of Manufacture

YMDD = Date Code Marking

-. Y = Year Code

-. M = Monthly Code

-. DD = Daily Code

SDB10D150D2 = Specific Device Code

Absolute Maximum Ratings (Limiting Values)

| Characteristic | Symbol | Value | Unit |
|---|---------------------------------|-----------------|------|
| Maximum repetitive reverse voltage Maximum working peak reverse voltage Maximum DC blocking voltage | V_{RRM} V_{RWM} V_R | 150 | V |
| Maximum average forward rectified current | per diode | 5 | A |
| | total device | 10 | |
| Peak forward surge current 8.3ms single half sine-wave superimposed on rated load per diode | I_{FSM} | 120 | A |
| Storage temperature range | T_{stg} | -45°C to +150°C | °C |
| Maximum operating junction temperature | T_j | 150 | °C |

Thermal Characteristics

| Characteristic | Symbol | Value | Unit |
|---|--------------|-------|------|
| Maximum thermal resistance junction to case | per diode | 3.5 | °C/W |
| | total device | 3.3 | |

Electrical Characteristics (Per Diode)

| Characteristic | Symbol | Test Condition | Min. | Typ. | Max. | Unit | |
|---------------------------|----------------|-------------------------|---------------------|------|------|------|----|
| Peak forward voltage drop | $V_{FM}^{(1)}$ | $I_{FM} = 5A$ | $T_j = 25^\circ C$ | - | - | 0.88 | V |
| | | | $T_j = 125^\circ C$ | - | - | 0.75 | V |
| Reverse leakage current | $I_{RM}^{(1)}$ | $V_R = V_{RRM}$ | $T_j = 25^\circ C$ | - | - | 10 | uA |
| | | | $T_j = 125^\circ C$ | - | - | 10 | mA |
| Junction capacitance | C_j | $V_R = 4V_{DC}, f=1MHz$ | - | 80 | - | pF | |

Note : (1) Pulse test : $t_p \leq 380 \mu s$, Duty cycle $\leq 2\%$

To evaluate the conduction losses use the following equation (Fig 4.) : $P_F = 0.72 \times I_{F(AV)} + 0.021 I_{F(RMS)}^2$

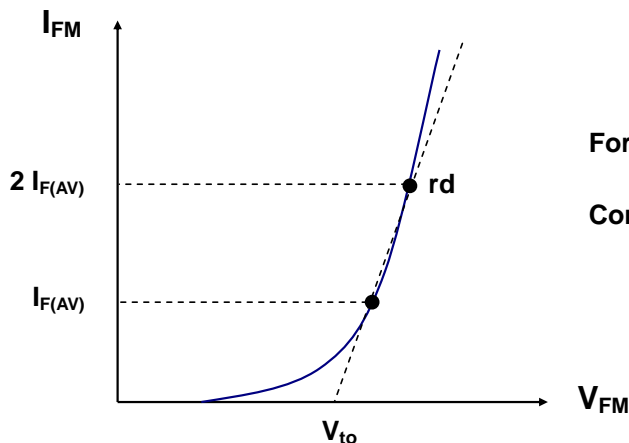

Forward Voltage: $V_{FM} = V_{to} + rd I_{FM}$

Conduction Loss: $P_F = V_{to} I_{F(AV)} + rd I_{F(RMS)}^2$

Rating and Characteristic Curves

Fig. 1) Typical Forward Characteristics (Per diode)

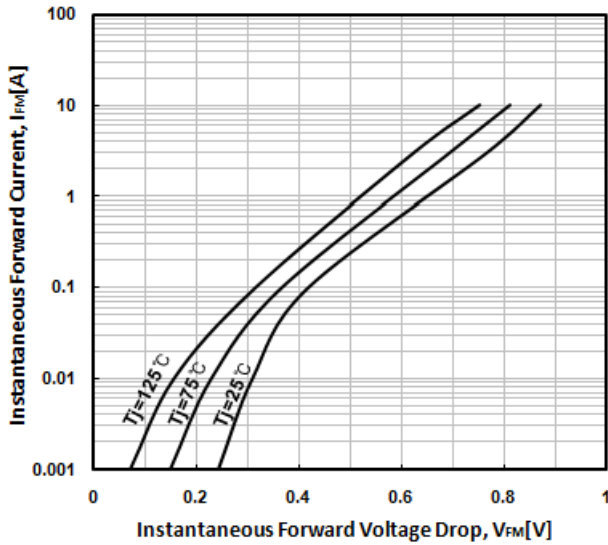

Fig. 2) Typical Reverse Characteristics (Per diode)

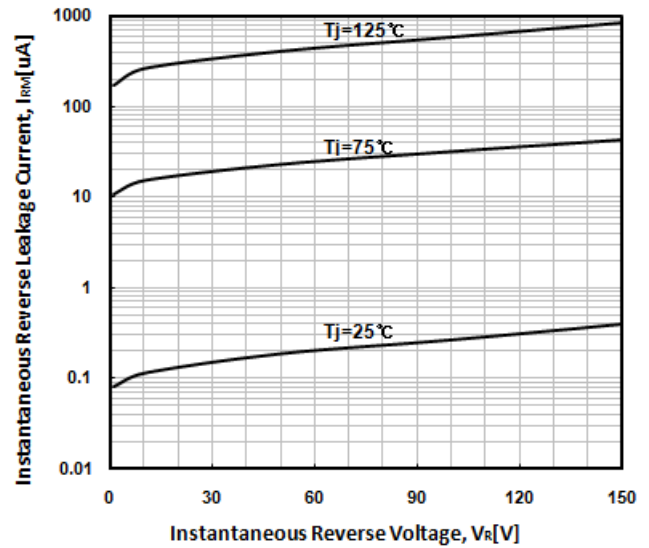

Fig. 3) Maximum Forward Derivative Curve

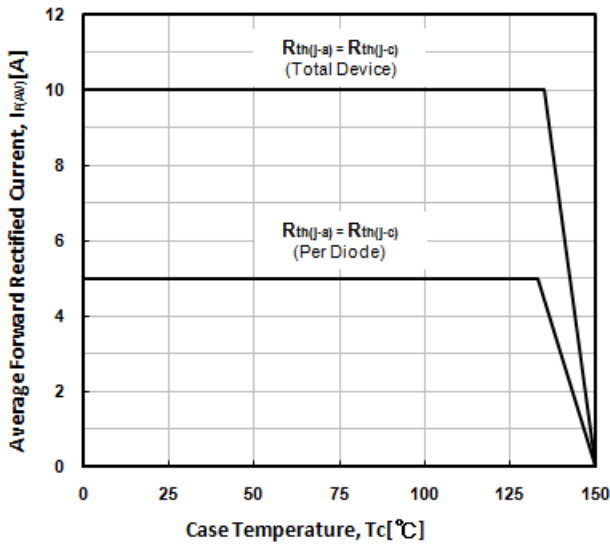

Fig. 4) Forward Power Dissipation (Per diode)

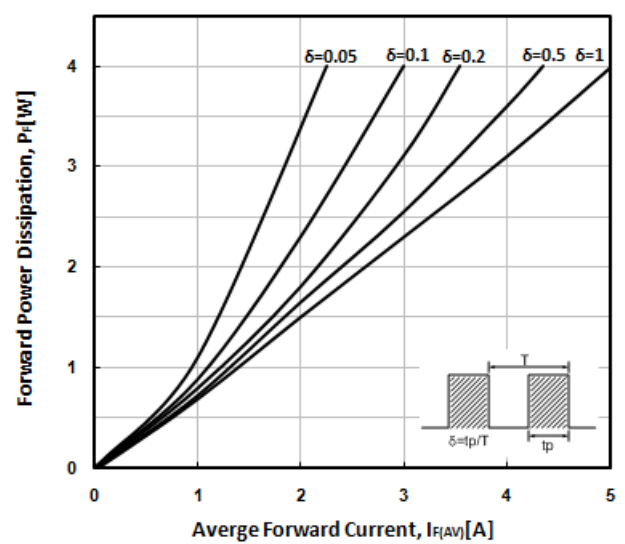

Fig. 5) Maximum Non-Repetitive Peak Forward Surge Current (Per diode)

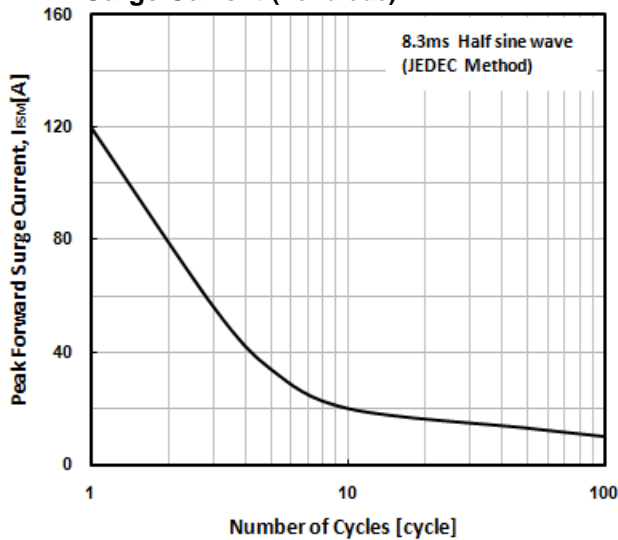
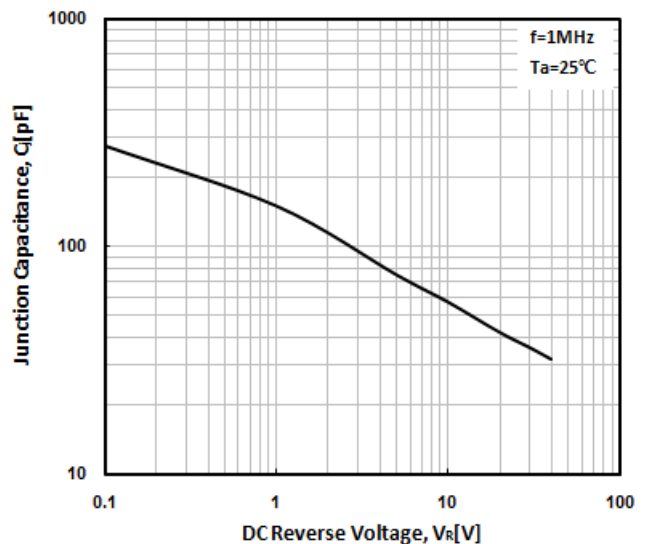
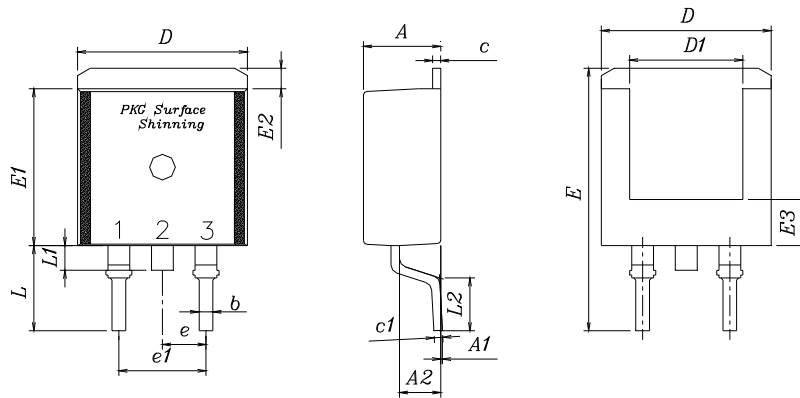

Fig. 6) Typical Junction Capacitance (Per diode)



Package Outline Dimension



| SYMBOL | MILLIMETERS | | | NOTE |
|--------|-------------|---------|---------|------|
| | MINIMUM | NOMINAL | MAXIMUM | |
| A | 4.35 | 4.50 | 4.65 | |
| A1 | — | — | 0.15 | |
| A2 | 2.20 | 2.40 | 2.60 | |
| b | 0.70 | 0.80 | 0.90 | |
| c | 0.40 | 0.50 | 0.60 | |
| c1 | 0.40 | 0.50 | 0.60 | |
| D | 9.80 | 10.00 | 10.20 | |
| D1 | 6.40 | 6.60 | 6.80 | |
| E | 15.00 | 15.40 | 15.80 | |
| E1 | 9.05 | 9.20 | 9.35 | |
| E2 | 1.00 | 1.20 | 1.40 | |
| E3 | 2.50 | 2.70 | 2.90 | |
| e | 2.34 | 2.54 | 2.74 | |
| e1 | 4.88 | 5.08 | 5.28 | |
| L | 4.60 | 5.00 | 5.40 | |
| L1 | 1.40 | 1.45 | 1.50 | |
| L2 | 2.50 | — | — | |

※ Recommended Land Pattern (unit: mm)

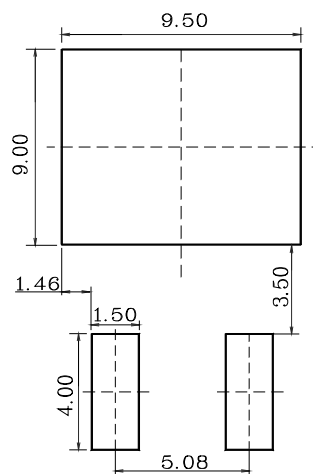

The AUK Corp. products are intended for the use as components in general electronic equipment (Office and communication equipment, measuring equipment, home appliance, etc.).

Please make sure that you consult with us before you use these AUK Corp. products in equipments which require high quality and / or reliability, and in equipments which could have major impact to the welfare of human life(atomic energy control, airplane, spaceship, transportation, combustion control, all types of safety device, etc.). AUK Corp. cannot accept liability to any damage which may occur in case these AUK Corp. products were used in the mentioned equipments without prior consultation with AUK Corp..

Specifications mentioned in this publication are subject to change without notice.