

## 600V, 8A STANDARD TRIAC

This device is suitable for low power AC switching application, phase control application such as fan speed and temperature modulation control, lighting control and static switching relay.

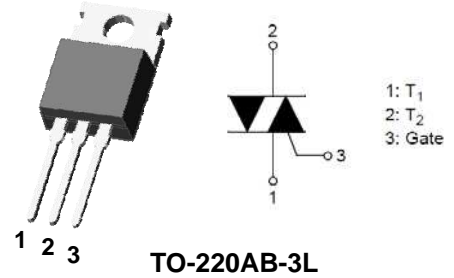

### Features

- Repetitive Peak Off-State Voltage :  $V_{DRM}=600V$
- R.M.S On-State Current :  $I_{T(RMS)}=8A$
- Gate trigger current :  $I_{GT}=40mA$  max (Mode I - II - III)
- High Commutation:  $(di/dt)_C = 11.1 A/ms$  (Min)

### Applications

- Switching mode power supply, light dimmer
- TV sets, stereo, refrigerator, washing machine
- Electric blanket, solenoid driver, small motor control
- Photo copier, electric tool

### Ordering Information

Device	Marking Code	Package	Packaging
<b>SCT08N60P</b>	<b>SCT08N60</b>	<b>TO-220AB-3L</b>	<b>Tube</b>

### Product Characteristics

Symbol	Rating
$I_{T(RMS)}$	8A
$V_{DRM}$	600V

### Marking Diagram

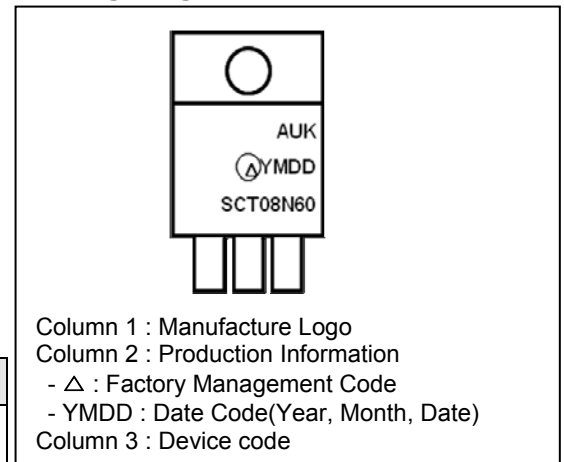

### Absolute Maximum Ratings (Limiting Values)

Characteristic	Symbol	Value	Unit
Repetitive Peak Off-state Voltage	$V_{DRM}$	600	V
RMS on-state current (full sine wave)	$I_{T(RMS)}$	8	A
Non-repetitive surge peak on-state current (full cycle, $T_j$ initial = 25°C)	$I_{TSM}$	84	A
$I^2t$ Value for fusing	$I^2t$	36	A <sup>2</sup> s
Peak gate current	$I_{GM}$	4	A
Peak gate power dissipation	$P_{GM}$	5	W
Average gate peak dissipation	$P_{G(AV)}$	1	W
Storage temperature range	$T_{stg}$	-40 to +150	°C
Operating junction temperature range	$T_j$	-40 to +125	°C

## Thermal Characteristics

Characteristic	Symbol	Value	Unit
Maximum thermal resistance junction to case (AC)	$R_{th(j-c)}$	2.0	$^{\circ}\text{C}/\text{W}$
Maximum thermal resistance junction to ambient (AC)	$R_{th(j-a)}$	60	$^{\circ}\text{C}/\text{W}$

## Electrical Characteristics ( $T_J=25^{\circ}\text{C}$ , unless otherwise specified)

### Off Characteristics

Characteristic	Symbol	Test Condition	Min.	Typ.	Max.	Unit
Repetitive peak Off-state current	$I_{DRM}$	$V_D = V_{DRM}$	-	-	5	$\mu\text{A}$
Repetitive peak reverse current	$I_{RRM}$	$V_R = V_{RRM}$	-	-	5	$\mu\text{A}$

### On Characteristics

Characteristic	Symbol	Test Condition	Min.	Typ.	Max.	Unit
Peak On-state voltage	$V_{TM}$	$I_T = 11\text{A}$	-	-	1.55	V
Holding current	$I_H$	$V_D = 12\text{V}, I_T = 0.2\text{A}$	-	-	50	mA
Gate trigger current	$I_{GT} (I - II - III)$	$V_D = 12\text{V}, R_L = 30\Omega$	-	-	40	mA
	$I_{GT} (IV)$	-	-	-	-	mA
Gate trigger voltage	$V_{GT} (I - II - III)$	$V_D = 12\text{V}, R_L = 30\Omega$	-	-	1.3	V
Gate Non-trigger voltage	$V_{GD}$	$V_D = 2/3 V_{DRM}, T_J = 125^{\circ}\text{C}$	0.2	-	-	V

### Dynamic Characteristics

Characteristic	Symbol	Test Condition	Min.	Typ.	Max.	Unit
Critical rate of rise of Off-state Voltage	$(dV/dt)_S$	$V_D = 2/3 V_{DRM}, T_J = 125^{\circ}\text{C}$	3500	-	-	$\text{V}/\mu\text{s}$
Rate of Change of Commutation Current	$(dI/dt)_C$	$(dV/dt)_C = 10\text{V}/\mu\text{s} \downarrow, T_J = 125^{\circ}\text{C}$	11.1	-	-	$\text{A}/\text{ms}$
Critical rate of rise of on-state current	$dI/dt$	$f = 120\text{Hz}, I_G = 2 \times I_{GT}, t_r \leq 100\text{ns}, T_J = 125^{\circ}\text{C}$	-	-	50	$\text{A}/\mu\text{s}$

Simple circuit for  $(dV/dt)_S$

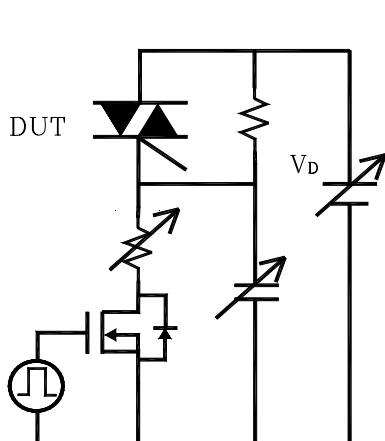

Simple circuit for  $(dI/dt)_C$  vs  $(dV/dt)_C$

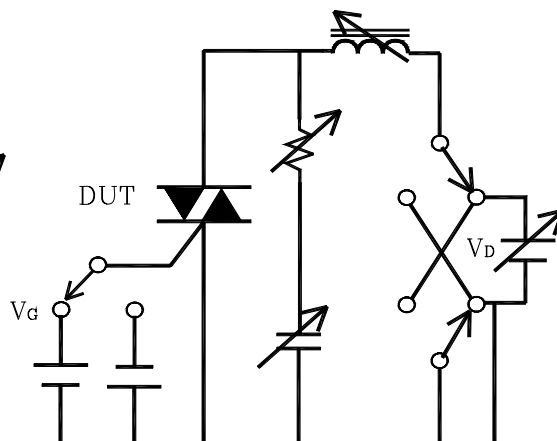

Simple circuit for  $dI/dt$

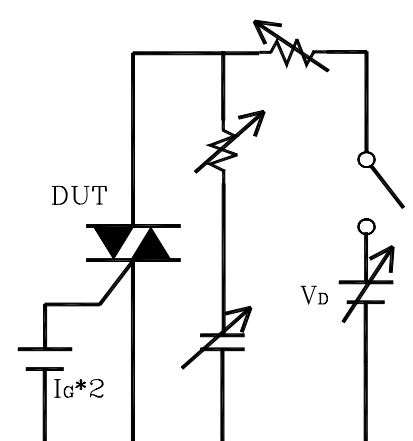

## Electrical Characteristic Curves

**Fig. 1**  $P - I_{T(RMS)}$

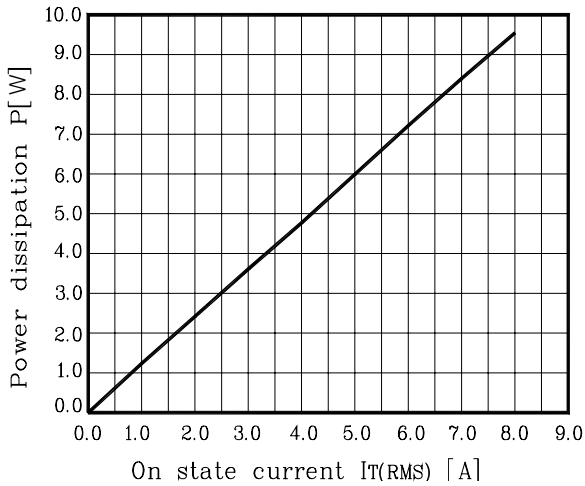

**Fig. 2**  $I_{T(RMS)} - T_c$

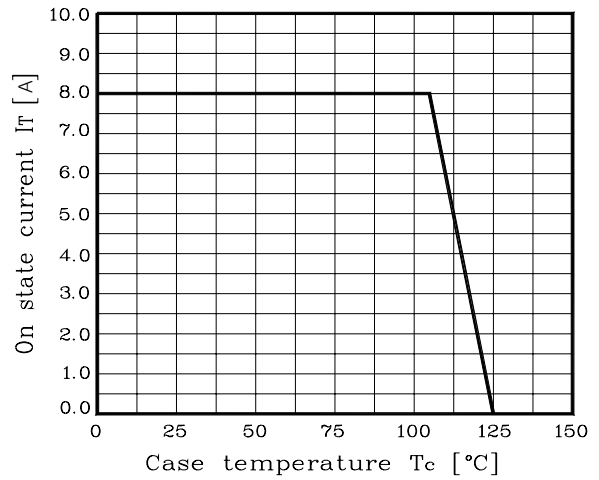

**Fig. 3**  $I_T - V_T$

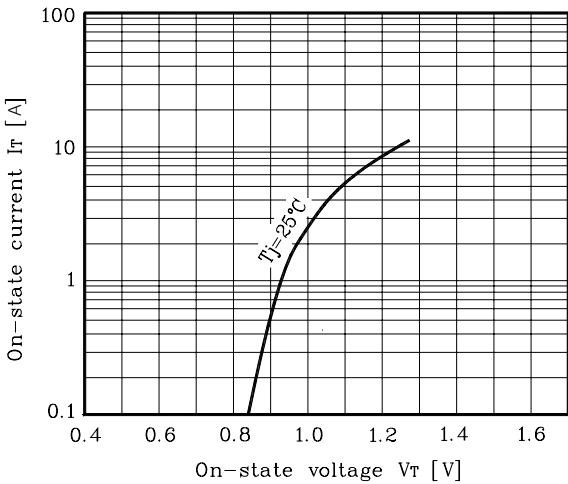

**Fig. 4**  $(di/dt)_c - (dV/dt)_c$

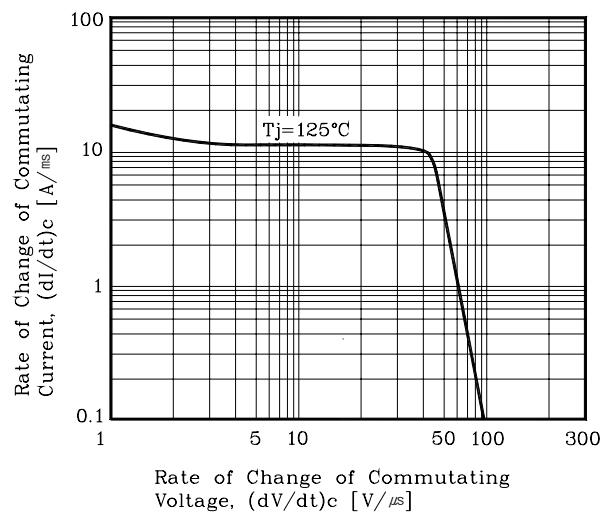

**Fig. 5**  $I_{GT} - T_j$

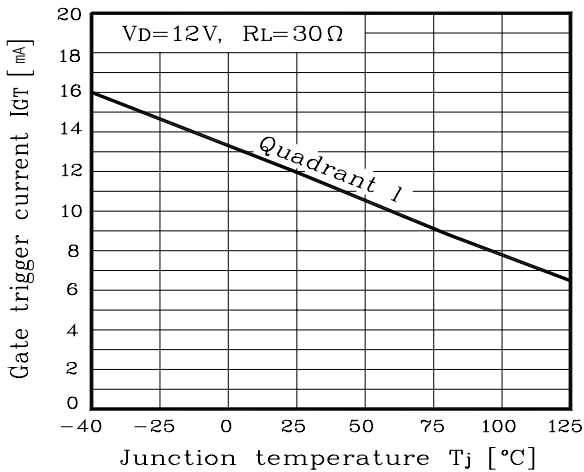

**Fig. 6**  $I_T - I_{GT}$

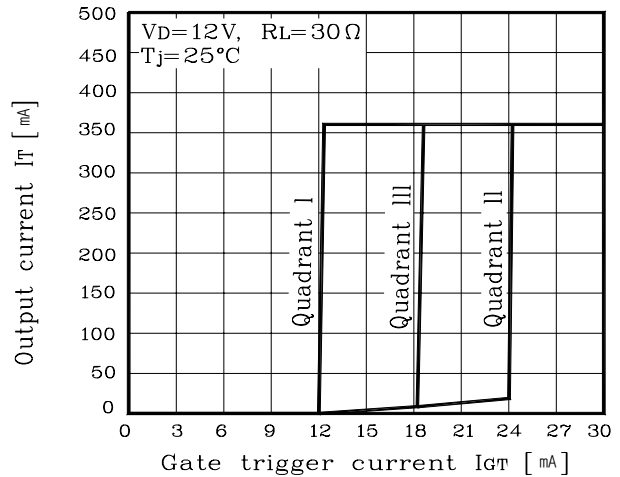

Electrical Characteristic Curves

Fig. 7  $V_{GT} - T_j$

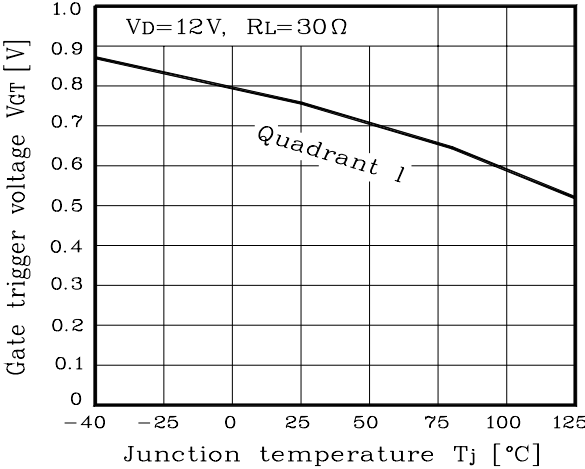

Fig. 8  $I_T - V_{GT}$

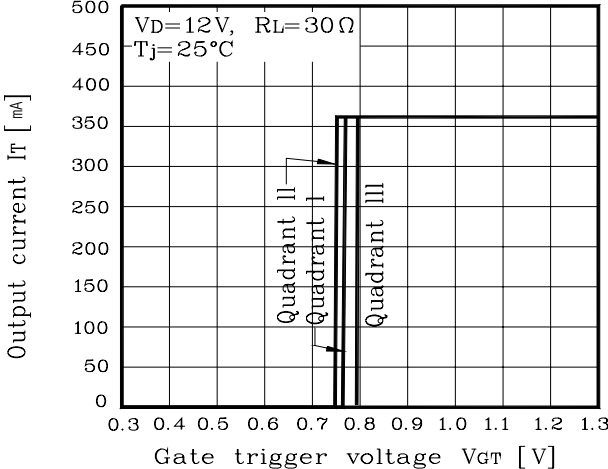
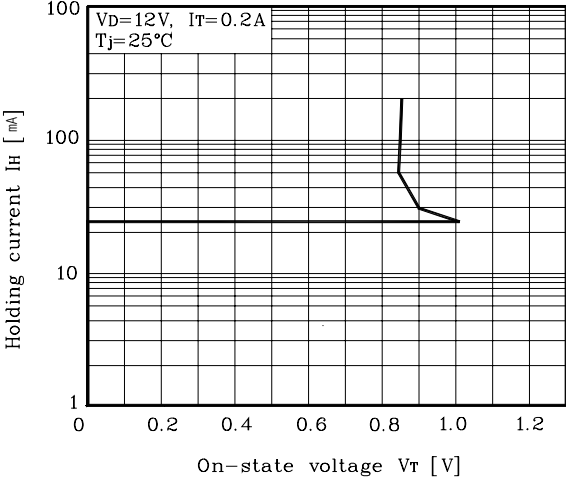
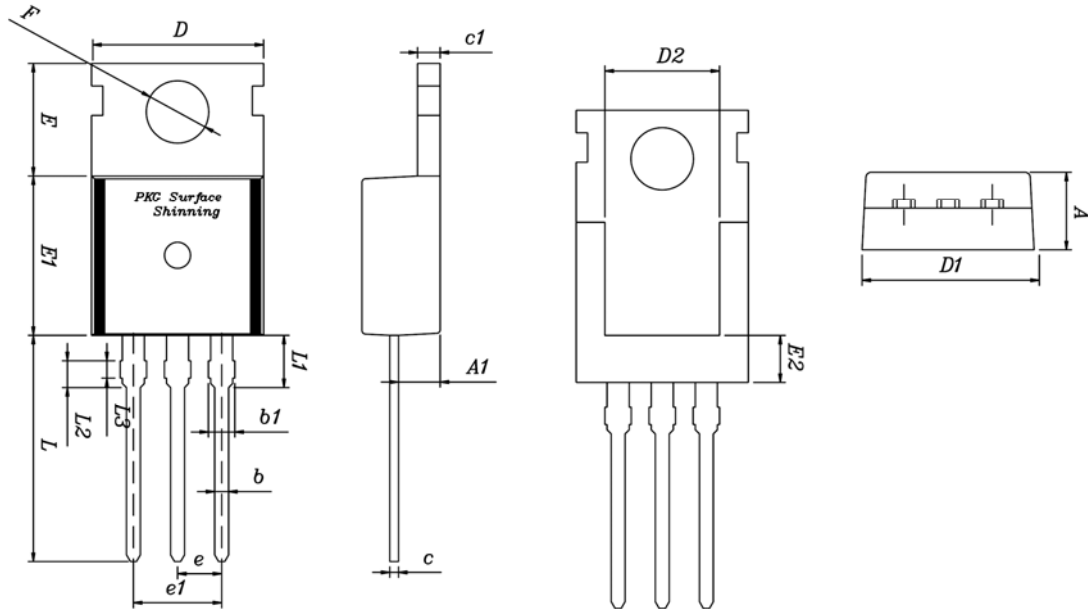

Fig. 9  $I_H - V_T$



## Package Outline Dimension



SYMBOL	MILLIMETERS			NOTE
	MINIMUM	NOMINAL	MAXIMUM	
A	4.35	4.50	4.65	
A1	2.20	2.40	2.60	
b	0.65	0.80	0.95	
b1	1.42	1.52	1.62	
C	0.40	0.50	0.60	
C1	1.20	1.30	1.40	
D	9.80	10.00	10.20	
D1	9.85	10.00	10.15	
D2	6.40	6.60	6.80	
E	6.30	6.50	6.70	
E1	9.05	9.20	9.35	
E2	2.50	2.70	2.90	
F	3.50	3.60	3.70	
e	2.34	2.54	2.64	
e1	4.88	5.08	5.28	
L	12.68	13.08	13.48	
L1	2.80	3.00	3.20	
L2	1.49	1.54	1.59	
L3	0.95	1.00	1.05	

**The AUK Corp. products are intended for the use as components in general electronic equipment (Office and communication equipment, measuring equipment, home appliance, etc.).**

**Please make sure that you consult with us before you use these AUK Corp. products in equipments which require high quality and / or reliability, and in equipments which could have major impact to the welfare of human life(atomic energy control, airplane, spaceship, transportation, combustion control, all types of safety device, etc.). AUK Corp. cannot accept liability to any damage which may occur in case these AUK Corp. products were used in the mentioned equipments without prior consultation with AUK Corp..**

**Specifications mentioned in this publication are subject to change without notice.**