

600V, 4A STANDARD TRIAC

This device is suitable for low power AC switching application, phase control application such as fan speed and temperature modulation control, lighting control and static switching relay.

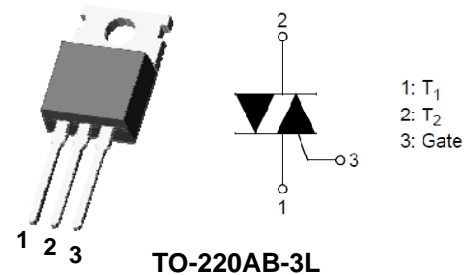

Features

- Repetitive Peak Off-State Voltage : $V_{DRM}=600V$
- R.M.S On-State Current : $I_{T(RMS)}=4A$
- High Commutation: $(di/dt)_C = 2.5A/ms$ (Min)

Product Characteristics

Symbol	Rating
$I_{T(RMS)}$	4A
V_{DRM}	600V

Applications

- Switching mode power supply, light dimmer
- TV sets, stereo, refrigerator, washing machine
- Electric blanket, solenoid driver, small motor control
- Photo copier, electric tool

Ordering Information

Device	Marking Code	Package	Packaging
SCT04N60P	SCT04N60	TO-220AB-3L	Tube

Marking Diagram

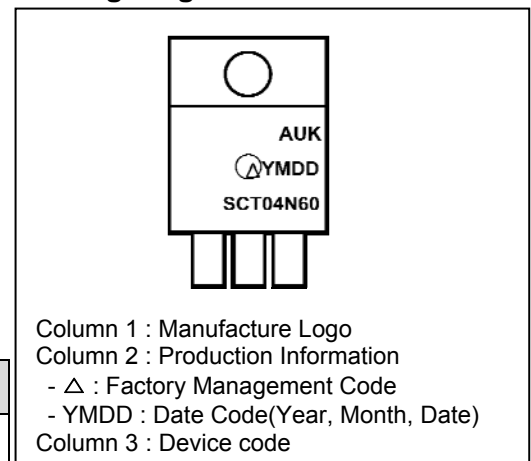

Absolute Maximum Ratings (Limiting Values)

Characteristic	Symbol	Value	Unit
Repetitive Peak Off-state Voltage	V_{DRM}	600	V
RMS on-state current (full sine wave)	$I_{T(RMS)}$	4	A
Non-repetitive surge peak on-state current (full cycle, T_j initial = 25°C)	I_{TSM}	38	A
I^2t Value for fusing	I^2t	6	A ² s
Peak gate current	I_{GM}	4	A
Peak gate power dissipation	P_{GM}	5	W
Average gate peak dissipation	$P_{G(AV)}$	0.5	W
Storage temperature range	T_{stg}	-40 to +150	°C
Operating junction temperature range	T_j	-40 to +125	°C

Thermal Characteristics

Characteristic	Symbol	Value	Unit
Maximum thermal resistance junction to case (AC)	$R_{th(j-c)}$	3.0	$^{\circ}\text{C}/\text{W}$
Maximum thermal resistance junction to ambient (AC)	$R_{th(j-a)}$	60	$^{\circ}\text{C}/\text{W}$

Electrical Characteristics ($T_J=25^{\circ}\text{C}$, unless otherwise specified)

Off Characteristics

Characteristic	Symbol	Test Condition	Min.	Typ.	Max.	Unit
Repetitive peak Off-state current	I_{DRM}	$V_D = V_{DRM}$	-	-	5	μA
Repetitive peak reverse current	I_{RRM}	$V_R = V_{RRM}$	-	-	5	μA

On Characteristics

Characteristic	Symbol	Test Condition	Min.	Typ.	Max.	Unit
Peak On-state voltage	V_{TM}	$I_T = 5.5\text{A}$	-	-	1.55	V
Holding current	I_H	$V_D = 12\text{V}, I_T = 0.2\text{A}$	-	-	40	mA
Gate trigger current	$I_{GT} (I - II - III)$	$V_D = 12\text{V}, R_L = 30\Omega$	-	-	30	mA
	$I_{GT} (IV)$	-	-	-	-	mA
Gate trigger voltage	$V_{GT} (I - II - III)$	$V_D = 12\text{V}, R_L = 30\Omega$	-	-	1.3	V
Gate Non-trigger voltage	V_{GD}	$V_D = 2/3 V_{DRM}, T_J=125^{\circ}\text{C}$	0.2	-	-	V

Dynamic Characteristics

Characteristic	Symbol	Test Condition	Min.	Typ.	Max.	Unit
Critical rate of rise of Off-state Voltage	$(dV/dt)_S$	$V_D = 2/3 V_{DRM}, T_J=125^{\circ}\text{C}$	100	-	-	$\text{V}/\mu\text{S}$
Rate of Change of Commutation Current	$(dI/dt)_C$	$(dV/dt)_C=10\text{V}/\mu\text{s} \downarrow, T_J=125^{\circ}\text{C}$	2.5	-	-	A/ms
Critical rate of rise of on-state current	dI/dt	$f=120\text{Hz}, I_G = 2 \times I_{GT}$ $t_r \leq 100 \text{ ns}, T_J=125^{\circ}\text{C}$	-	-	50	$\text{A}/\mu\text{S}$

Simple circuit for $(dV/dt)_S$

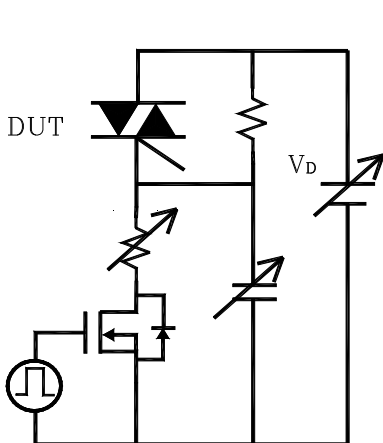

Simple circuit for $(dI/dt)_C$ vs $(dV/dt)_C$

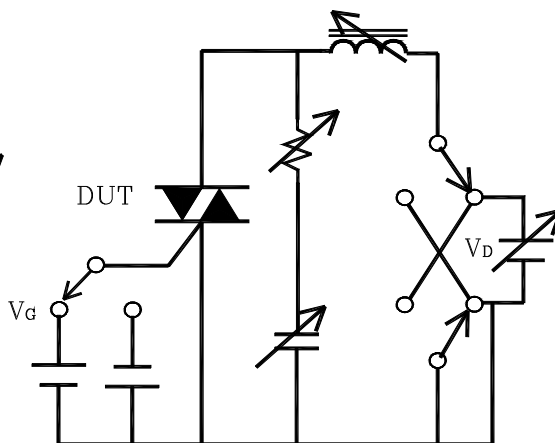

Simple circuit for dI/dt

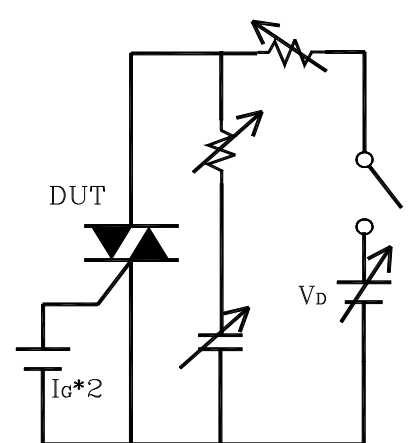

Electrical Characteristic Curves

Fig. 1 $P - I_{T(RMS)}$

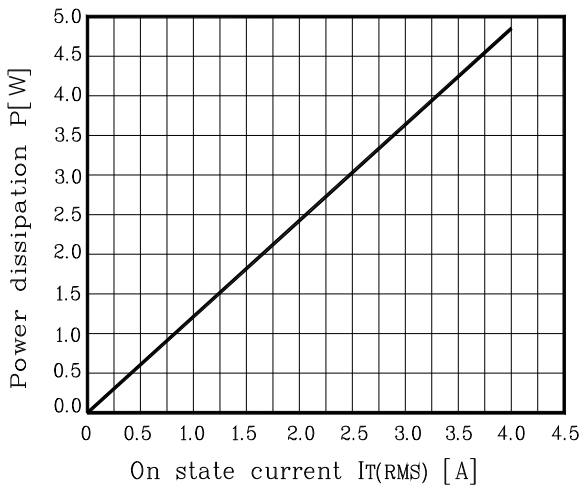

Fig. 2 $I_{T(RMS)} - T_c$

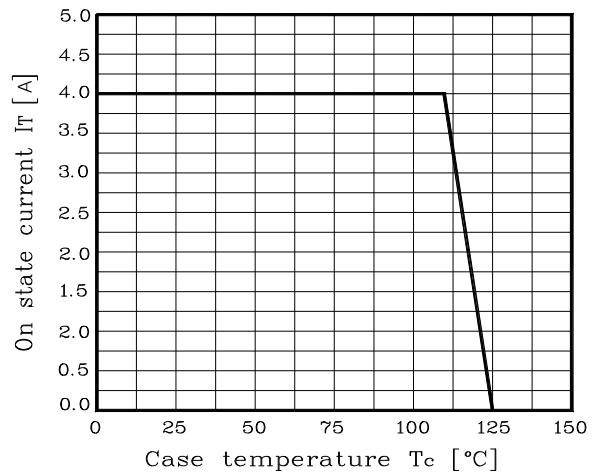

Fig. 3 $I_T - V_T$

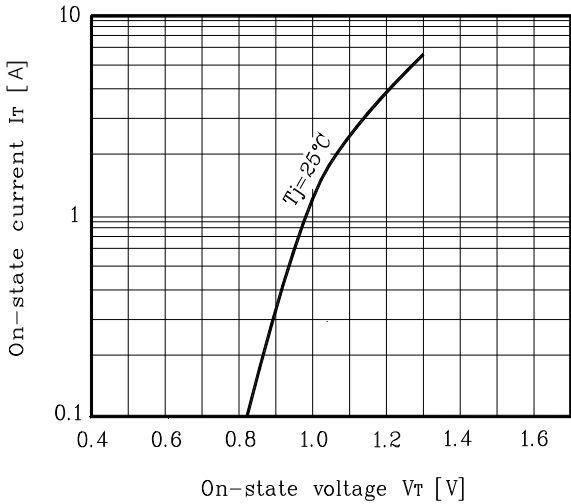

Fig. 4 $(di/dt)_c - (dV/dt)_c$

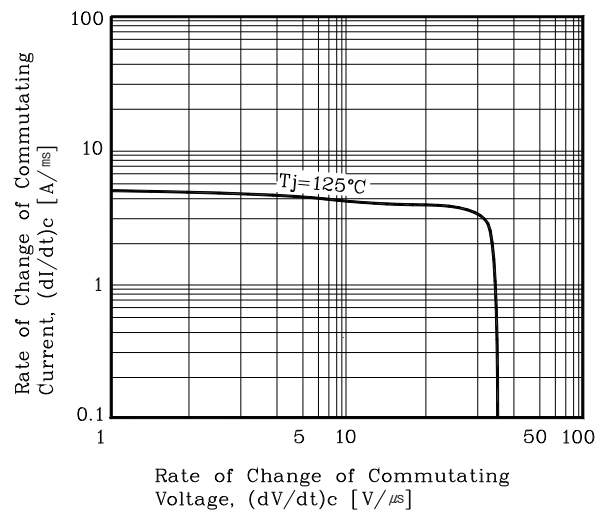

Fig. 5 $I_{GT} - T_j$

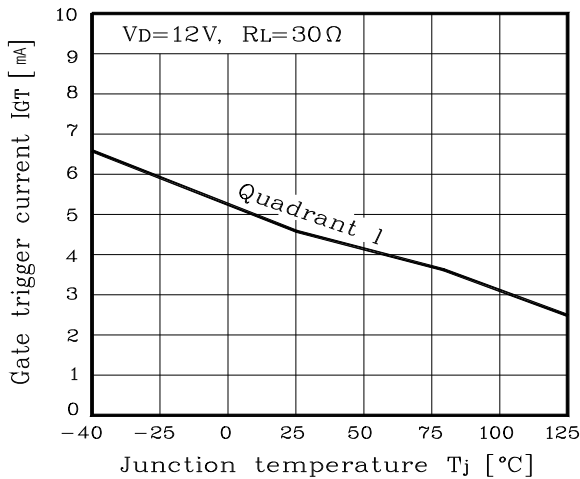
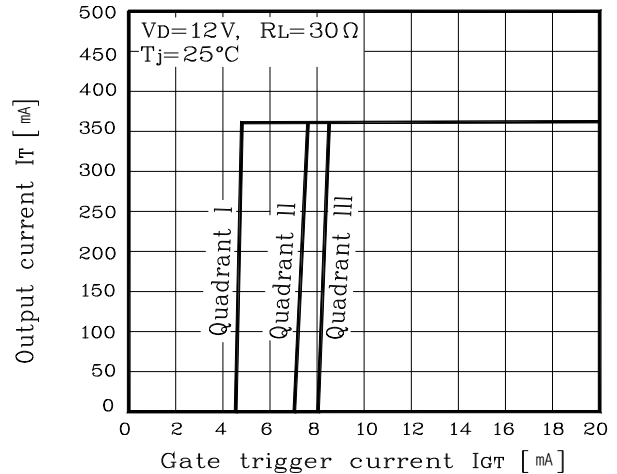

Fig. 6 $I_T - I_{GT}$



Electrical Characteristic Curves

Fig. 7 $V_{GT} - T_j$

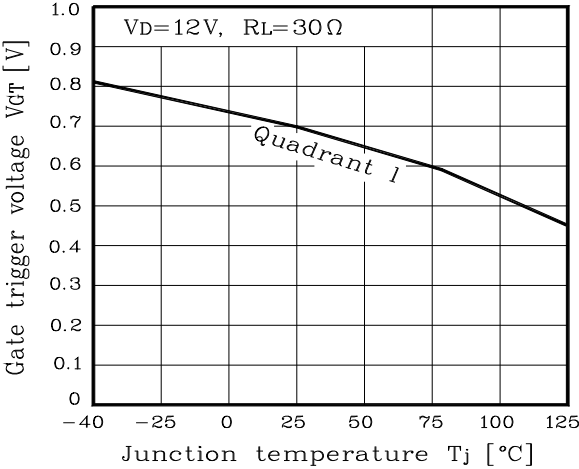

Fig. 8 $I_T - V_{GT}$

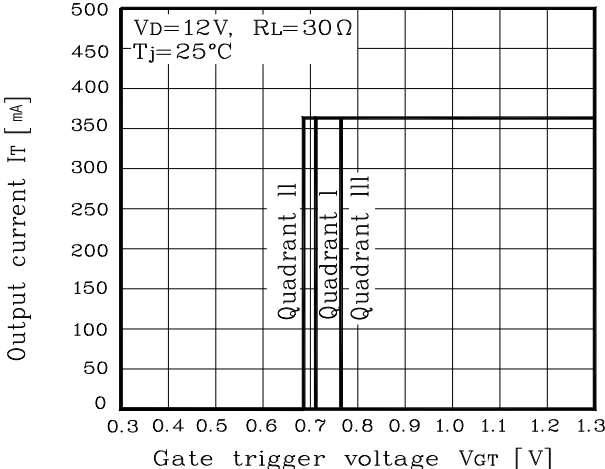
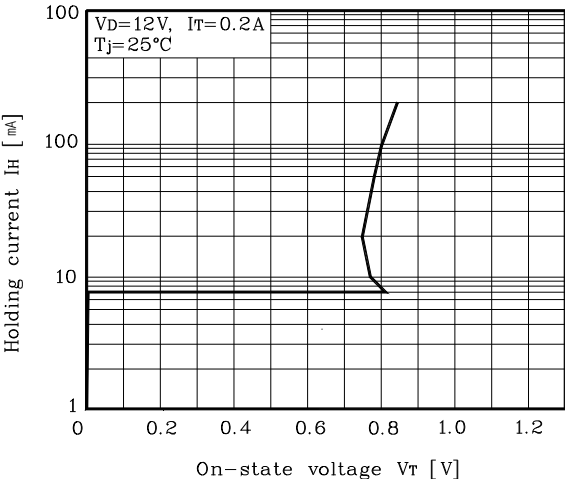
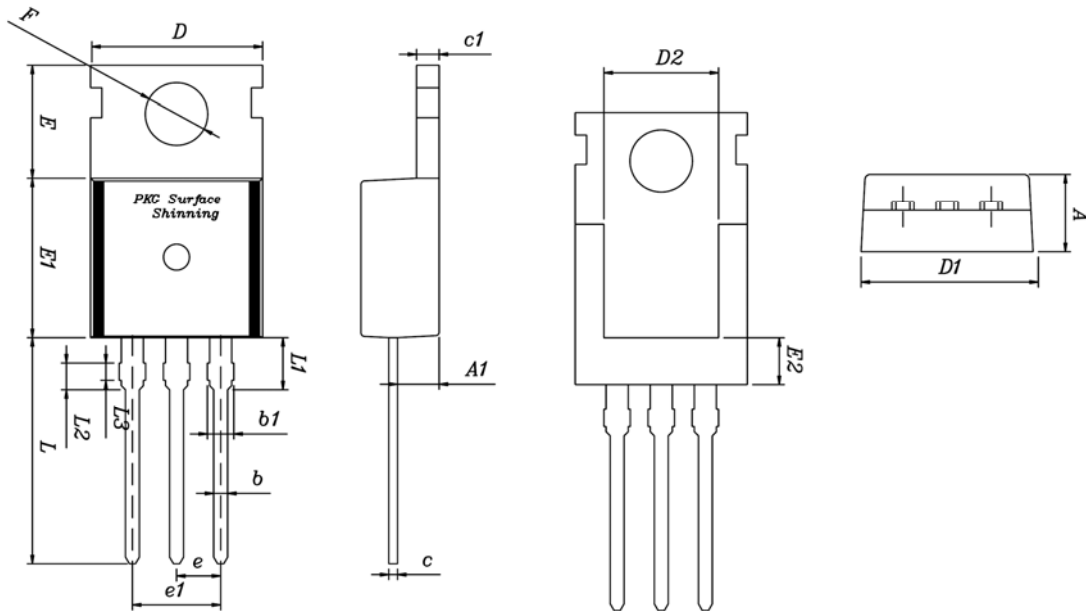

Fig. 9 $I_H - V_T$



Package Outline Dimension



SYMBOL	MILLIMETERS			NOTE
	MINIMUM	NOMINAL	MAXIMUM	
A	4.35	4.50	4.65	
A1	2.20	2.40	2.60	
b	0.65	0.80	0.95	
b1	1.42	1.52	1.62	
C	0.40	0.50	0.60	
C1	1.20	1.30	1.40	
D	9.80	10.00	10.20	
D1	9.85	10.00	10.15	
D2	6.40	6.60	6.80	
E	6.30	6.50	6.70	
E1	9.05	9.20	9.35	
E2	2.50	2.70	2.90	
F	3.50	3.60	3.70	
e	2.34	2.54	2.64	
e1	4.88	5.08	5.28	
L	12.68	13.08	13.48	
L1	2.80	3.00	3.20	
L2	1.49	1.54	1.59	
L3	0.95	1.00	1.05	

The AUK Corp. products are intended for the use as components in general electronic equipment (Office and communication equipment, measuring equipment, home appliance, etc.).

Please make sure that you consult with us before you use these AUK Corp. products in equipments which require high quality and / or reliability, and in equipments which could have major impact to the welfare of human life(atomic energy control, airplane, spaceship, transportation, combustion control, all types of safety device, etc.). AUK Corp. cannot accept liability to any damage which may occur in case these AUK Corp. products were used in the mentioned equipments without prior consultation with AUK Corp..

Specifications mentioned in this publication are subject to change without notice.