

SOP-8
Description

The S8082 is a monolithic integrated circuit designed for driving bi-directional DC motor with braking mode and speed control mode, and it is suitable for the loading motor driver of VCR, CDP, and TOY systems. The speed control can be achieved by adjusting the external voltage of the speed control pin. It has two pins of logic inputs for controlling the forward/reverse and braking.

Application

◆ VCR

Low current DC motor such as audio or video equipment.

◆ CD-Player

Compact disk player (CDP) tray or changer

◆ TOY Systems

◆ General DC motor

ORDERING INFORMATION

Product Name	Marking	Package Name
S8082	S8082	SOP8

▲ Marking Information



① Device Code

② Year & Week Code

Features and Benefits

- ◆ Built-in brake function for stable brake characteristics.
- ◆ Built-in element to absorb a surge current derived from changing motor direction and braking motor drive.
- ◆ Motor speed direction change.
- ◆ Stable motor direction change.
- ◆ Interfaces with CMOS devices.
- ◆ Built-in the thermal shut down circuit (175 °C)
- ◆ Low standby current (6.5mA)
- ◆ Wide operating supply voltage range (4.3V ~ 13.2V)

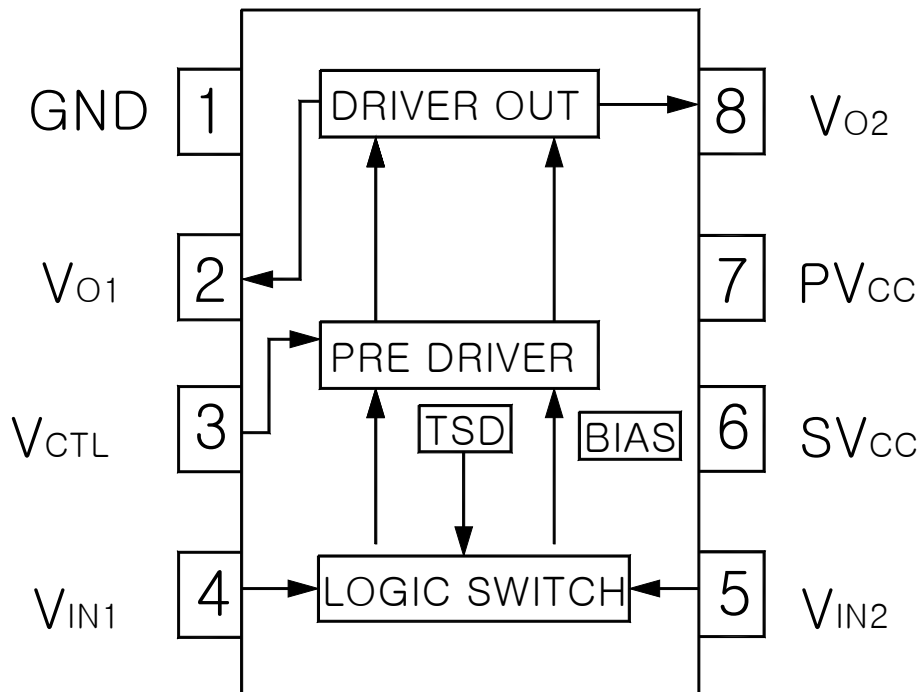
◆ Internal Block Diagram & Pin Assignment



◆ Pin Description

NO	SYMBOL	I/O	DESCRIPTION
1	GND	-	Ground
2	V _{O1}	O	Output 1
3	V _{CTL}	I	Motor speed control
4	V _{IN1}	I	Input 1
5	V _{IN2}	I	Input 2
6	SV _{CC}	-	Supply voltage (Signal)
7	PV _{CC}	-	Supply voltage (Power)
8	V _{O2}	O	Output 2

◆ Absolute Maximum Ratings (Ta = 25°C)

Parameter	Symbol	Limits	Unit
Maximum Supply Voltage	V _{cc}	18	V
Maximum Output Current	I _O	0.8	A
Power Dissipation	P _d	600	mW
Operate Temperature Range	T _{opr}	-25 ~ +85	°C
Storage Temperature Range	T _{stg}	-55 ~ +150	°C

[P_d] When mounted on a 70mm×70mm×1.6mm glass epoxy board.

Reduced by 4.84mW for each increase in T_a of 1°C.

[I_O] Duty 1 / 100, pulse width 500us.

[T_{stg}] Should not exceed P_d or SOA and T_j=150°C values.

◆ Recommended Operating Conditions (Ta = 25°C)

Parameter	Symbol	Limits	Unit
Supply Voltage	SV _{CC}	4.3 ~ 13.2	V
	PV _{CC}	4.3 ~ SV _{CC}	V

VCTL Pin is connected to the VCC line with 2×V_{be} + 1V_{cesat} [approximately 1.7V].

So, V_{cc} should be supplied more than V_{zener}+1.7V for using stable area of zener diode.

◆ Power Dissipation Curve [P_d]

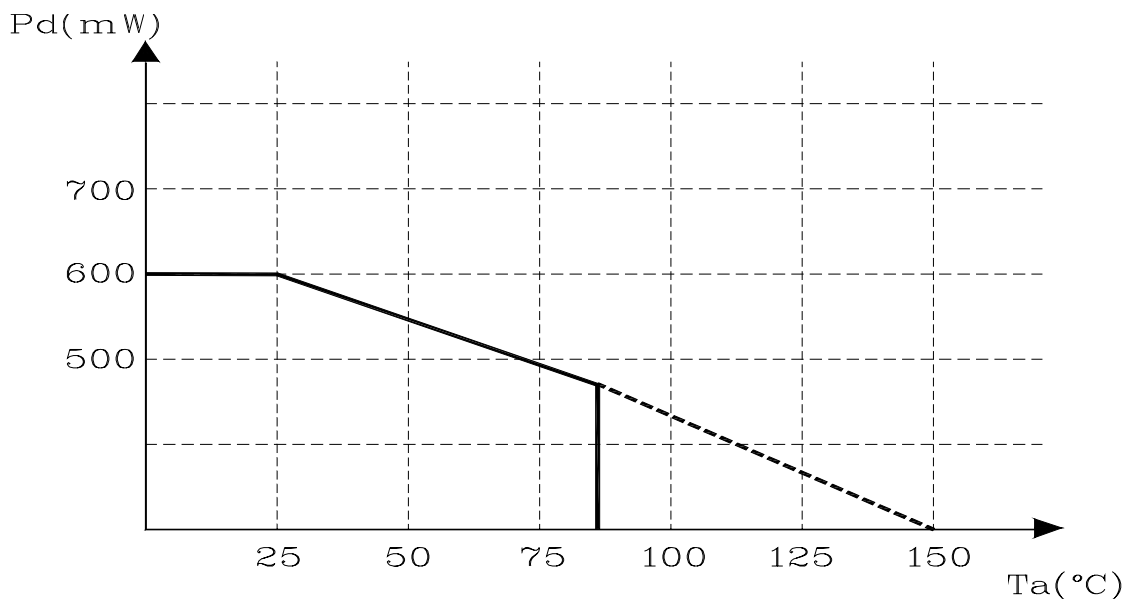

◆ 70mm×70mm×1.6mm glass epoxy board .

◆ Electrical characteristics

(Unless otherwise specified Ta=25 °C, PV_{CC}=SV_{CC}=12V)

NO	Characteristics	Symbol	Condition	Specification			Unit
				MIN.	TYP.	MAX.	
1	Quiescent circuit current	I _{CC}	Pin4, Pin5 = GND, RL = Open	4	6.5	9.5	mA
2	Minimum input on current 1	I _{MIN1}	Pin4 = I _{IN1} , Pin5 = L, RL= Open	-	10	30	uA
3	Minimum input on current 2	I _{MIN2}	Pin4 = L, Pin5 = I _{IN2} , RL= Open	-	10	30	uA
4	Input threshold voltage 1	V _{ITH1}	Pin4 = V _{IN1} , Pin5 = L, RL= Open	1	1.3	1.6	V
5	Input threshold voltage 2	V _{ITH2}	Pin4 = L, Pin5 = V _{IN2} , RL= Open	1	1.3	1.6	V
6	Output leakage current 1	I _{OL1}	Pin4 = Pin5 = GND, RL = Open	-	0.01	1	mA
7	Output leakage current 2	I _{OL2}	Pin4 = Pin5 = GND, RL = Open	-	0.01	1	mA
8	Zener Current 1	I _{Z1}	Pin4 = H, Pin5 = L, RL = Open	-	0.85	1.5	mA
9	Zener Current 2	I _{Z2}	Pin4 = L, Pin5 = H, RL = Open	-	0.85	1.5	mA
10	Output voltage 1	V _{O1}	Pin4 = H, Pin5 = L, RL = 60Ω	6.6	7.2	7.4	V
11	Output voltage 2	V _{O2}	Pin4 = L, Pin5 = H, RL = 60Ω	6.6	7.2	7.4	V
12	Saturation voltage 1(Upper)	V _{SAT1}	I _o = 300mA	-	1.9	2.3	V
13	Saturation voltage 2(Upper)	V _{SAT2}	I _o = 500mA	-	1.9	2.3	V
14	Saturation voltage 1(Lower)	V _{SAT3}	I _o = 300mA	-	0.25	0.5	V
15	Saturation voltage 2(Lower)	V _{SAT4}	I _o = 500mA	-	0.4	0.6	V

Application Information

1. Thermal Shut Down Circuit

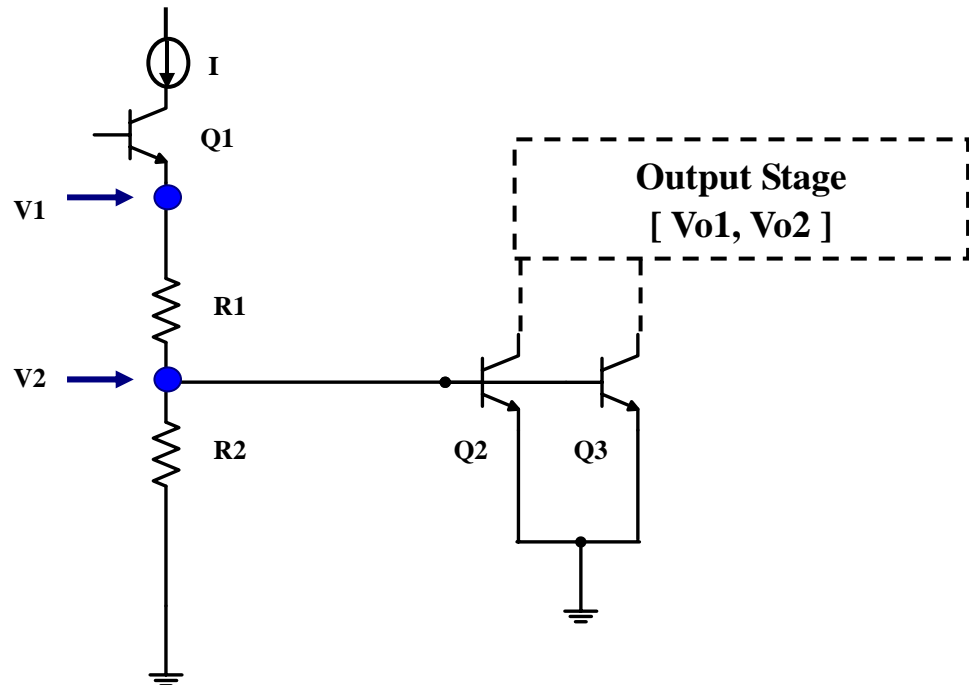

The built-in thermal shutdown circuit mutes the output current when the chip temperature reaches 175°C (typ.). The hysteresis is set to 25°C (typ.) by IHys, so the circuit will start up again when the chip temperature falling down to 150°C (typ.)

When $T_a = 25^{\circ}\text{C}$, Q2 & Q3 are turned-off [Output Stage : Normality Operation]

$$V1 = I \times (R1 + R2)$$

$$V2 = R2 \div (R1 + R2) \times V1 = 0.385\text{V}$$

When $T_a = 175^{\circ}\text{C}$, Q2 & Q3 are turned-on [Output Stage : Shut Down]

$$0.700\text{V} - 0.385\text{V} = 315\text{mV}$$

[Vbe level of Q2 & Q3 : 0.700V / Temperature Coefficient of Q2 = Q3 = $-1.8\text{mV}/^{\circ}\text{C}$]

◆ T.S.D : $315\text{mV} \div 1.8\text{mV} = 175^{\circ}\text{C}$

2. Input Logic

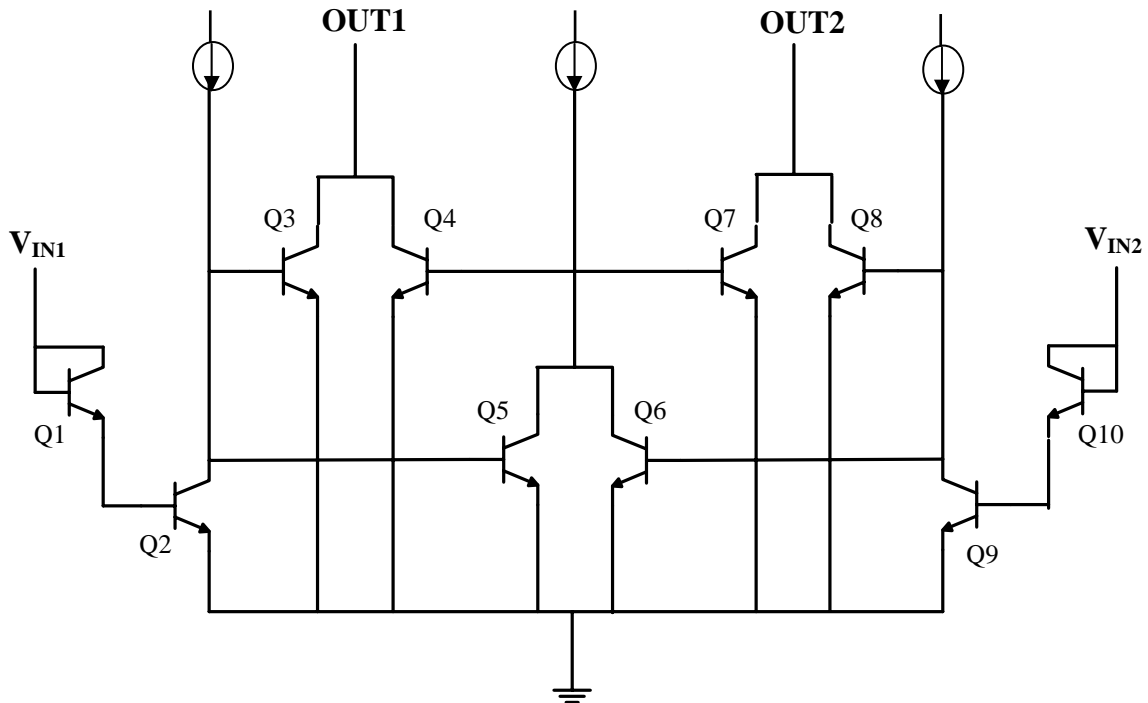

$V_{IN1} > 2V_{be}$, Q2 = On $V_{IN1} < 2V_{be}$, Q2 = Off below 1.2V (typ.), the output current is muted.

[Logic Input to Output Table]

Input Logic		Output Logic		Motor Status
VIN 1 (Pin 4)	VIN 2 (Pin5)	Vo 1 (Pin2)	Vo 2(Pin8)	
L	L	L	L	Stand-By
H	L	H	L	Forward Rotation
L	H	L	H	Reverse Rotation
H	H	L	L	Brake

* VIN1/VIN2 Recommended Conditions

[Input High is 2.0V to Vcc / Input Low is below 0.8V]

3. Output Part Circuit & Speed Control

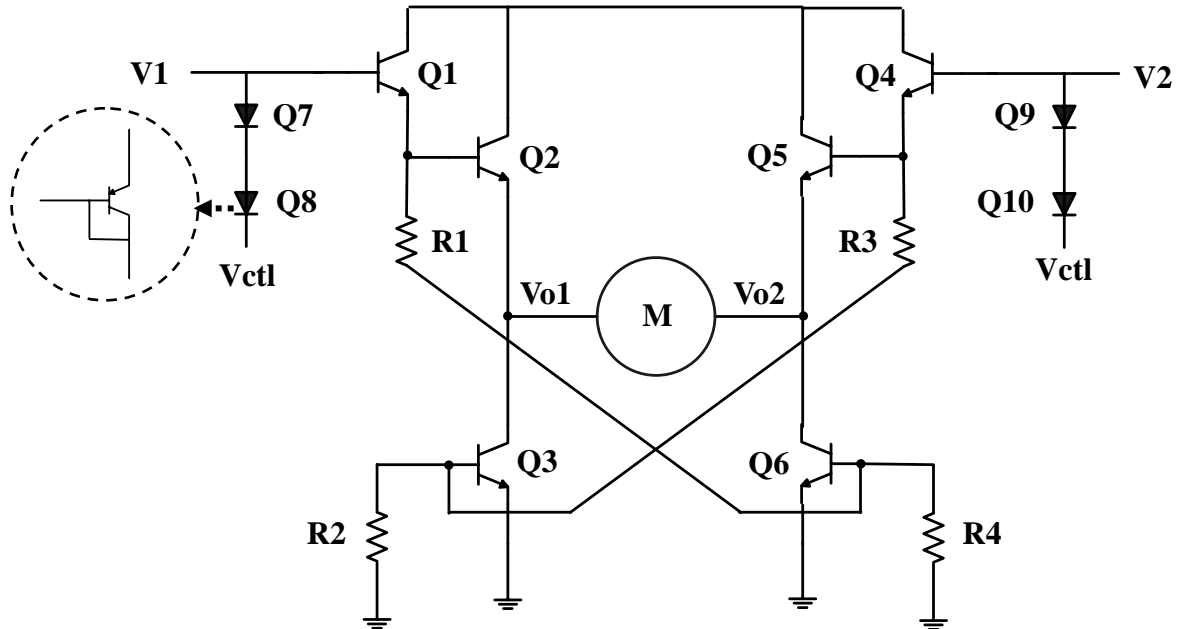

[Forward Rotation : VIN1(H), VIN2(L)]

$$V1 = Vctl + 2 V_{be}(Q7, Q8)$$

$$Vo1 = V1 - 2V_{be}(Q1, Q2) = Vctl + 2 V_{be}(Q7, Q8) - 2V_{be}(Q1, Q2) = Vctl$$

$$Vo2 = V_{sat}(Q6)$$

$$Vout = Vo1 - Vo2 = Vctl - V_{sat}(Q6)$$

[* Therefore, Vout level depends on the Vctl pin's level for Speed Control]

Characteristic Diagrams

Fig. 1 $V_{CC} - I_{CC}$

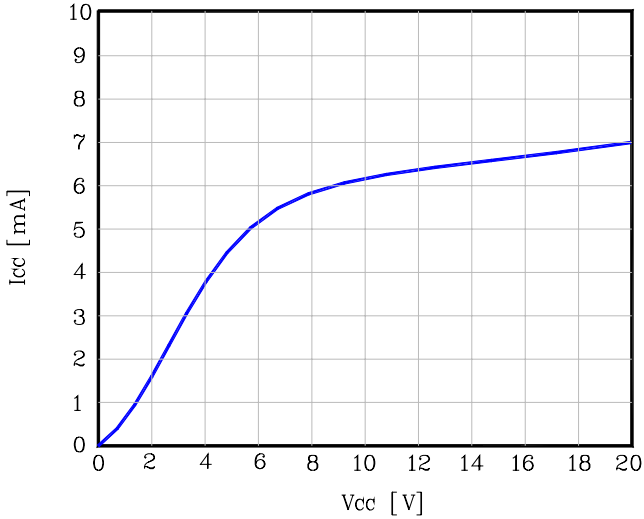

Fig. 2 Temperature - I_{CC}

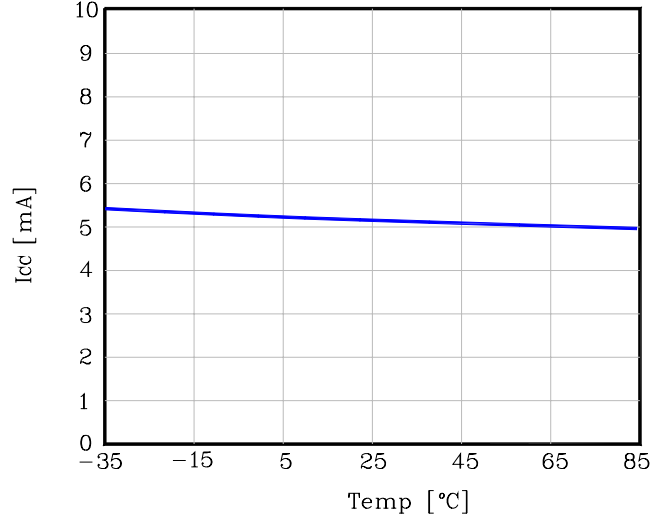

Fig. 3 $V_{CTL} - V_O$

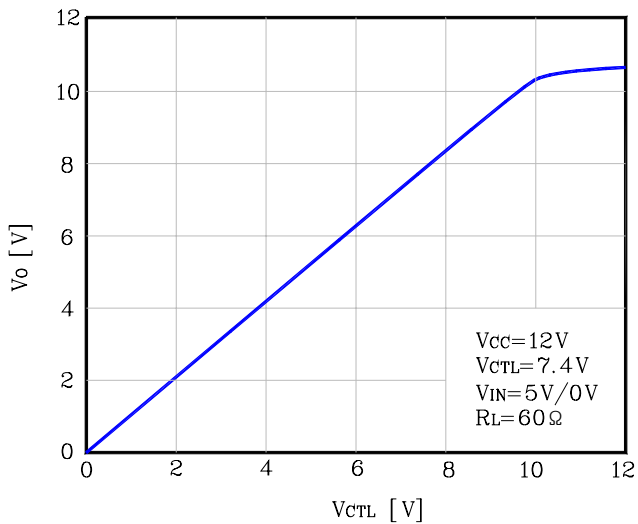

Fig.4 Temperature - V_O

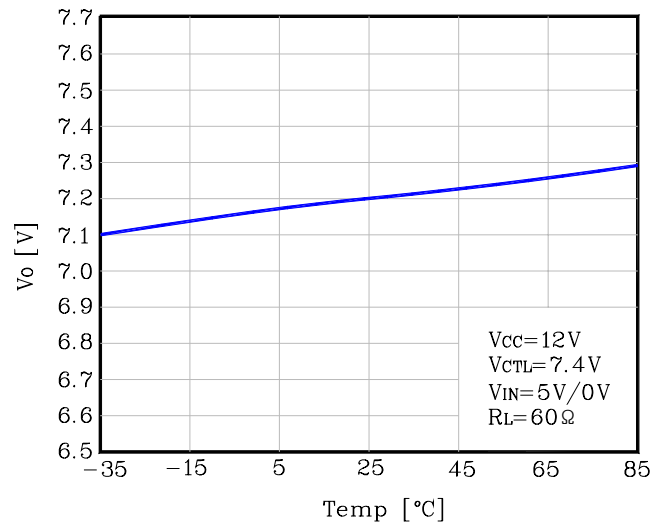

Fig. 5 $I_O - V_{SAT}$ (Upper)

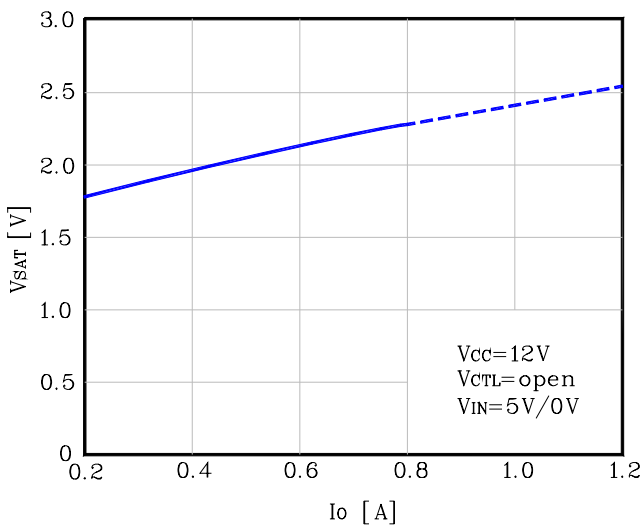
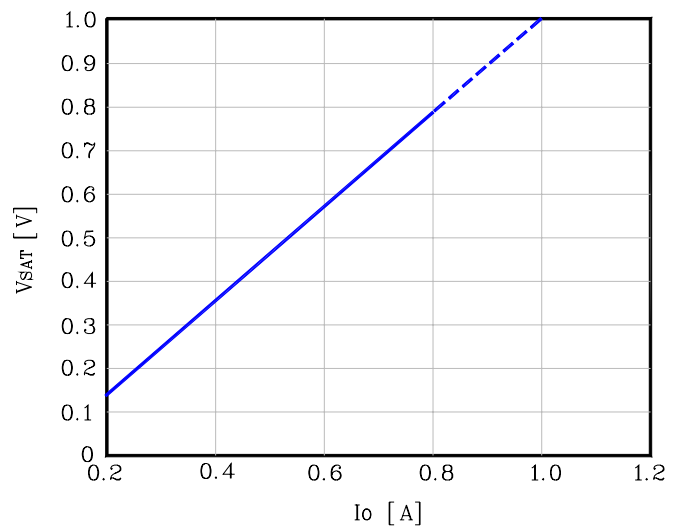
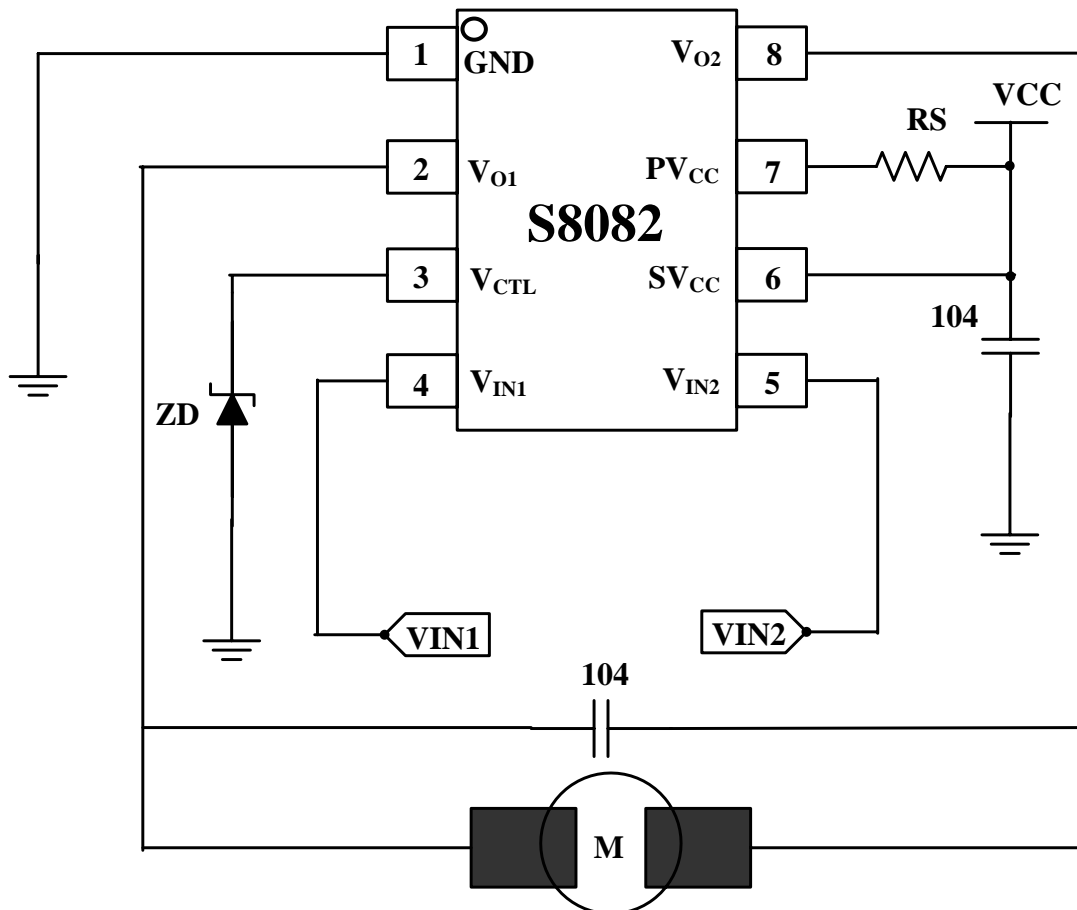

Fig.6 $I_O - V_{SAT}$ (Lower)



◆ Application Circuit



◆ Test Circuit

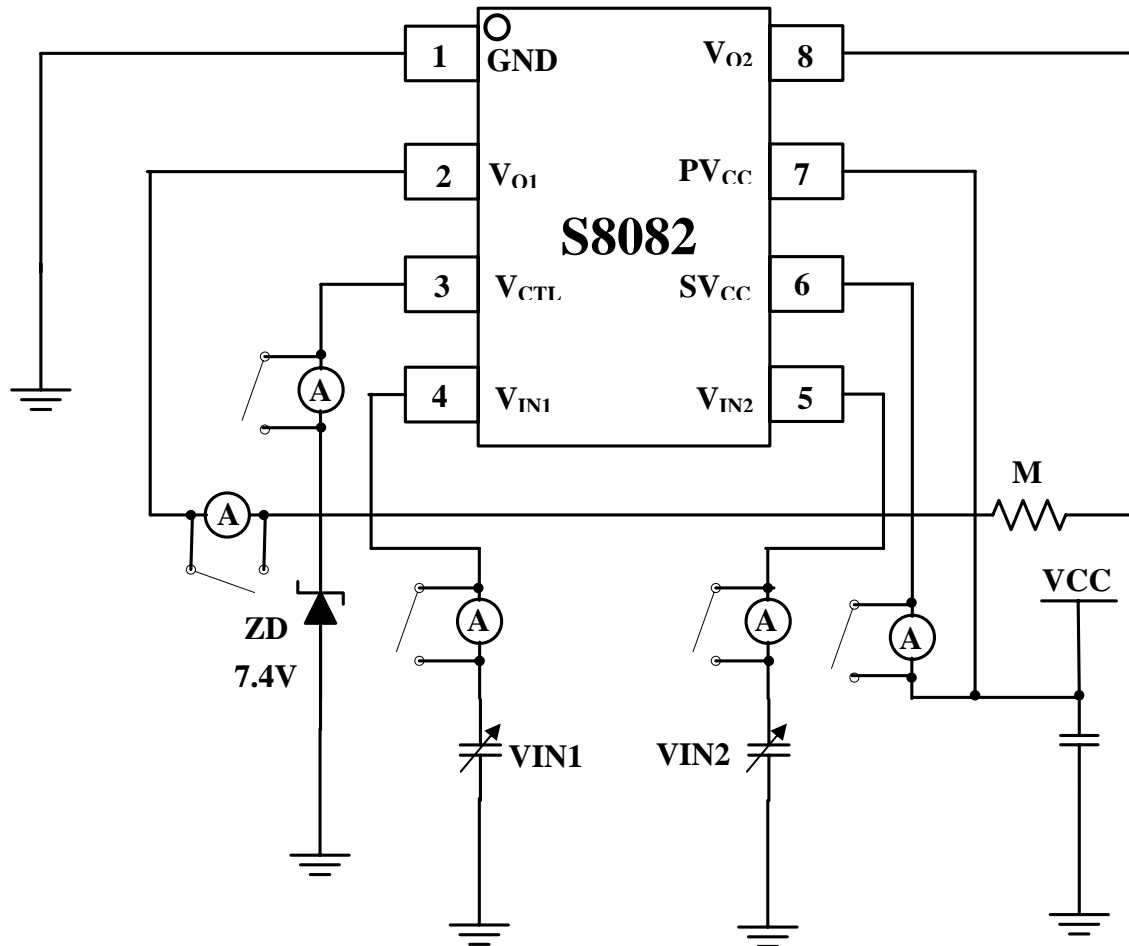

Outline Dimension

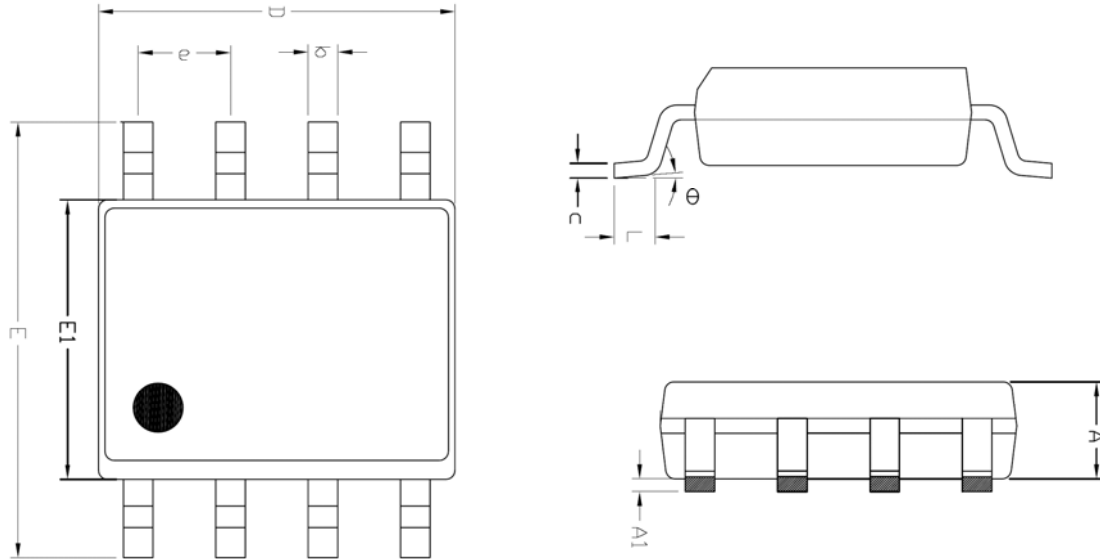

SYMBOL	MILLIMETER(mm)			NOTE
	MINIMUM	NOMINAL	MAXIMUM	
A	1.245	—	1.445	
A1	0.125	0.175	0.275	
b	0.320	0.420	0.520	
c	0.170	0.220	0.270	
D	4.802	4.902	5.002	
E	5.870	6.020	6.170	
E1	3.761	3.861	3.961	
e	1.270 BSC			
L	0.462	0.562	0.662	
θ	0 °	—	8 °	

The AUK Corp. products are intended for the use as components in general electronic equipment (Office and communication equipment, measuring equipment, home appliance, etc.).

Please make sure that you consult with us before you use these AUK Corp. products in equipments which require high quality and / or reliability, and in equipments which could have major impact to the welfare of human life(atomic energy control, airplane, spaceship, transportation, combustion control, all types of safety device, etc.). AUK Corp. cannot accept liability to any damage which may occur in case these AUK Corp. products were used in the mentioned equipments without prior consultation with AUK Corp..

Specifications mentioned in this publication are subject to change without notice.