

## Description

It is Adaptable to a Discontinuous Mode of Operation that the S6503/P is Advanced PFC (Power Factor Correction) Controller for the High Density Switching Mode Power Supply and Electronic Ballast systems. The Bulky External components are eliminated in the Internal Start-up circuits, though it is taken in Independent Boost Converter Operation. What is more, instead of the External components, the Low Pass Filter is mounted in Internal Current Sense block. Internal Clamping of the Error Amplifier and Multiplier Output improve turn on Overshoot Characteristics and Current Limiting. The One of features is able to prevent Abnormal Condition, Open Lamp & Over Voltage.

## Features

- Very Precise Adjustable Output OVP (Dynamic & Static OVP Function)
- Extremely Low Start-Up Current
- Low Operating Supply Current
- Internal Start-Up Timer
- Power Factor Maximizer & THD Minimizer Circuit
- Complete Wide Range Operation
- Feedback Open Protection
- Minimum On Timer
- Current Sense Filter On Chip
- Disable Function
- Extremely Minimized External Part Counts High Speed Response Time

## Applications

- Switching Mode Power Supply (SMPS)
- Electronic Ballast

## Ordering Information

Type NO.	Marking	Package Code
S6503	S6503	SOP-8
S6503P	S6503	DIP - 8



## Absolute Maximum Ratings

Characteristics	Symbol	Value	Unit	
Maximum Supply Voltage	$V_{CCMAX}$	27	V	
Output Peak Current	$I_{PEAK}$	$\pm 500$	mA	
Analog Input & Output (Pin 1,2,3,4,5)	$V_{INMAX}$	-0.3 ~ 7	V	
ZCD Input Maximum Current	$I_{ZCD}$	$\pm 10$	mA	
Power Dissipation	$P_{DMAX}$	SOP-8	600	mW
		DIP-8	800	
Operating Junction Temperature	$T_j$	-35 ~ 150	°C	
Storage Temperature	$T_{stg}$	-55 ~ 150	°C	

## Electrical Characteristics

( $T_a = -25^\circ\text{C}$  to  $125^\circ\text{C}$ ,  $V_{CC}=14\text{V}$  unless otherwise specified.)

Characteristics	Symbol	Test Condition	Min.	Typ.	Max.	Unit
<b>Supply Voltage &amp; Current Section</b>						
$V_{CC}$ Turn-On Threshold	$V_{CC(On)}$	$V_{CC}$ Increasing	11	12	13	V
$V_{CC}$ Turn-Off Threshold	$V_{CC(Off)}$	$V_{CC}$ Decreasing	8.7	9.5	10.3	V
Hysteresis Voltage	HYS		2	2.5	3	V
Start-Up Current	$I_{ST}$	Before Turn-On	20	40	70	$\mu\text{A}$
Quiescent Current	$I_Q$	No Switching	1	4	6	mA
Operating Supply Current	$I_{CC}$	$C_L=1\text{nF}$ , $f_{sw}=50\text{KHz}$	2	5	8	mA
Operating Current at OVP	$I_{CC\_OVP}$	$V_{INV}=2.7\text{V}$	0.5	2	4	mA
Operating Current at Disable	$I_{CC\_DIS}$	$V_{ZCD}<150\text{mV}$	0.5	2	4	mA
<b>Error Amplifier Section</b>						
Input Voltage	$V_{INV}$	$T_a=25^\circ\text{C}$	2.465	2.5	2.535	V
Line Regulation	$dV_{INV}$	$V_{CC}=12 \sim 27\text{V}$	-	0.1	5	mV
Input Bias Current	$I_{INV}$		-0.5	-0.1	0.5	$\mu\text{A}$
Open Loop Gain	$A_V$		60	80	-	dB
Gain Bandwidth	GB		-	1	-	MHz
Output Source Current	$I_{SOURCE}$	$V_{COMP}=4\text{V}$ , $V_{INV}=2.4\text{V}$	-2	-4	-	mA
Output Sink Current	$I_{SINK}$	$V_{COMP}=4\text{V}$ , $V_{INV}=2.6\text{V}$	3	5	-	mA
Upper Clamp Voltage	$V_{UPPER}$	$I_O=-100\mu\text{A}$ , $V_{INV}=2.4\text{V}$	-	5.6	-	V
Lower Clamp Voltage	$V_{LOWER}$	$I_O=100\mu\text{A}$ , $V_{INV}=2.6\text{V}$	-	2.25	-	V
Feedback Open Protection Threshold Voltage	$V_{fo}$	$V_{INV}$ Decreasing	150	200	250	mV

## Electrical Characteristics (Continued)

( $T_a = -25^{\circ}\text{C}$  to  $125^{\circ}\text{C}$ ,  $V_{CC}=14\text{V}$  unless otherwise specified.)

Characteristics	Symbol	Test Condition	Min.	Typ.	Max.	Unit
<b>Multiplier Section</b>						
Linear Operating Voltage	$V_{MULT}$		2.8	3.2	-	V
Output Maximum Slope	$dV_{CS}/dV_{MULT}$	$V_{MULT} = 0.5 \sim 0.9\text{V}$ , $V_{COMP} = \text{Upper Clamp}$	1.3	1.5	1.7	V/V
Mltiplier Gain	K	$T_a=25^{\circ}\text{C}$ , $V_{MULT}=1\text{V}$ $V_{COMP}=3.5\text{V}$	0.5	0.65	0.75	1/V
<b>Current Sense (CS) Section</b>						
Reference Clamp Voltage	$V_{CS}$	$V_{MULT}=2.5\text{V}$ , $V_{COMP}=\text{Upper Clamp}$	1.65	1.75	1.85	V
Input Bias Current	$I_{CS}$	$V_{CS} = 0 \sim 1.6\text{V}$	-0.5	-0.1	0.5	$\mu\text{A}$
Delay to Output	$T_{d(H-L)}$		-	200	-	ns
<b>Zero Current Detector (ZCD) Section</b>						
Input Threshold Voltage	$V_{ZCD}$	$V_{ZCD}$ Increasing	1.8	2.1	2.4	V
Hysteresis Voltage	HY(ZCD)		-	0.5	-	V
Upper Clamp Voltage	$V_{CLAMP(H)}$	$I_{ZCD} = 3\text{mA}$	48	5.4	6	V
Lower Clamp Voltage	$V_{CLAMP(L)}$	$I_{ZCD} = -3\text{mA}$	0.3	0.6	-	V
Input Bias Current	$I_{ZCD}$	$V_{ZCD} = 1 \sim 3\text{V}$	-	1	-	$\mu\text{A}$
Source Current	$I_{SOURCE(ZCD)}$		-3	-	-	mA
Sink Current	$I_{SINK(ZCD)}$		3	-	-	mA
Disable Input Voltage	$V_{DIS}$	$V_{ZCD}$ Decreasing	150	200	250	mV
Reset Current after Disable	$I_{DIS}$	Pin5 = 0V	-30	-80	-	$\mu\text{A}$
<b>Restart Timer Section</b>						
Restart Time Delay	$t_{rst}$		70	130	300	$\mu\text{s}$

**Electrical Characteristics (Continued)**

(Ta = -25°C to 125°C, Vcc=14V unless otherwise specified.)

Characteristics	Symbol	Test Condition	Min.	Typ.	Max.	Unit
<b>Output Section</b>						
Output High Voltage	V <sub>OH</sub>	I <sub>O</sub> = -10mA	10.5	11.5	12.5	V
		I <sub>O</sub> = -100mA	10	11	12	V
Maximum Voltage	V <sub>OMAX</sub>	V <sub>CC</sub> = 20V, I <sub>O</sub> = -1mA	11	13	15	V
Output Low Voltage	V <sub>OL</sub>	I <sub>O</sub> = 10mA	-	0.1	1	V
		I <sub>O</sub> = 100mA	-	1.2	2.5	V
Output Voltage with UVLO Activated	V <sub>O(UV)</sub>	I <sub>O</sub> = 1mA	-	-	1	V
Minimum On Time	T <sub>ON(MIN)</sub>		-	150	1	ns
Output Rising Time	t <sub>r</sub>	C <sub>L</sub> = 1nF	-	50	-	ns
Output Falling Time	t <sub>f</sub>	C <sub>L</sub> = 1nF	-	50	-	ns
<b>Over Voltage Protector (OVP) Section</b>						
Dynamic OVP Current	I <sub>OVP</sub>		35	40	45	μA
Dynamic OVP Current Hysteresis	I <sub>OVP(HYS)</sub>		-	30	-	μA
Static OVP Threshold Voltage	V <sub>OVP</sub>	V <sub>INV</sub> = 2.7V	2.1	2.25	2.4	V

## Application Information

### 1. Main Inductor

$$L = \eta \times (V_O - V_P) \times V_P^2 / (4V_O \times P_O \times f)$$

Where,

$\eta$ : Efficiency (0.95)

$V_O$ : DC Link Voltage

$V_P$ : Input Peak Voltage

$P_O$ : Output Power

$f$ : Switching Frequency

### 2. Resistor for Current Sense

$$R_S = 1.75 / I_{LP}$$

Where,

$I_{LP}$ : Inductor Peak Current

### 3. Resistor for Multiplier

$$R_{ML} < 0.69 \times R_{MU} / (V_P - 0.69)$$

Where,

$R_{MU}$ : Under Resistor for Multiplier Input

$R_{ML}$ : Lower Resistor for Multiplier Input

### 4. Resistor for Error Amplifier

$$R_{EL} = 2.5 \times R_{EU} / (V_O - 2.5)$$

Where,

$R_{EU}$ : Under Resistor for Error Amplifier Inverting Input

$R_{EL}$ : Lower Resistor for Error Amplifier Inverting Input

5. Over Voltage Protector (OVP)

$$\Delta V_O = R_{EU}[\Omega] \times 40[\mu A]$$

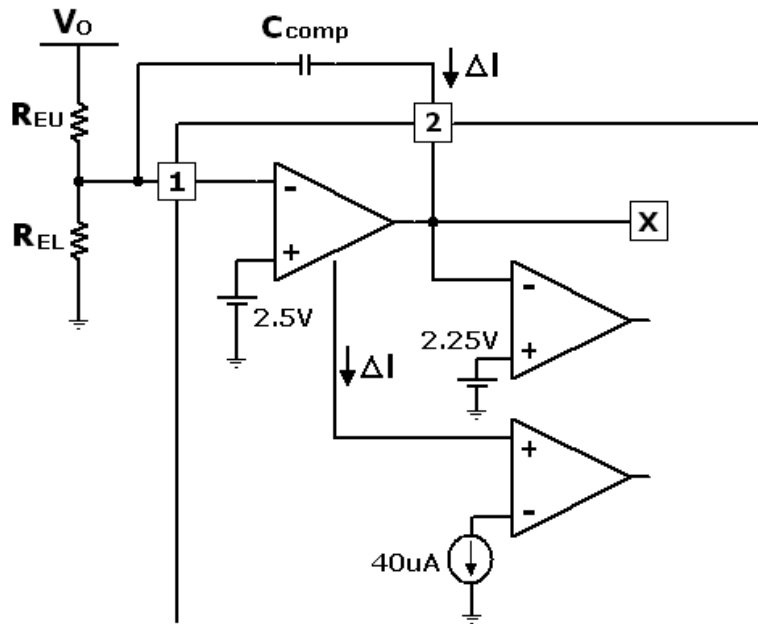

Fig.1 Over Voltage Protection Circuit

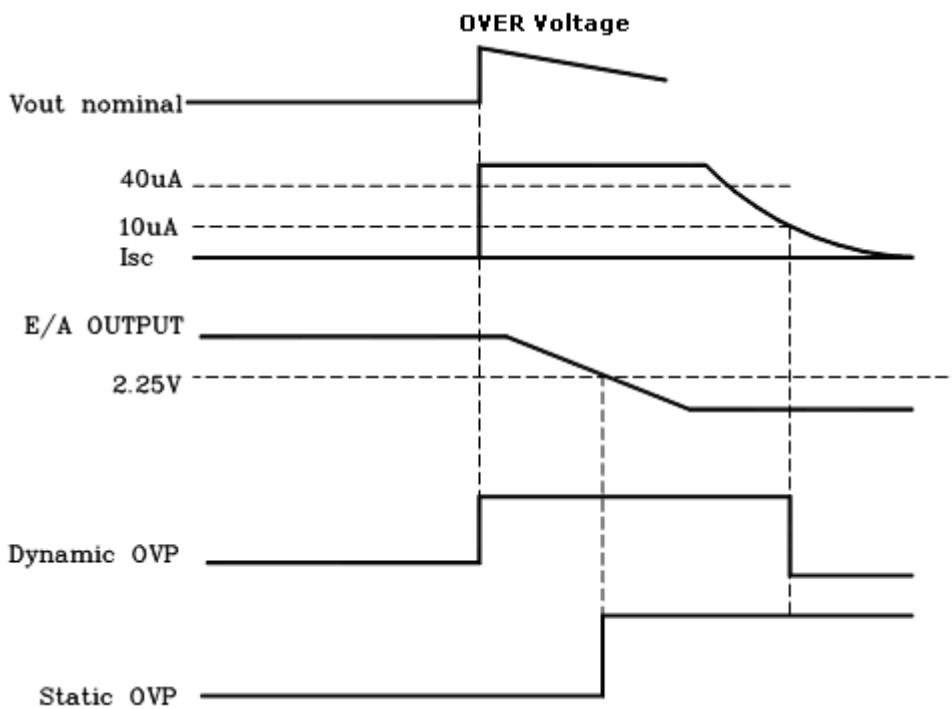
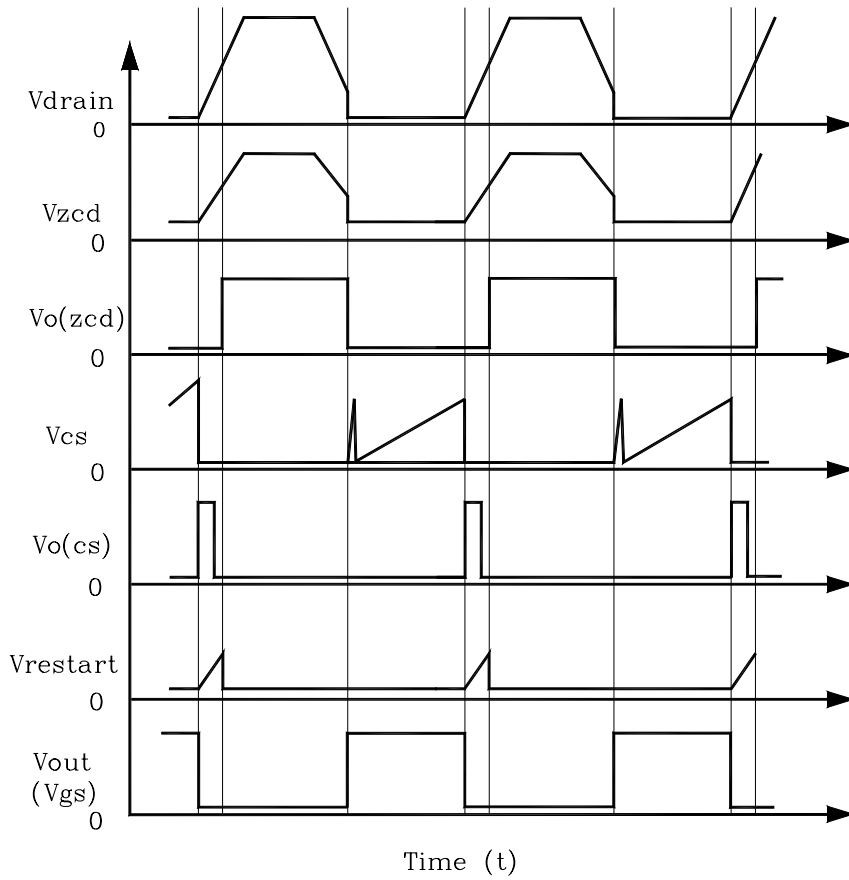
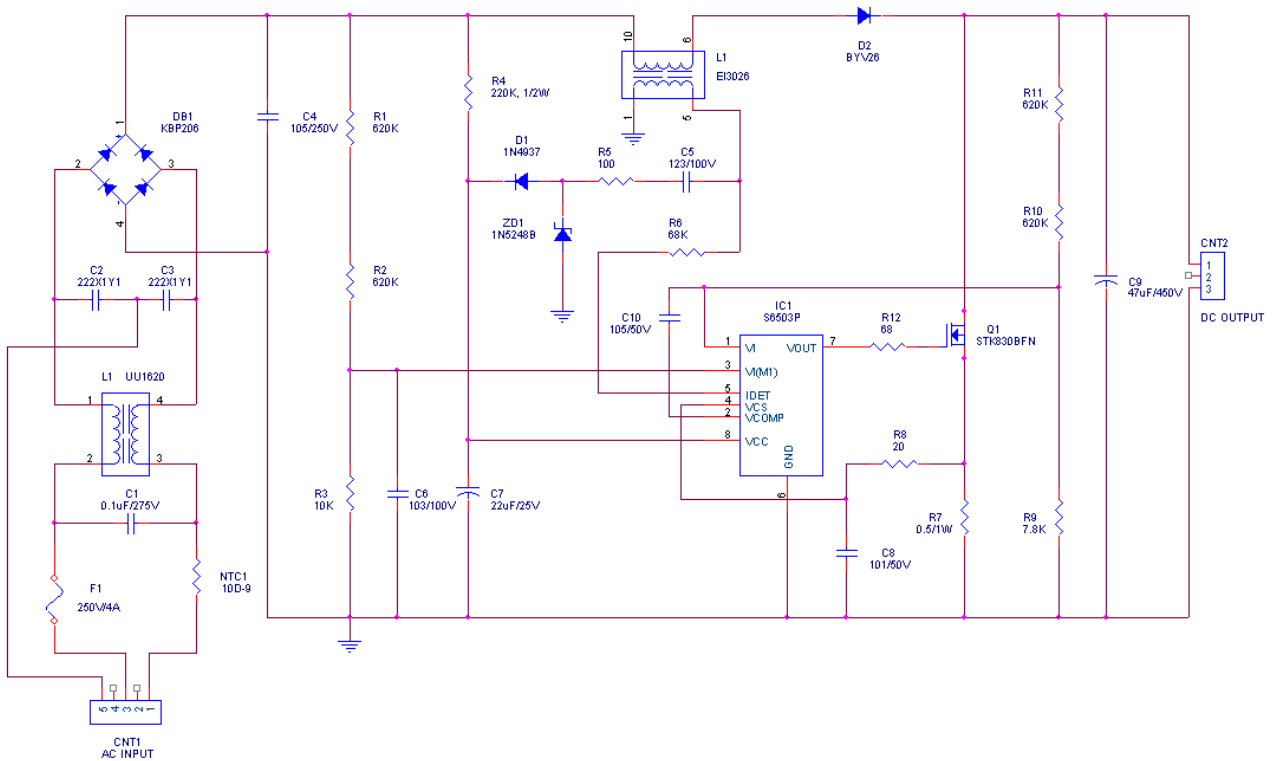

Fig.2 OVP Operating Timing Chart

### Operating Timing Chart



### Typical Application Circuit (85VAC ~ 265VAC, 80W)



## Electrical Characteristic Curves

Fig.1 Operating Supply Current

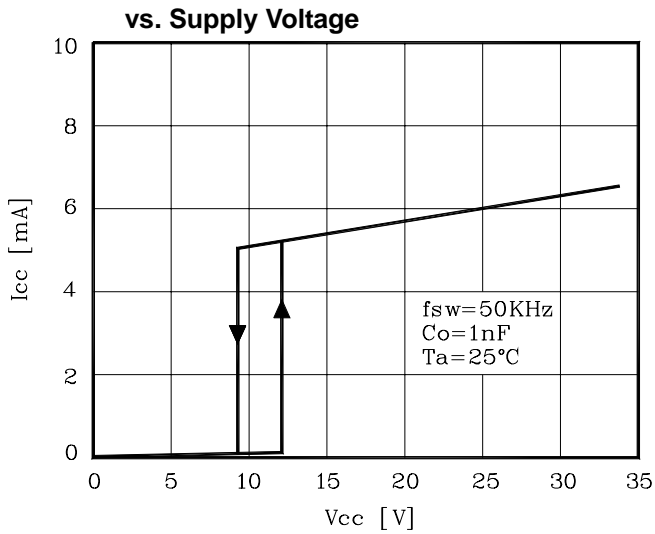

Fig.2 Start-Up Current vs. Supply Voltage

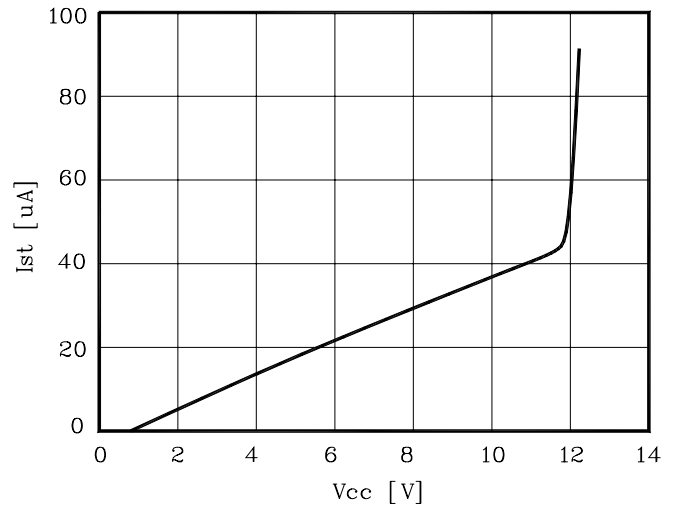

Fig.3 Output Voltage

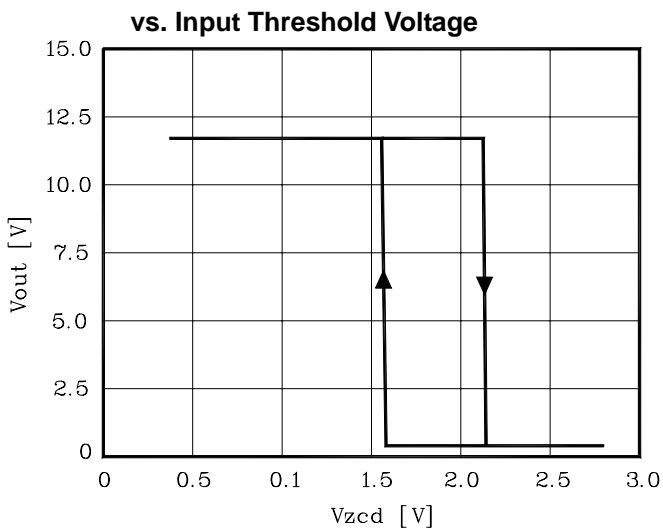

Fig.4 Output Voltage

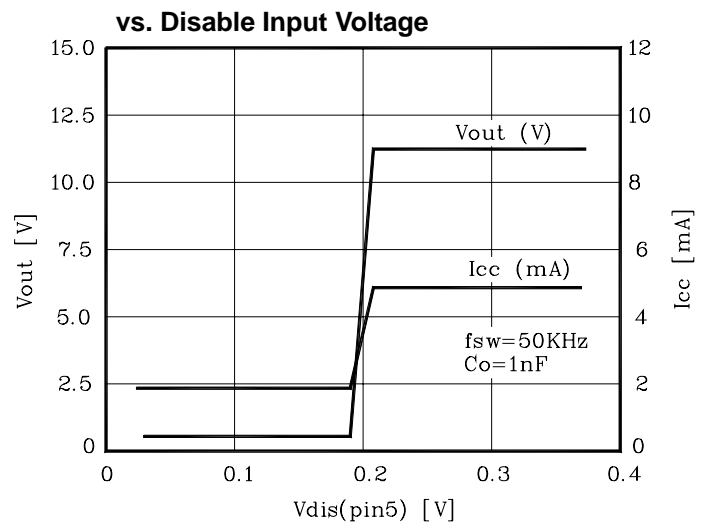

Fig. 5 Output Voltage vs. Input Voltage

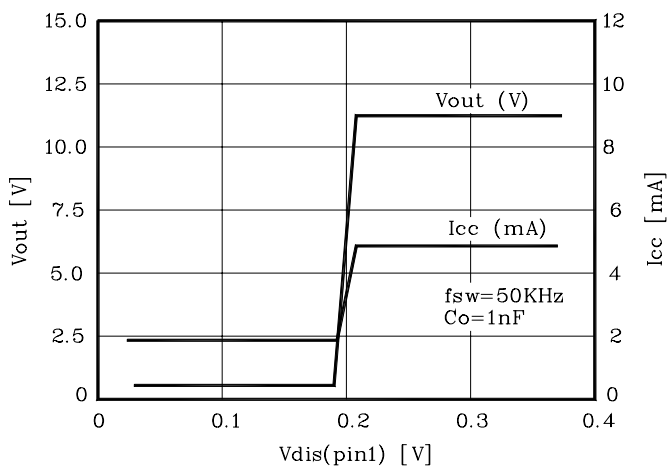
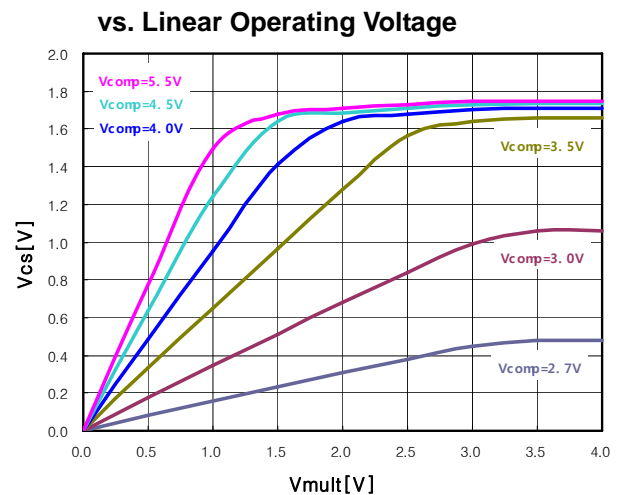
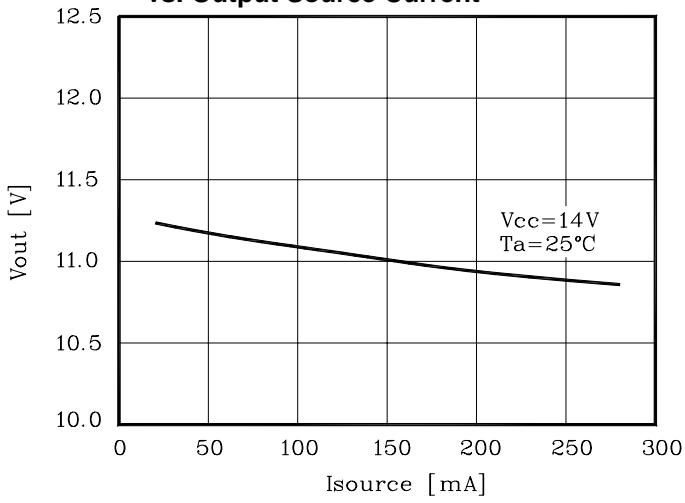

Fig.6 Reference Clamp Voltage



**Fig.7 Output High Voltage vs. Output Source Current**



**Fig.8 Output Low Voltage vs. Output Sink Current**

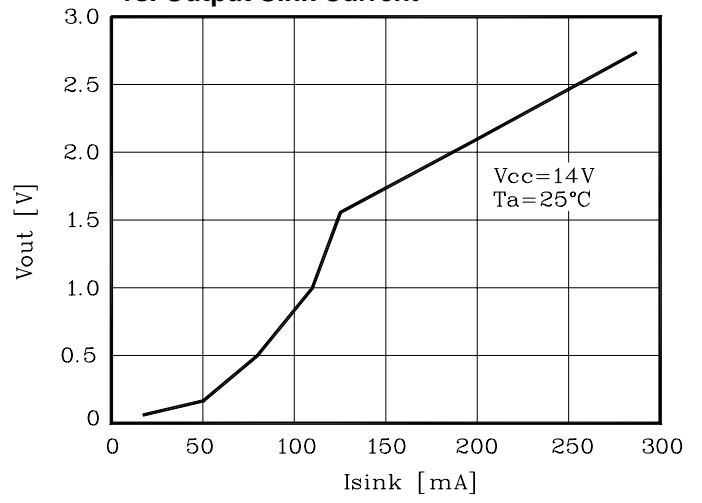

**Fig.9 Operating Supply Voltage vs. Ambient Temperature**

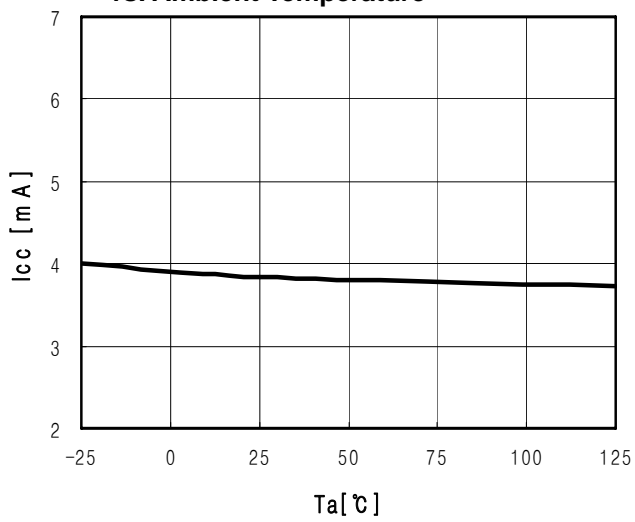

**Fig.10 Multiplier Gain vs. Ambient Temperature**

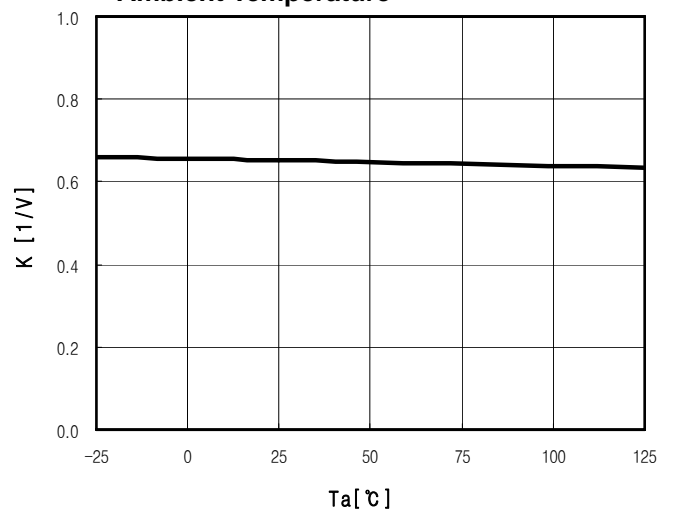

**Fig.11 Output High Voltage vs. Ambient Temperature**

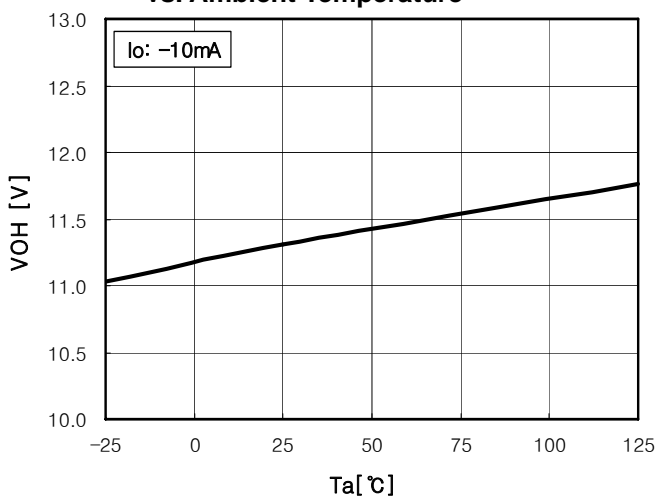

**Fig.12 Output Low Voltage vs. Ambient Temperature**

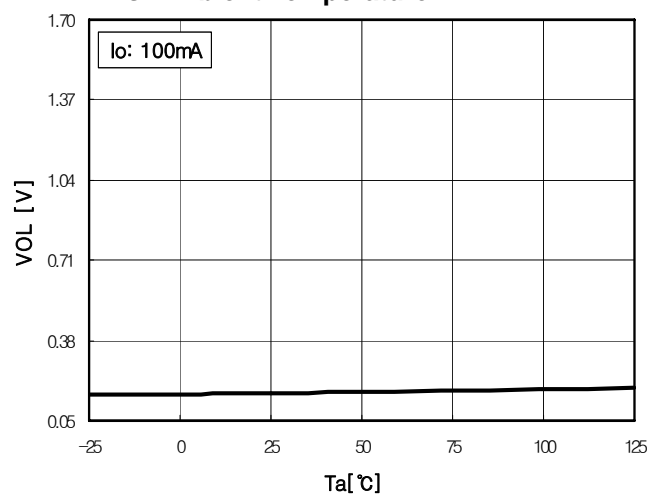

**Fig.13 Output Maximum Slop  
vs. Ambient Temperature**

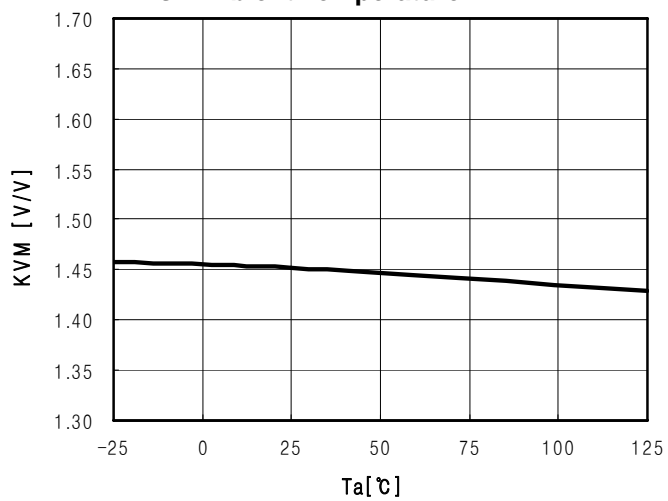

**Fig.14 Input Voltage  
vs. Ambient Temperature**

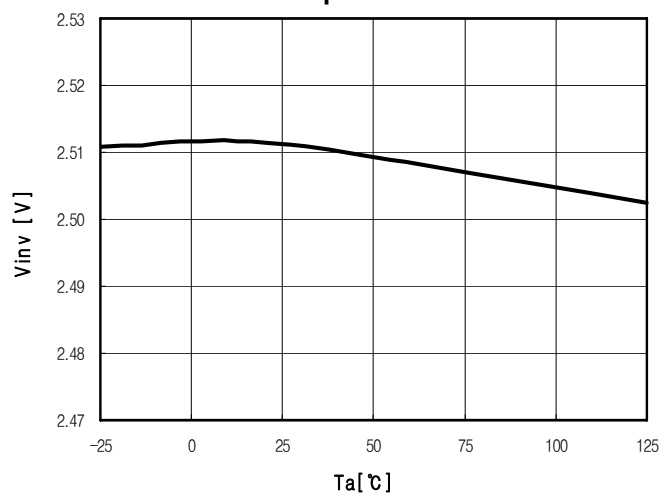

Outline Dimension (Unit : mm)

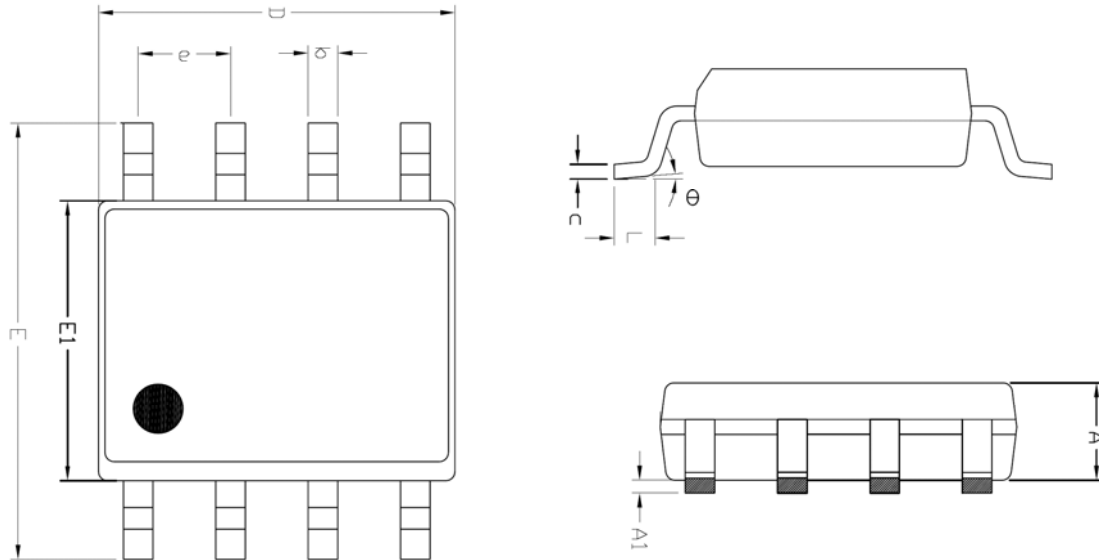

SYMBOL	MILLIMETER(mm)			NOTE
	MINIMUM	NOMINAL	MAXIMUM	
A	1.245	—	1.445	
A1	0.125	0.175	0.275	
b	0.320	0.420	0.520	
c	0.170	0.220	0.270	
D	4.802	4.902	5.002	
E	5.870	6.020	6.170	
E1	3.761	3.861	3.961	
e	1.270 BSC			
L	0.462	0.562	0.662	
$\theta$	0 °	—	8 °	

※ Recommend PCB solder land (Unit : mm)

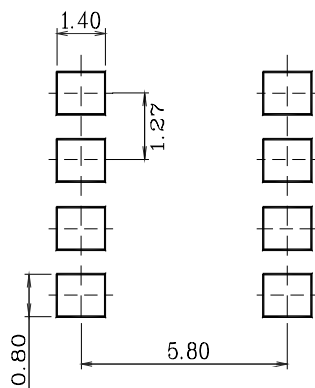

### Outline Dimensions

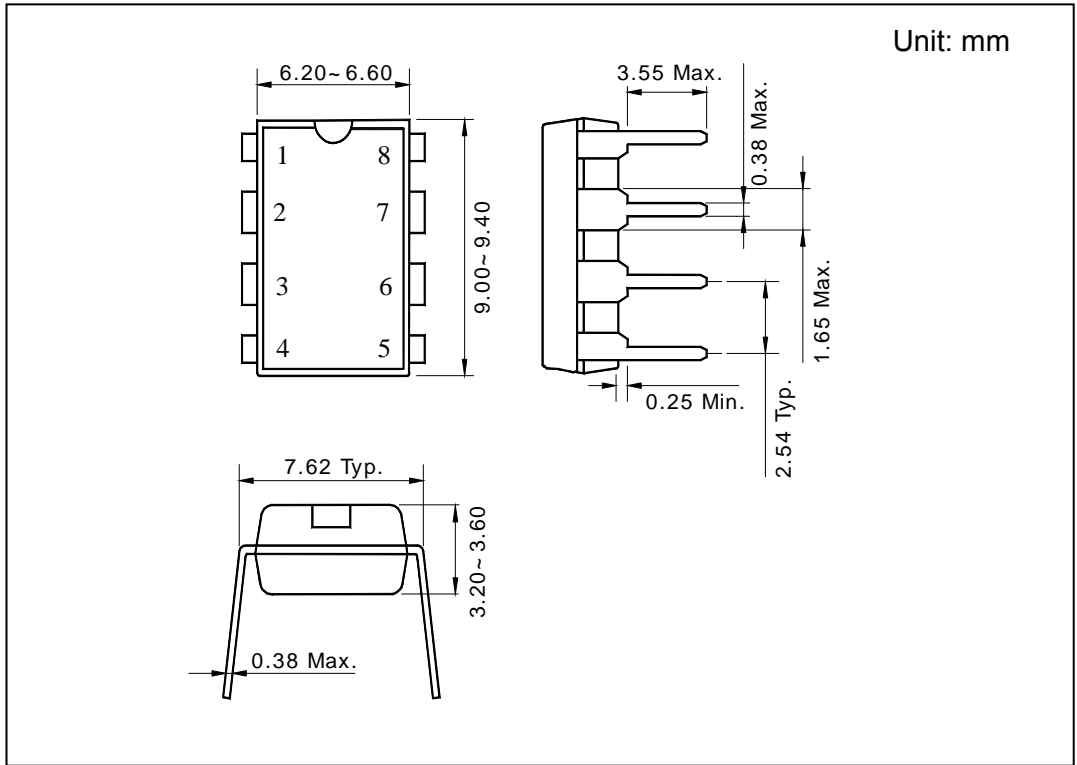

**The AUK Corp. products are intended for the use as components in general electronic equipment (Office and communication equipment, measuring equipment, home appliance, etc.).**

**Please make sure that you consult with us before you use these AUK Corp. products in equipments which require high quality and / or reliability, and in equipments which could have major impact to the welfare of human life(atomic energy control, airplane, spaceship, transportation, combustion control, all types of safety device, etc.). AUK Corp. cannot accept liability to any damage which may occur in case these AUK Corp. products were used in the mentioned equipments without prior consultation with AUK Corp..**

**Specifications mentioned in this publication are subject to change without notice.**