

## Description

S4580 is the dual operational amplifier, specially designed for improving the tone control, which is most suitable for the audio application. Featuring noiseless, higher gain bandwidth, high output current and low distortion ratio, and it is most suitable not only for acoustic electronic parts of audio pre-amp and active filter, but also for the industrial measurement tools. It is also suitable for the head phone amp at higher output current, and further more, it can be applied for the handy type set operational amplifier of general purpose in application of low voltage single supply type which is properly biased of the input low voltage source.

## Features

- Operating voltage. ( $\pm 2V \sim \pm 18V$ )
- Low input noise voltage. ( $0.8 \mu V$  rms typ.)
- Wide gain bandwidth product. (15MHz typ.)
- Low distortion. (0.0005% typ.)
- Slew rate. ( $5V/\mu s$  typ.)

## Ordering Information

Type NO.	Marking	Package Code
S4580	S4580	SOP-8

## Block Diagram

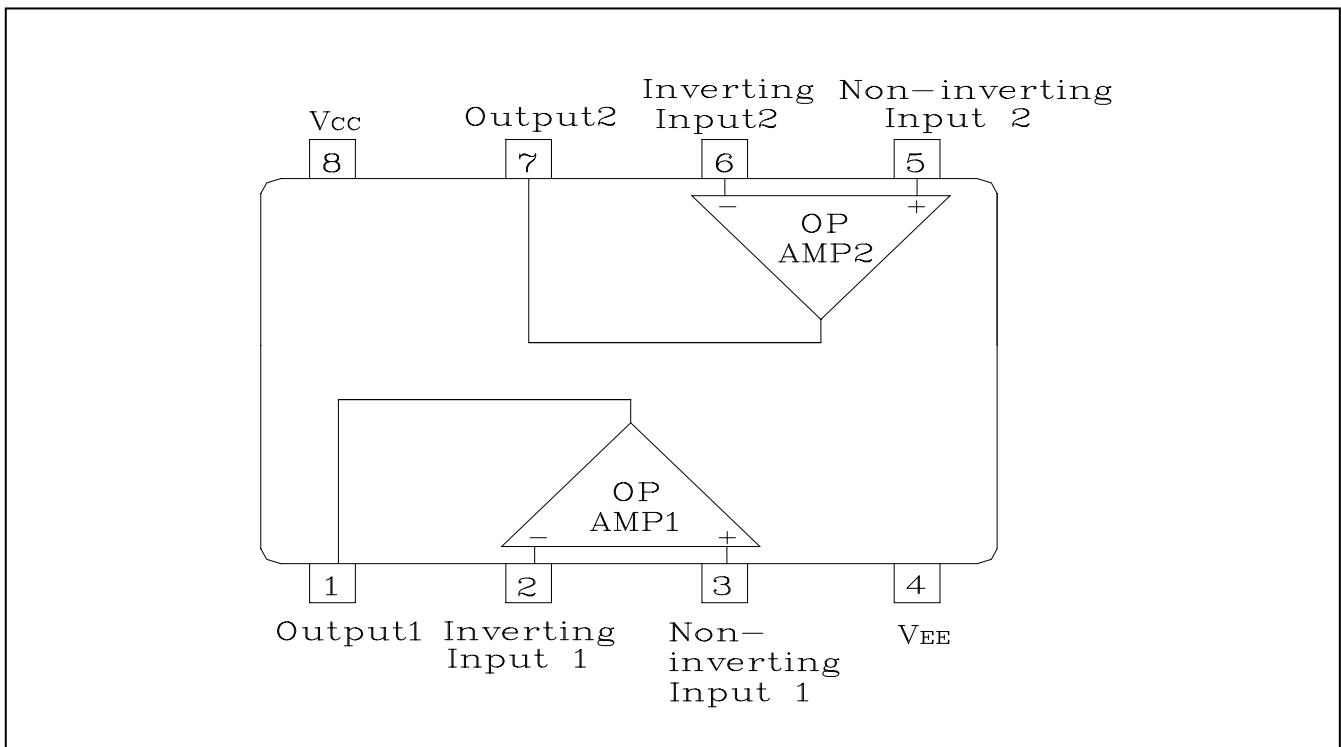

## Absolute maximum ratings

Ta = 25 °C

Characteristic	Symbol	Ratings	Unit
Supply voltage	V <sub>CC</sub>	±18 / 32	V
Differential input voltage	V <sub>ID</sub>	±30	V
Input voltage	V <sub>IC</sub> (note)	±15	V
Output current	I <sub>O</sub>	±50	mA
Power Dissipation	P <sub>D</sub>	300	mW
Operating temperature	T <sub>opr</sub>	-40 ~ +85	°C
Storage temperature	T <sub>stg</sub>	-40 ~ +125	°C

(note) For supply voltage less than ±15V, the absolute maximum input voltage is equal to the supply voltage.

## Electrical Characteristics

(Unless otherwise specified. V<sub>CC</sub> = +15V, V<sub>EE</sub> = -15V and Ta = 25 °C)

Characteristic	Symbol	Test Condition	Min.	Typ.	Max.	Unit
Input offset voltage	V <sub>IOS</sub>	R <sub>g</sub> ≤ 10 kΩ	-	0.5	3	mV
Input offset current	I <sub>IOS</sub>	-	-	5	200	nA
Input bias current	I <sub>IB</sub>	-	-	100	500	nA
Input common mode Voltage Range	V <sub>ICR</sub>	-	±12	±13.5	-	V
		V <sub>CC</sub> = 10V, V <sub>EE</sub> = GND	7.0	8.0	-	
Maximum Output Voltage	V <sub>OM</sub>	R <sub>L</sub> ≥ 2 kΩ	±12	±13.5	-	V
		V <sub>CC</sub> = 10V, V <sub>EE</sub> = GND, R <sub>L</sub> ≥ 2 kΩ	7.0	8.0	-	
Large signal Voltage Gain	G <sub>V</sub>	V <sub>out</sub> = ±10V, R <sub>L</sub> ≥ 2 kΩ	90	110	-	dB
Common mode rejection ratio	CMRR	R <sub>g</sub> ≤ 10 kΩ	80	110	-	dB
Power supply voltage rejection ratio	PSRR	R <sub>g</sub> ≤ 10 kΩ	80	110	-	dB
Slew Rate	SR	R <sub>L</sub> ≥ 2 kΩ	-	5.0	-	V/us
Supply Current	I <sub>CC</sub>	-	-	6.0	9.0	mA
Equivalent input noise voltage	V <sub>NI</sub>	RIAA, R <sub>S</sub> = 2.2 kΩ, f = 30 kHz LPF	-	0.8	-	uVrms
Total harmonic distortion	THD	A <sub>V</sub> = 20dB, V <sub>O</sub> = 5V, R <sub>L</sub> = 2 kΩ f = 1KHz	-	0.0005	-	%
Gain bandwidth product	GB	f = 10KHz	-	15	-	MHz

(note) [ Condition : V<sub>CC</sub> = 10V, V<sub>EE</sub> = GND, R<sub>L</sub> ≥ 2 kΩ, V<sub>IN</sub> Offset = 5V ]

V<sub>OUT</sub> Swing Range [ Typ. 1.0V~9.0V(V<sub>OM</sub> = 8.0V), Min. 1.5V~8.5V(V<sub>OM</sub> = 7.0V) ]

V<sub>ICR</sub> Swing Range [ Typ. 1.0V~9.0V(V<sub>ICR</sub> = 8.0V), Min. 1.5V~8.5V(V<sub>ICR</sub> = 7.0V) ]

## Electrical Characteristic Curves

**Fig. 1  $G_V - f$**

( $V_{CC}/V_{EE} = \pm 15V$  or  $V_{CC}/V_{EE} = 30V / GND$ ,  $R_L = 2 k\Omega$ ,  $40dB_{Amp}$ ,  $T_a = 25^\circ C$ )

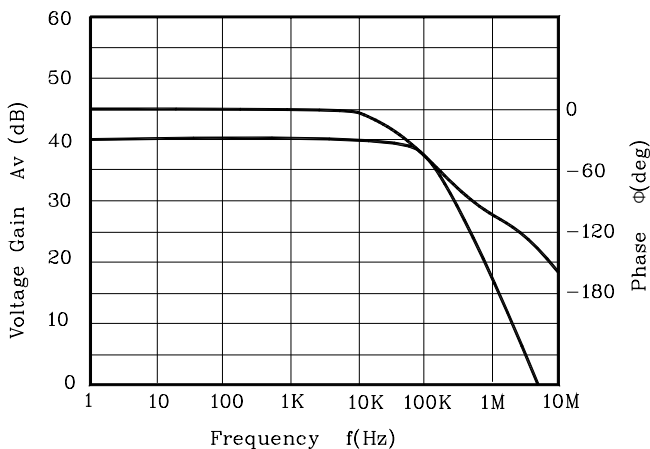

**Fig. 2  $V_{OP-P} - f$**

( $V_{CC}/V_{EE} = \pm 15V$  or  $V_{CC}/V_{EE} = 30V / GND$ ,  $R_L = 2 k\Omega$ ,  $T_a = 25^\circ C$ )

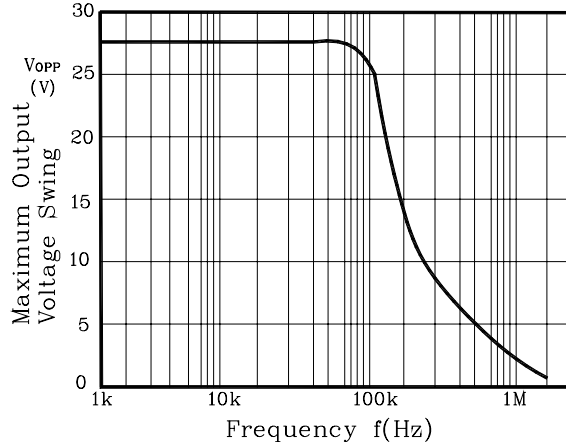

**Fig. 3  $I_B - T_a$**

( $V_{CC}/V_{EE} = \pm 15V$ )

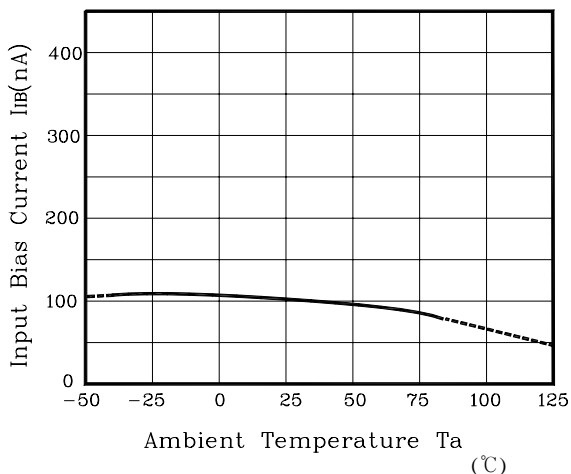

**Fig. 4  $V_{OM} - V_{CC}/V_{EE}$**

( $R_L = 2 k\Omega$ ,  $T_a = 25^\circ C$ )

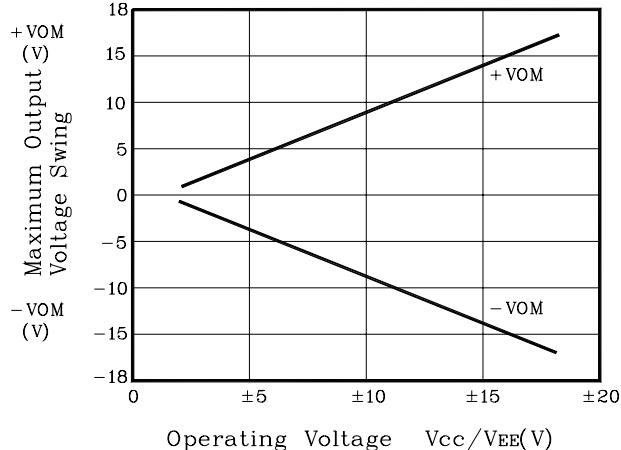

**Fig. 5  $V_{OM} - R_L$**

( $V_{CC}/V_{EE} = \pm 15V$ ,  $T_a = 25^\circ C$ )

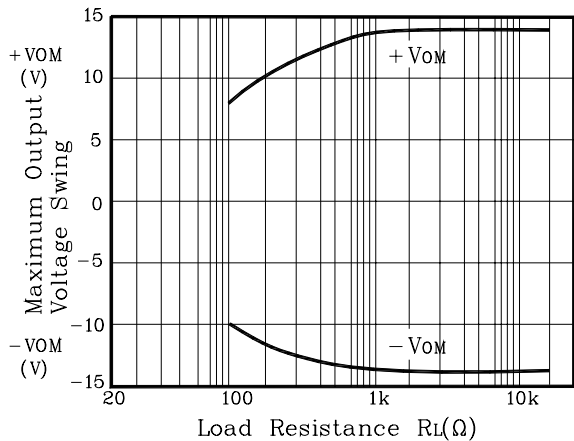

**Fig. 6  $E_N - f$**

( $V_{CC}/V_{EE} = \pm 15V$ ,  $R_S = 50 k\Omega$ ,  $A_v = 60dB$ ,  $T_a = 25^\circ C$ )

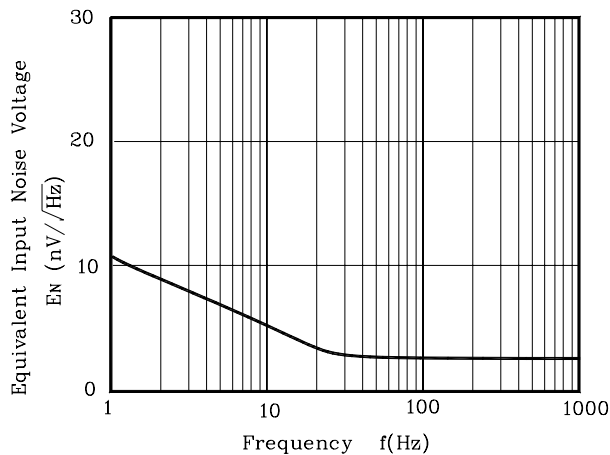

Electrical Characteristic Curves

Fig. 7  $V_{OM} - T_a$

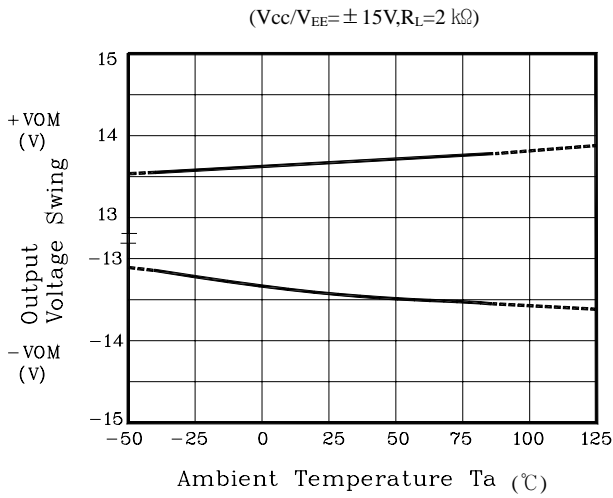

Fig. 8  $I_{CC} - T_a$

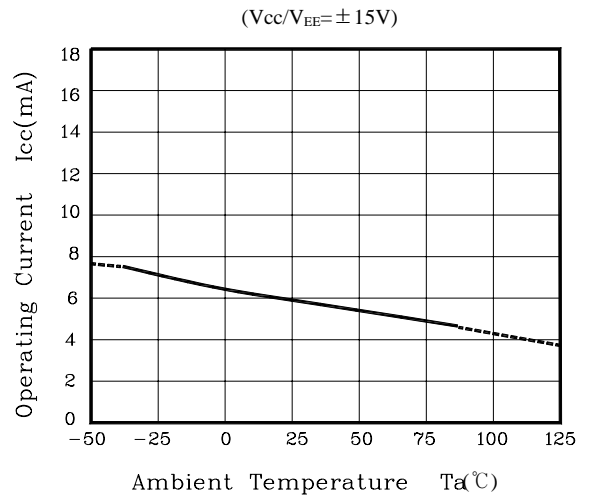

Fig. 9  $V_{IOS} - T_a$

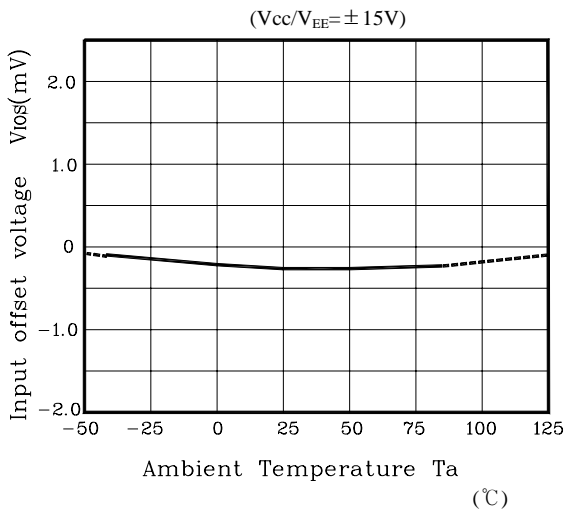

Fig. 10  $I_{CC} - V_{CC}$

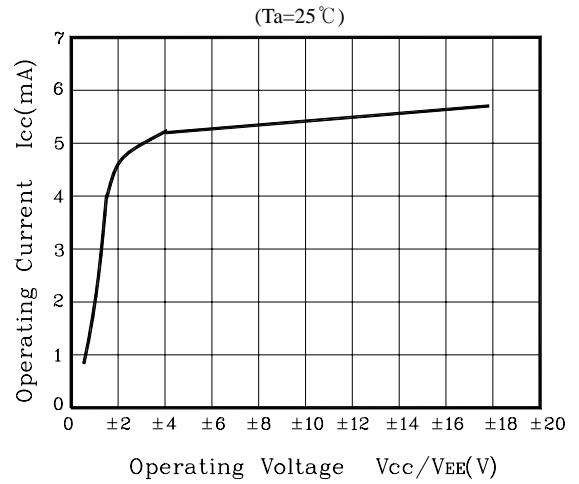

Fig. 11  $V_{IOS} - T_a$

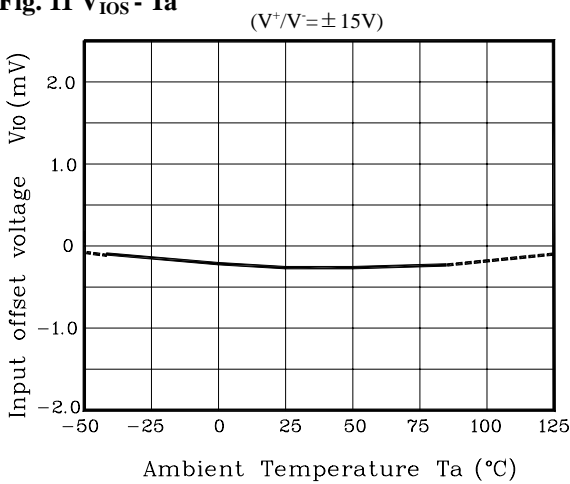
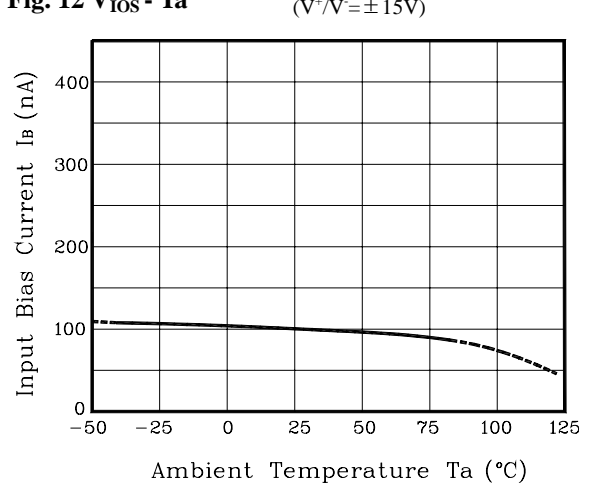

Fig. 12  $V_{IOS} - T_a$



## Electrical Characteristic Curves

Fig. 13  $V_{OM} - T_a$

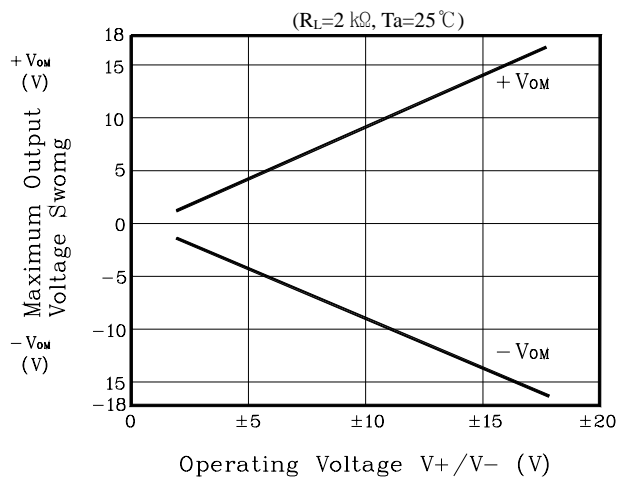

Fig. 10  $I_{CC} - V_{CC}$

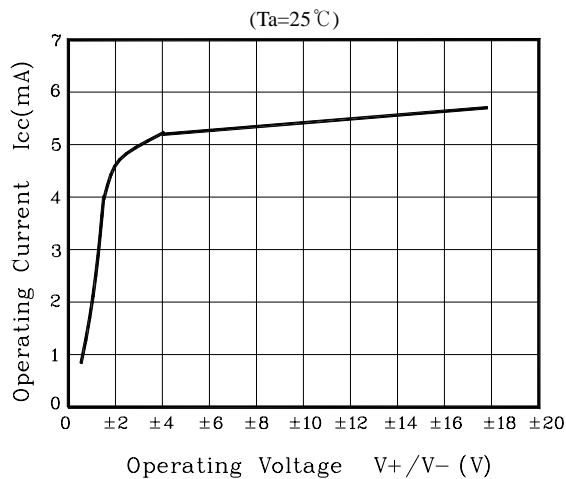

Fig. 15  $V_{IOS} - T_a$

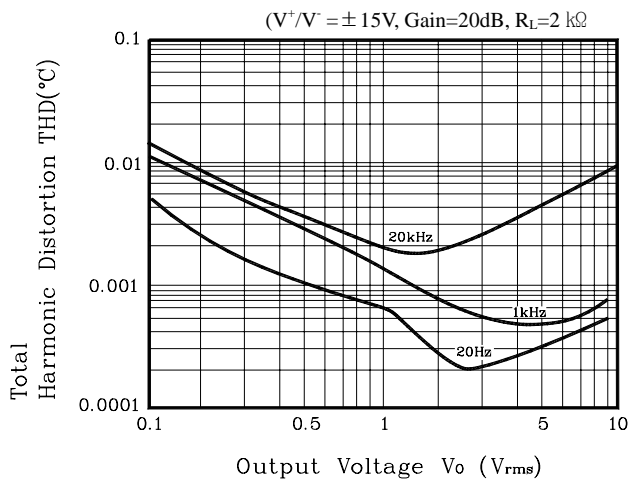
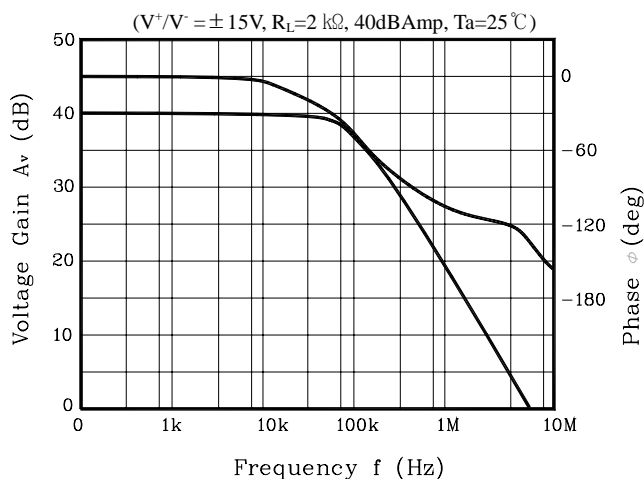
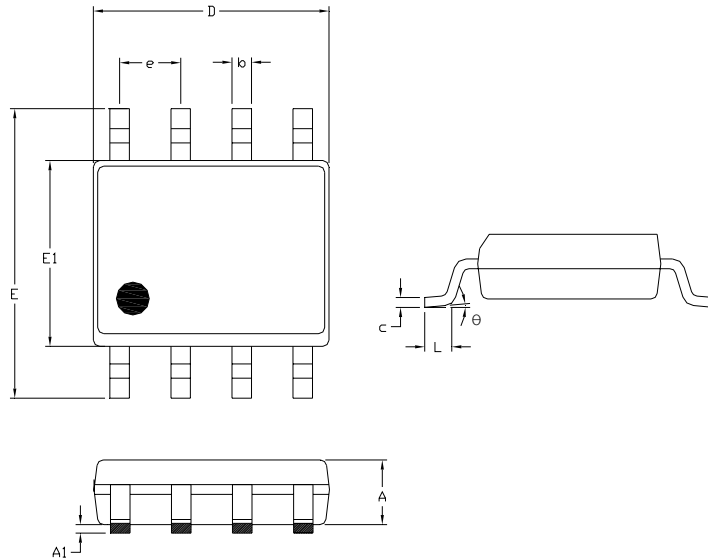

Fig. 16  $I_{CC} - V_{CC}$



Package Dimension [Unit : mm]



SYMBOL	MILLIMETER(mm)		
	MIN	NOM	MAX
A	1.350	1.550	1.750
A1	0.100	—	0.250
b	0.360	0.460	0.506
c	0.15	0.20	0.30
D	4.720	4.920	5.120
E	5.700	6.000	6.300
E1	3.750	3.950	4.150
e	1.270 BSC		
L	0.30	0.50	0.70
$\theta$	0 °	—	8 °

Recommend PCB solder land [SOP-8 / Unit : mm]

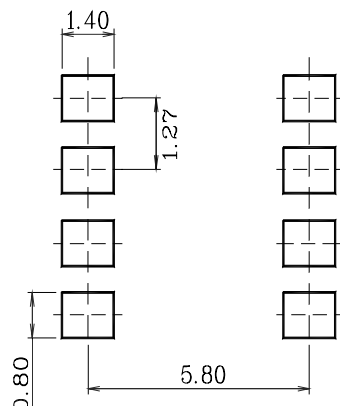

**The AUK Corp. products are intended for the use as components in general electronic equipment (Office and communication equipment, measuring equipment, home appliance, etc.).**

**Please make sure that you consult with us before you use these AUK Corp. products in equipments which require high quality and / or reliability, and in equipments which could have major impact to the welfare of human life(atomic energy control, airplane, spaceship, transportation, combustion control, all types of safety device, etc.). AUK Corp. cannot accept liability to any damage which may occur in case these AUK Corp. products were used in the mentioned equipments without prior consultation with AUK Corp..**

**Specifications mentioned in this publication are subject to change without notice.**