

Semiconductor

http:// www.auk.co.kr

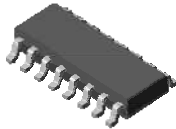

SOP-16

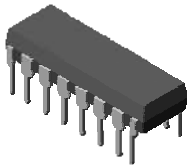

DIP-16

ORDERING INFORMATION

Product	Marking	Package
S377x	S377x	SOP-20
S377xP	S377xP	DIP-18

▲ Marking Detail Information

S377x....[1]

YWW....[2]

[1] Device Code [x: Item Code]

[2] Year & Week Code

Description

The S377x Series are high-voltage, high-current Darlington transistor arrays. Each consists of seven NPN Darlington pairs that feature high-voltage outputs with common-cathode clamp diodes for switching inductive loads. The collector-current rating of a single Darlington pair is 500mA. The Darlington pairs can be paralleled for higher current capability. Applications include relay drivers, hammer drivers, lamp drivers, display drivers (LED and gas discharge), line drivers, and logic buffers.

Application

- ◆ Relay Controller
- ◆ Lamp and Display LED Driver
- ◆ Motor Driver

Features and Benefits

- ◆ Output Current (single output) 500mA(Max.)
- ◆ High sustaining voltage output
- ◆ Output clamp diode
- ◆ Inputs compatible with various types of logic
- ◆ Package : SOP-16, DIP-16

Block Diagram & Pin Configuration

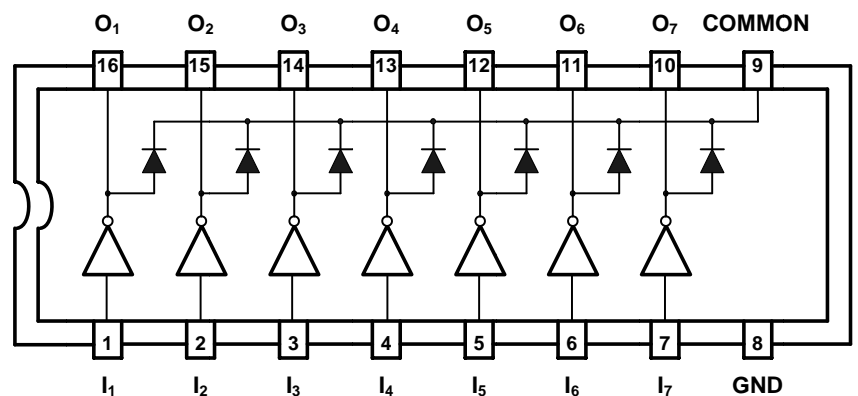

I_x : Input Port

O_x : Output Port

GND : Ground

COMMON : Common

◆ Schematics (Each Driver)

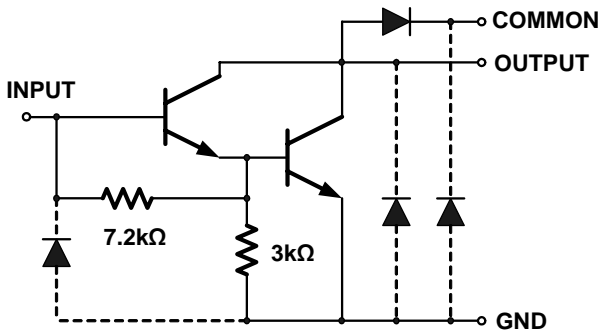

S3771

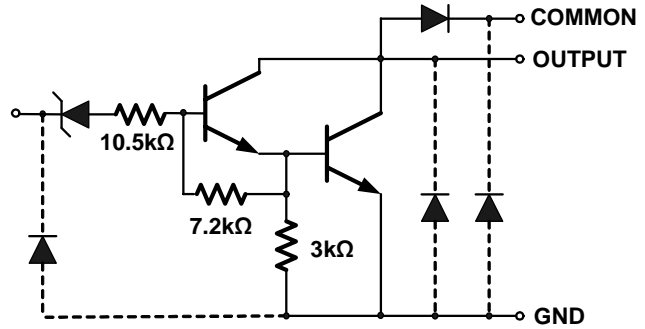

S3772

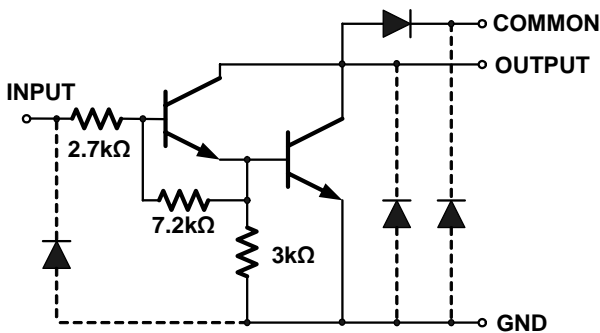

S3773

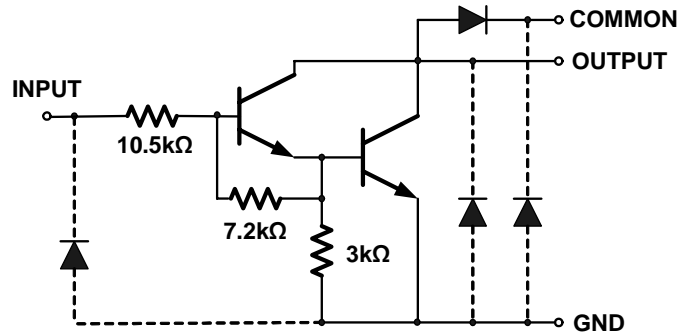

S3774

◆ Product Line-up

Product Name	Input Bias Resistor	Designation	Operating Temperature	Package
S3771	External	General Purpose	-40~85°C	SOP-16
S3772	7V Zener Diode + 10.5KΩ	14~25V PMOS	-40~85°C	SOP-16
S3773	2.7KΩ	TTL, 5V CMOS	-40~85°C	SOP-16
S3774	10.5KΩ	6~15 PMOS, CMOS	-40~85°C	SOP-16
S3771P	External	General Purpose	-40~85°C	DIP-16
S3772P	7V Zener Diode + 10.5KΩ	14~25V PMOS	-40~85°C	DIP-16
S3773P	2.7KΩ	TTL, 5V CMOS	-40~85°C	DIP-16
S3774P	10.5KΩ	6~15 PMOS, CMOS	-40~85°C	DIP-16

◆ Absolute Maximum Ratings (Ta = 25°C)

Parameter	Symbol	Rating		Unit
		SOP-16	DIP-16	
Output Sustaining Voltage	V _{IN}	-0.5~50		V
Output Current	I _{OUT}	500		mA / ch
Input Voltage*	V _{IN}	-0.5~30		V
Input Current**	I _{IN}	25		mA
Clamp Diode	Reverse Voltage	V _R	50	V
	Forward Current	I _F	500	mA
GND Terminal Current	I _{GND}	2.8		A
Power Dissipation	P _d	0.54	1.47	W
Junction Temperature	T _J	150		°C
Operate Temperature Range	T _{opr}	-40 ~ +85		°C
Storage Temperature Range	T _{stg}	-55 ~ +150		°C

*(Except S3771/P), **(Only S3771/P)

◆ Recommended Operating Conditions (Ta=-40~85°C)

Characteristic	Symbol	Test Condition	Min.	Typ.	Max.	Unit	
Output Sustaining Voltage	V _{CE(SUS)}	-	0	-	50	V	
Output Current	I _{OUT}	TPW=25ms, DF=10%, 7 Circuits	0	-	400	mA	
		TPW=25ms, DF=30%, 7 Circuits	0	-	200		
Input Voltage	V _{IN}	Except S3771/P	0	-	30	V	
Input Current	I _{IN}	Only S3771/P	0	-	5	mA	
Clamp Diode Reverse Voltage	V _R	-	-	-	50	V	
Clamp Diode Forward Current	I _F	-	-	-	400	mA	
Power Dissipation	DIP-16	P _D	Ta = 85°C	-	-	0.6	W
	SOP-16		Ta = 85°C*	-	-	0.32	

*(On glass epoxy PCB (30 x 30 x 1.6mm Cu50%)

◆ **Electrical characteristics** (Ta=-40~85°C; unless otherwise specified)

Characteristic		Symbol	Test Circuit	Test Condition	Min.	Typ.	Max.	Unit
Output Leakage Current		I _{CEX}	1	V _{CE} =50V, Ta=25°C	-	-	50	uA
				V _{CE} =50V, Ta=85°C	-	-	100	
	S3772/P			V _{CE} =50V, V _{IN} =6V	-	-	500	
	S3774/P			V _{CE} =50V, V _{IN} =1V	-	-	500	
Collector – Emitter Saturation Voltage		V _{CE(SAT)}	2	I _{OUT} =350mA, I _{IN} =500uA	-	1.3	1.6	V
				I _{OUT} =200mA, I _{IN} =350uA	-	1.1	1.3	
				I _{OUT} =100mA, I _{IN} =250uA	-	0.9	1.1	
Input Current	S3772/P	I _{IN(ON)}	3	V _{IN} =17V	-	0.82	1.25	mA
	S3773/P			V _{IN} =3.85V	-	0.93	1.35	
	S3774/P			V _{IN} =5V	-	0.35	0.5	
				V _{IN} =12V	-	1.0	1.45	
		I _{IN(OFF)}	4	I _{OUT} =500uA, Ta=85°C	50	65	-	uA
Input Voltage	S3772/P	V _{IN(ON)}	5	V _{CE} =2V, I _{OUT} =300mA	-	-	13	V
	S3773/P			V _{CE} =2V, I _{OUT} =200mA	-	-	2.4	
				V _{CE} =2V, I _{OUT} =250mA	-	-	2.7	
				V _{CE} =2V, I _{OUT} =300mA	-	-	3.0	
				V _{CE} =2V, I _{OUT} =125mA	-	-	5.0	
				V _{CE} =2V, I _{OUT} =200mA	-	-	6.0	
	S3774/P			V _{CE} =2V, I _{OUT} =275mA	-	-	7.0	
				V _{CE} =2V, I _{OUT} =350mA	-	-	8.0	
DC Current Transfer Ratio		h _{FE}	2	V _{CE} =2V, I _{OUT} =350mA	1000	-	-	
Clamp Diode Reverse Current		I _R	6	V _R =50V, Ta=25°C	-	-	50	uA
				V _R =50V, Ta=85°C	-	-	100	
Clamp Diode Forward Voltage		V _F	7	I _F =350mA	-	-	2.0	V
Input Capacitance		C _{IN}		-	-	15	-	pF
Turn-ON Delay		t _{ON}	8	V _{OUT} =50V, R _L =163Ω, C _L =15pF	-	0.1	-	uS
Turn-OFF Delay		t _{OFF}			-	0.2	-	

Test Circuit

1. I_{CEX}

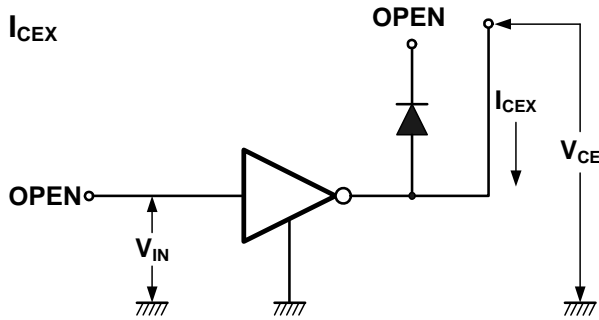

2. $V_{CE(sat)}$, h_{FE}

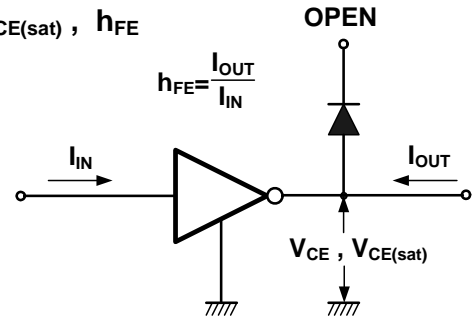

3. $I_{IN(ON)}$

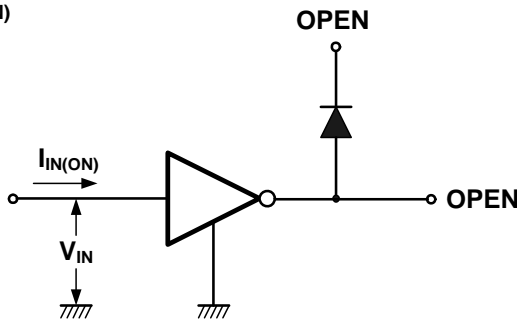

4. $I_{IN(OFF)}$

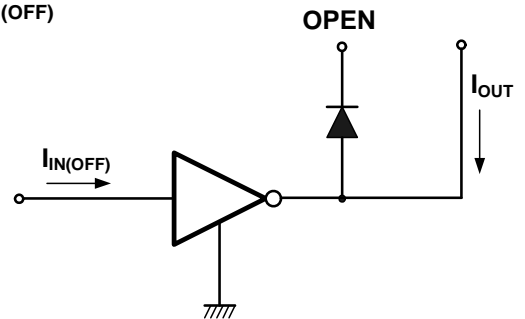

5. $V_{IN(ON)}$

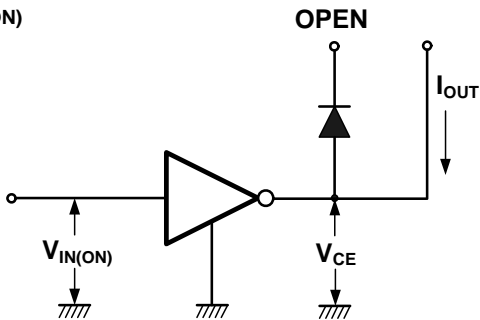

6. I_R

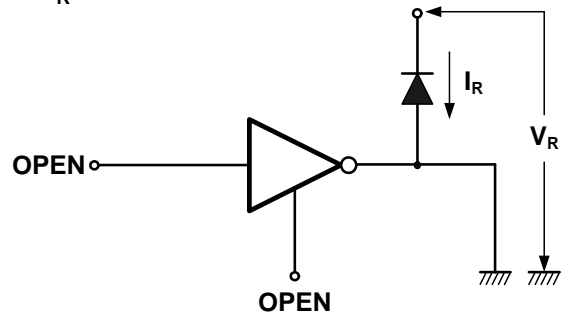

7. V_F

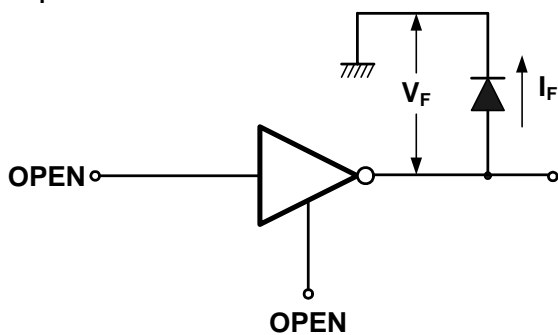

8. t_{ON} , t_{OFF}

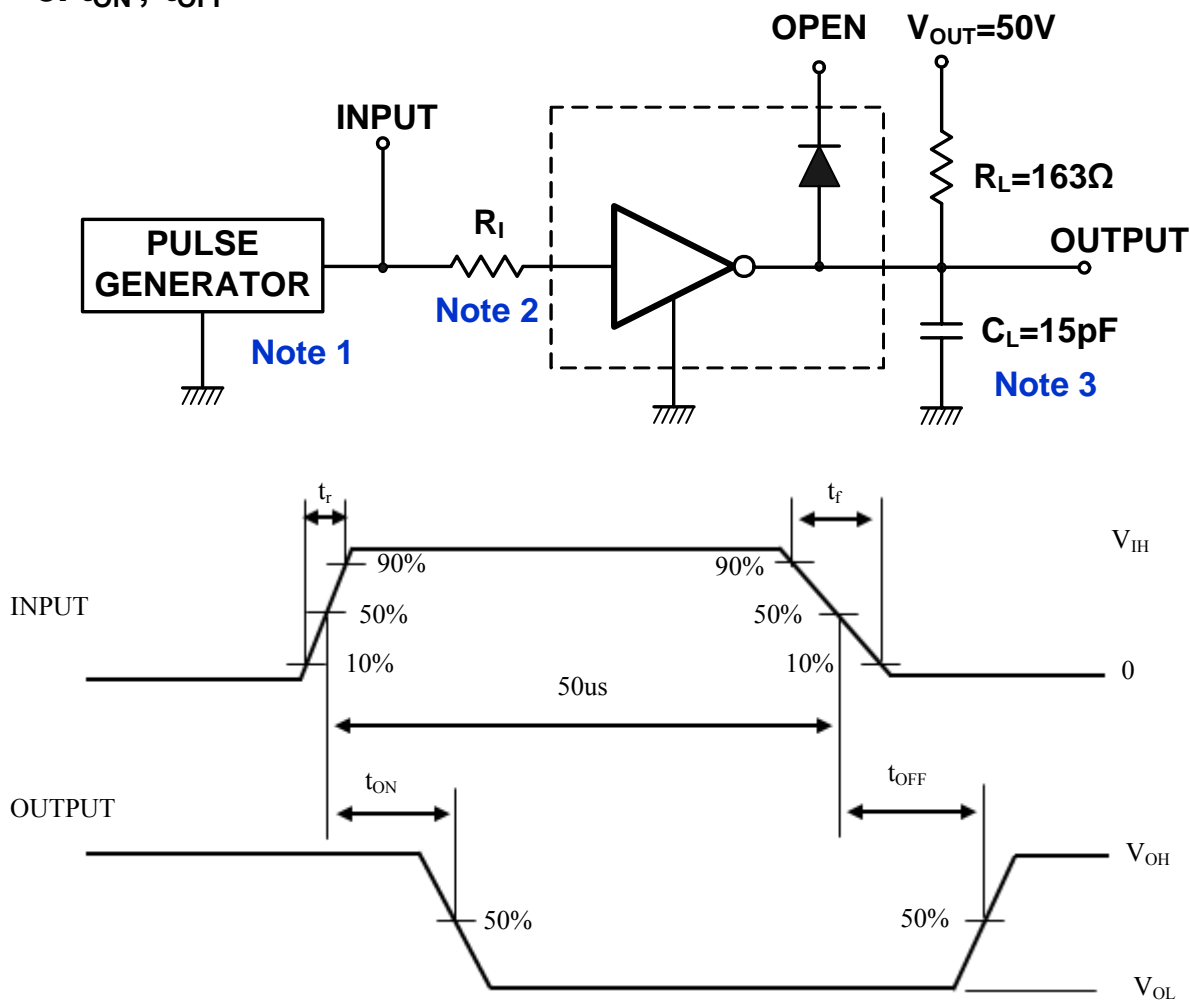

Note 1 : Pulse width 50us, duty cycle 10%

Output impedance 50Ω, $t_r \leq 5ns$, $t_f \leq 10ns$

Note 2 : See below

Input Condition

Item Code	R_I	V_{IH}
S3771/P	2.7KΩ	3V
S3772/P	0	13V
S3773/P	0	3V
S3774/P	0	8V

Note 3 : CL includes probe and jig capacitance

Precautions for using

This IC does not include built-in protection circuits for excess current or overvoltage. If this IC is subjected to excess current or overvoltage, it may be destroyed. Hence, the utmost care must be taken when systems which incorporate this IC are designed. Utmost care is necessary in the design of the output line, COMMON and GND line since IC may be destroyed due to short-circuit between outputs, air contamination fault, or fault by improper grounding.

Application Circuit

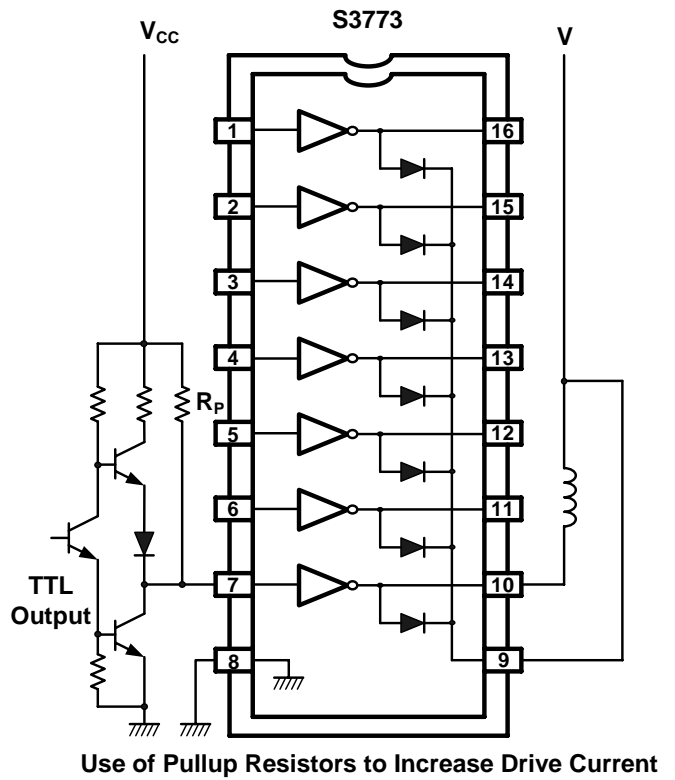
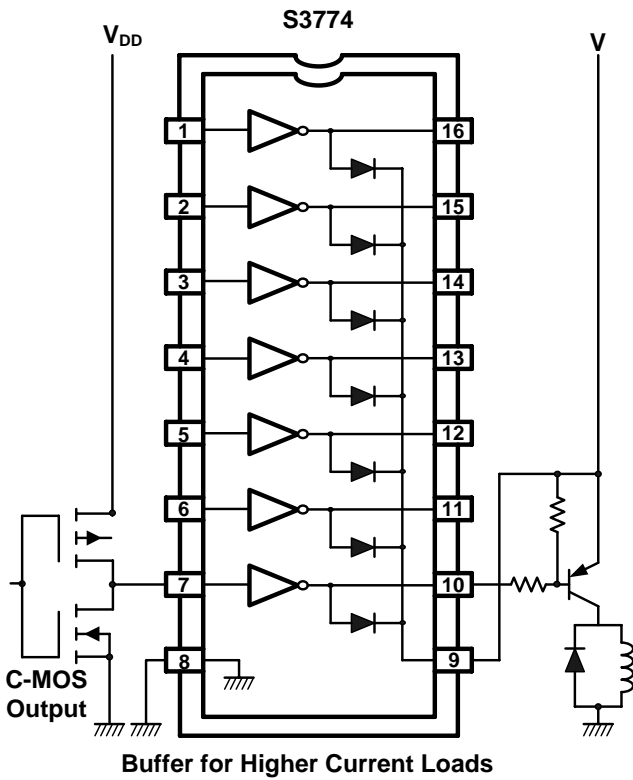
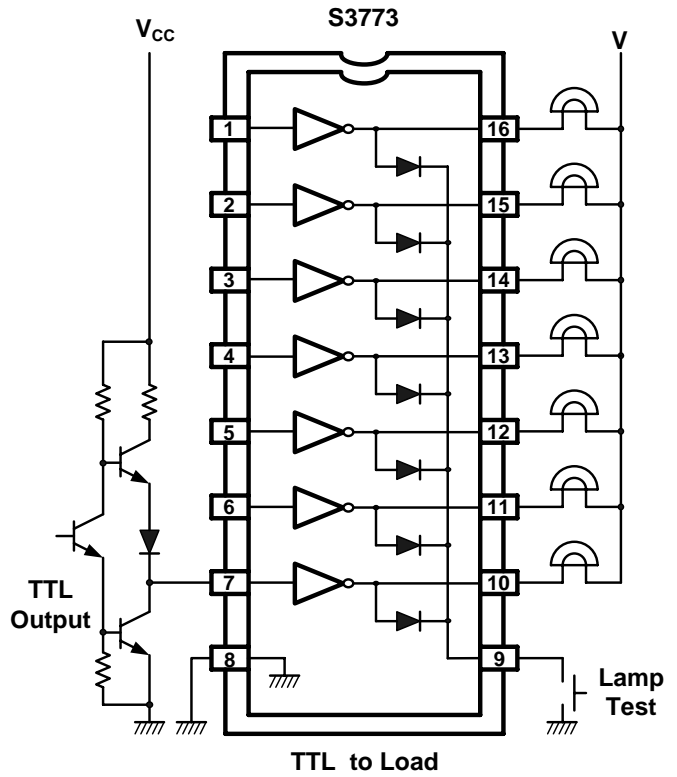
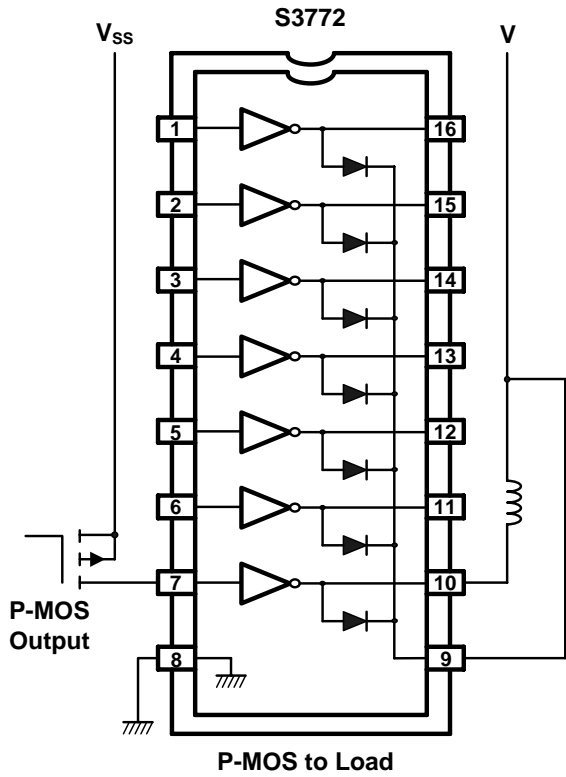

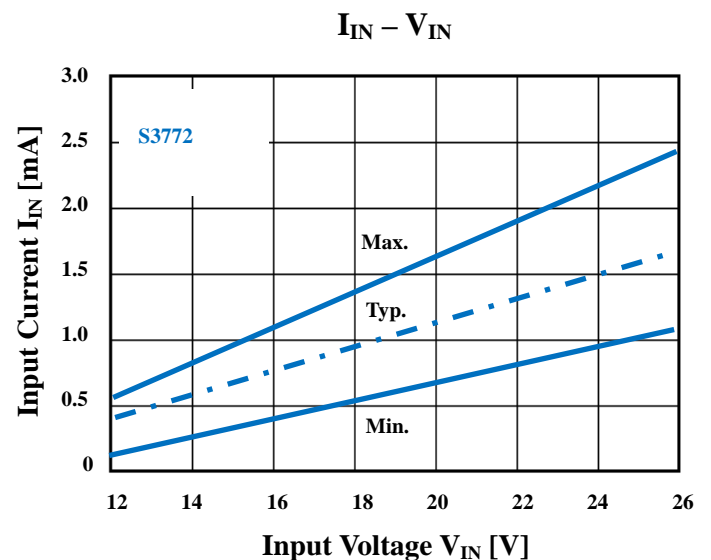
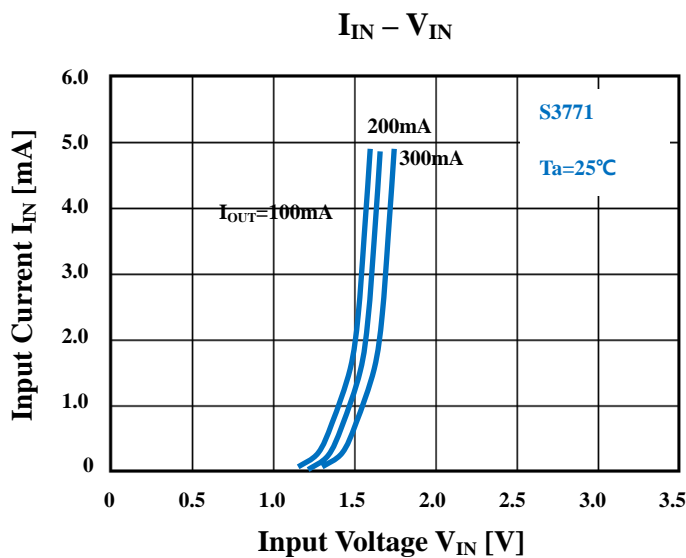
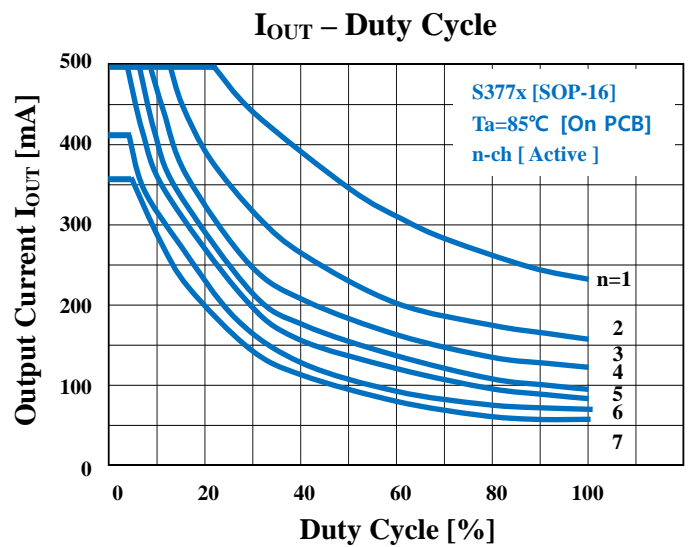
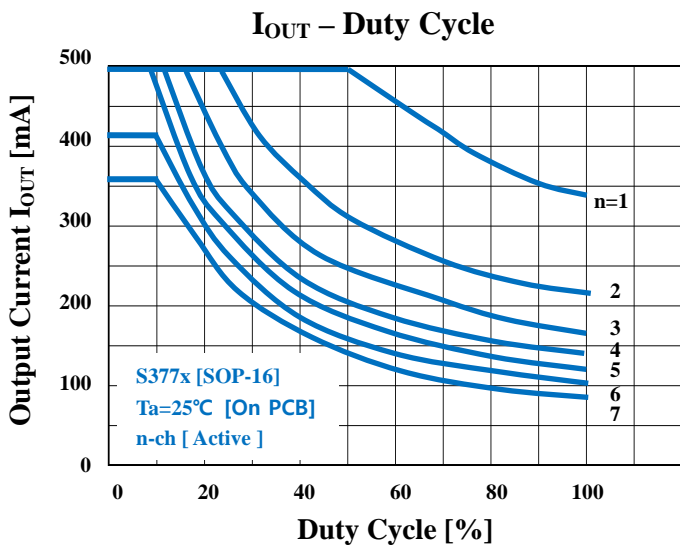
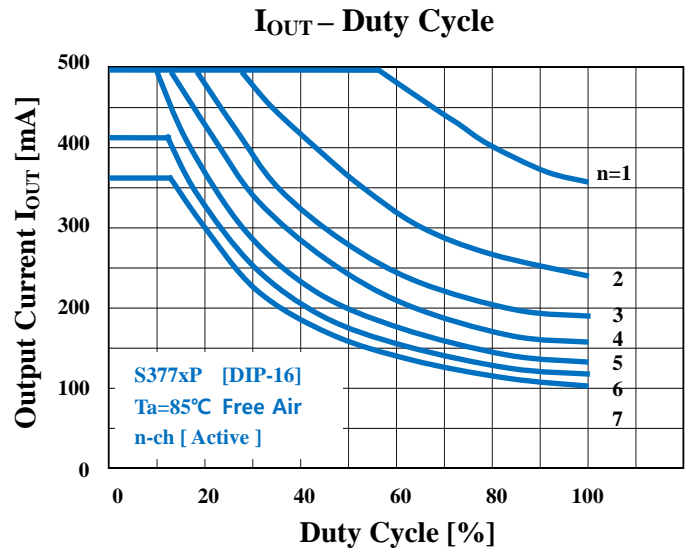
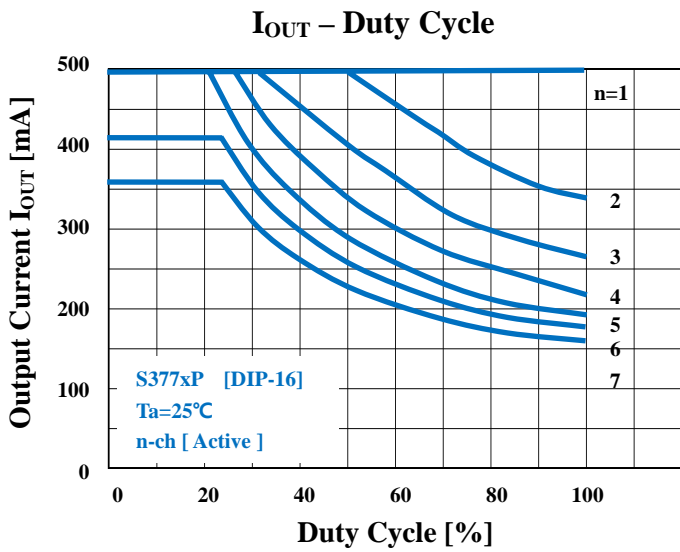

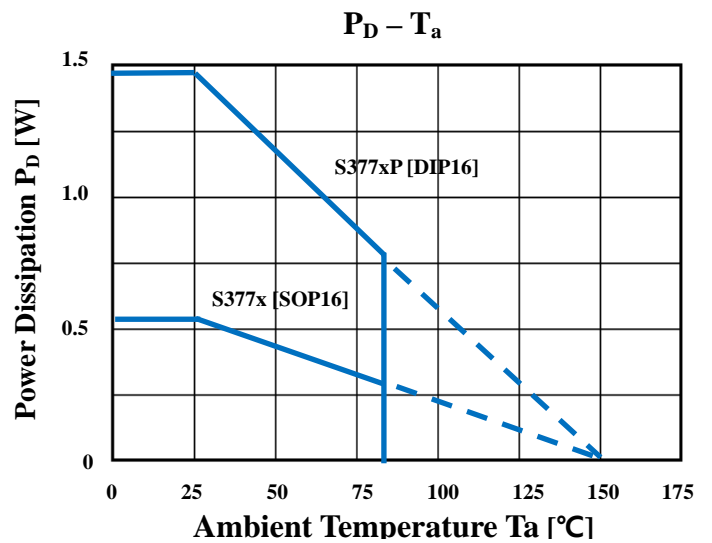
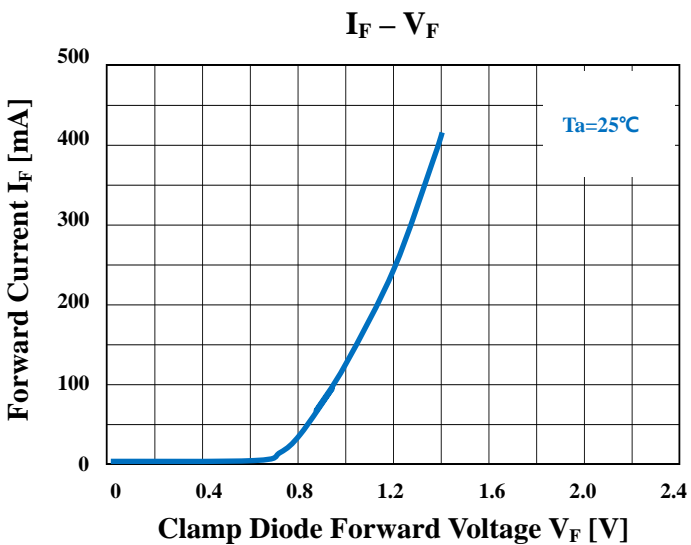
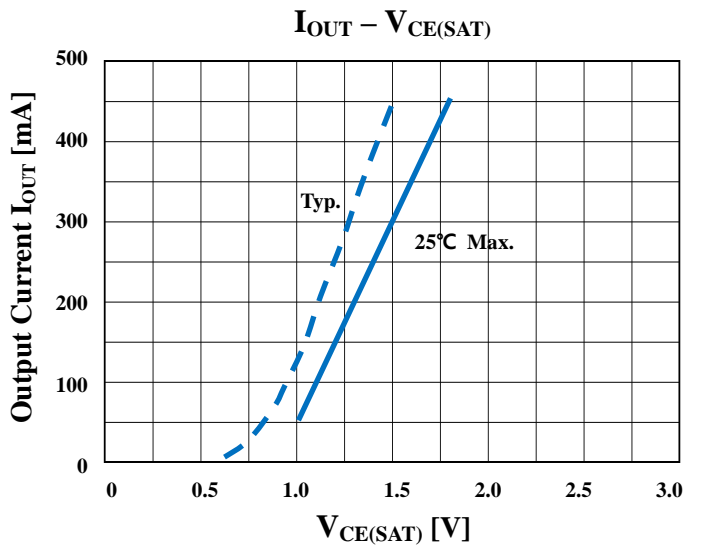
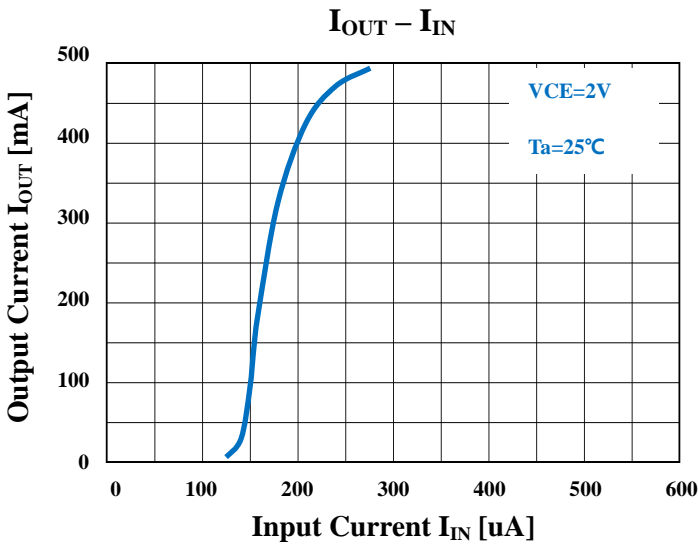
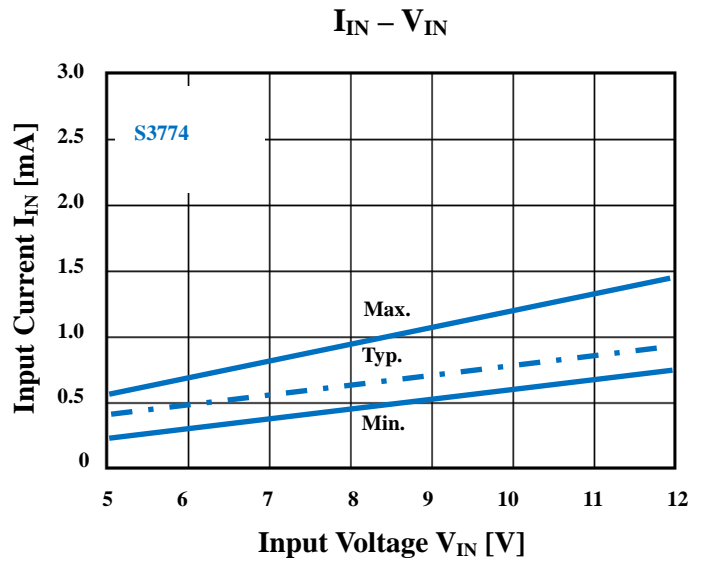
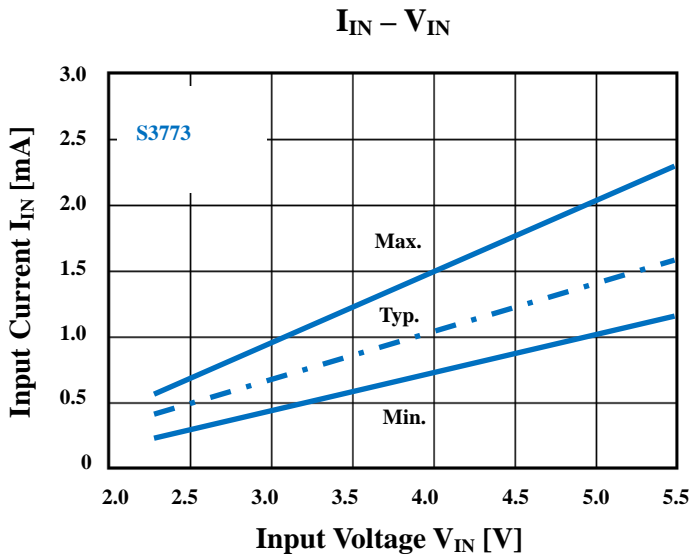

◆ SOP-16 Outline Dimension (Unit : mm)

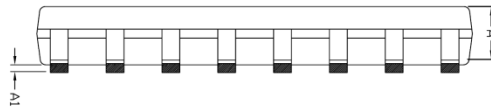
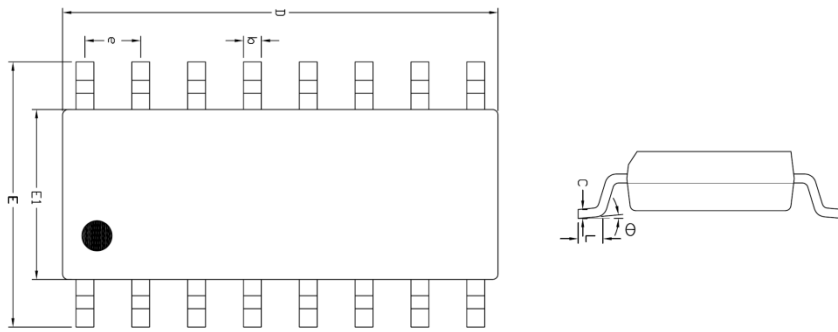

SYMBOL	MILLIMETER(mm)			NOTE
	MINIMUM	NOMINAL	MAXIMUM	
A	1.245	—	1.445	
A1	0.125	0.175	0.275	
b	0.320	0.420	0.520	
c	0.170	0.220	0.270	
D	9.806	9.906	10.006	
E	5.870	6.020	6.170	
E1	3.761	3.861	3.961	
e	1.270 BSC			
L	0.462	0.562	0.662	
θ	0 °	—	8 °	

※ Recommend PCB solder land [Unit: mm]

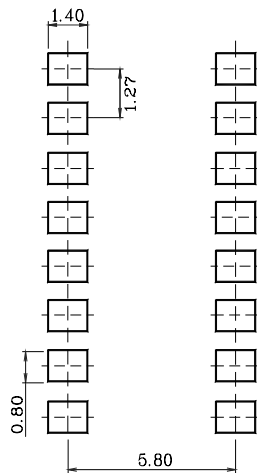

◆ DIP-16(CS) Outline Dimension (Unit : mm)

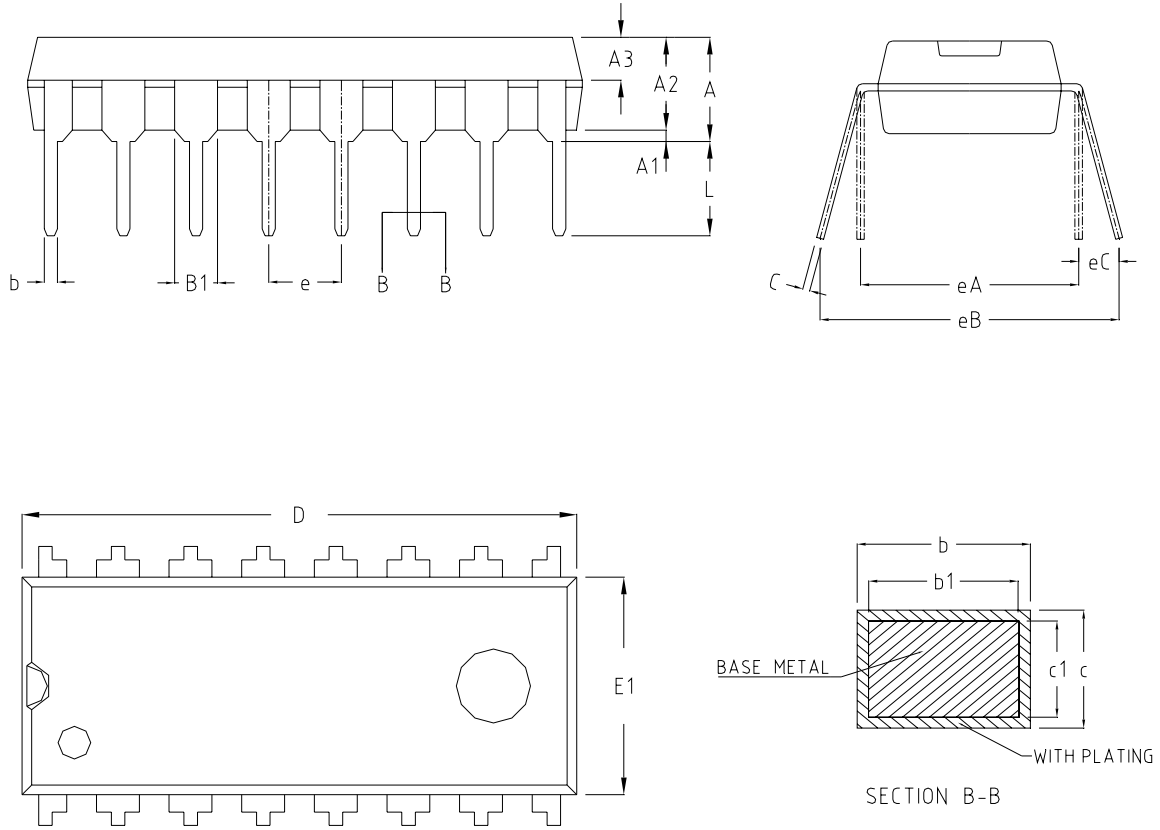

SYMBOL	MILLIMETERS		
	MINIMUM	NOMINAL	MAXIMUM
A	3.60	3.80	4.00
A1	0.51	-	-
A2	3.10	3.30	3.50
A3	1.42	1.52	1.62
b	0.44	-	0.53
b1	0.43	0.46	0.48
B1	1.52BSC		
c	0.25	-	0.31
c1	0.24	0.25	0.26
D	18.90	19.10	19.30
E1	6.15	6.35	6.55
e	2.54BSC		
eA	7.62BSC		
eB	7.62	-	9.50
eC	0	-	0.94
L	3.00	-	-

The AUK Corp. products are intended for the use as components in general electronic equipment (Office and communication equipment, measuring equipment, home appliance, etc.).

Please make sure that you consult with us before you use these AUK Corp. products in equipments which require high quality and / or reliability, and in equipments which could have major impact to the welfare of human life(atomic energy control, airplane, spaceship, transportation, combustion control, all types of safety device, etc.). AUK Corp. cannot accept liability to any damage which may occur in case these AUK Corp. products were used in the mentioned equipments without prior consultation with AUK Corp..

Specifications mentioned in this publication are subject to change without notice.