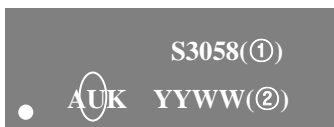

**SSOPH-28N**

With Heat-sink

**ORDERING INFORMATION**

Product Name	Marking	Package Name
S3058	S3058	SSOPH-28N

**▲ Marking Information**

- ① Device Code
- ② Year & Week Code

**Description**

The S3058 is 5 Channel BTL DC motor driver IC for controlling the motors and actuators of CD-P/VCD-P/DVD-Player.

It is organized 2 channel actuator with 2 input OPAMP, 2 channel BTL Driver, 1 channel bi-directional dc motor driver.

Furthermore, it offers gain control pin for bi-directional dc motor driver. It supports various applications with pb free package.

**Application**

- ◆ CAR-Audio
- ◆ CD-Player
- ◆ DVD-Player

**Features and Benefits**

- ◆ 1 Channel is bi-directional DC motor driver for tray.
- ◆ 2 Channels are voltage-type BTL drivers for sled and spindle motors.
- ◆ 2 Channels are voltage-type BTL drivers for actuators with 2 OPAMP
- ◆ Built in Thermal shut down circuit.
- ◆ Built in Mute mode, OVP, UVLO circuit.
- ◆ Built in 2 OP-Amps for Gain Control and noise filtering
- ◆ **Dual Actuator drivers**  
A general purpose input OP Provides differential input for signal addition.  
The output structure is two power OPAMPS in bridge configuration.
- ◆ **Sled motor driver**  
Single input linear BTL driver.  
The output structure are two power OPAMP in bridge configuration.
- ◆ **Spindle driver**  
Single input linear BTL driver.  
The output structure are two power OPAMPS in bridge configuration.
- ◆ **Tray Bi-directional driver**  
The DC motor driver supports forward/reverse control for tray motor.

◆ Internal Block Diagram & Pin Assignment

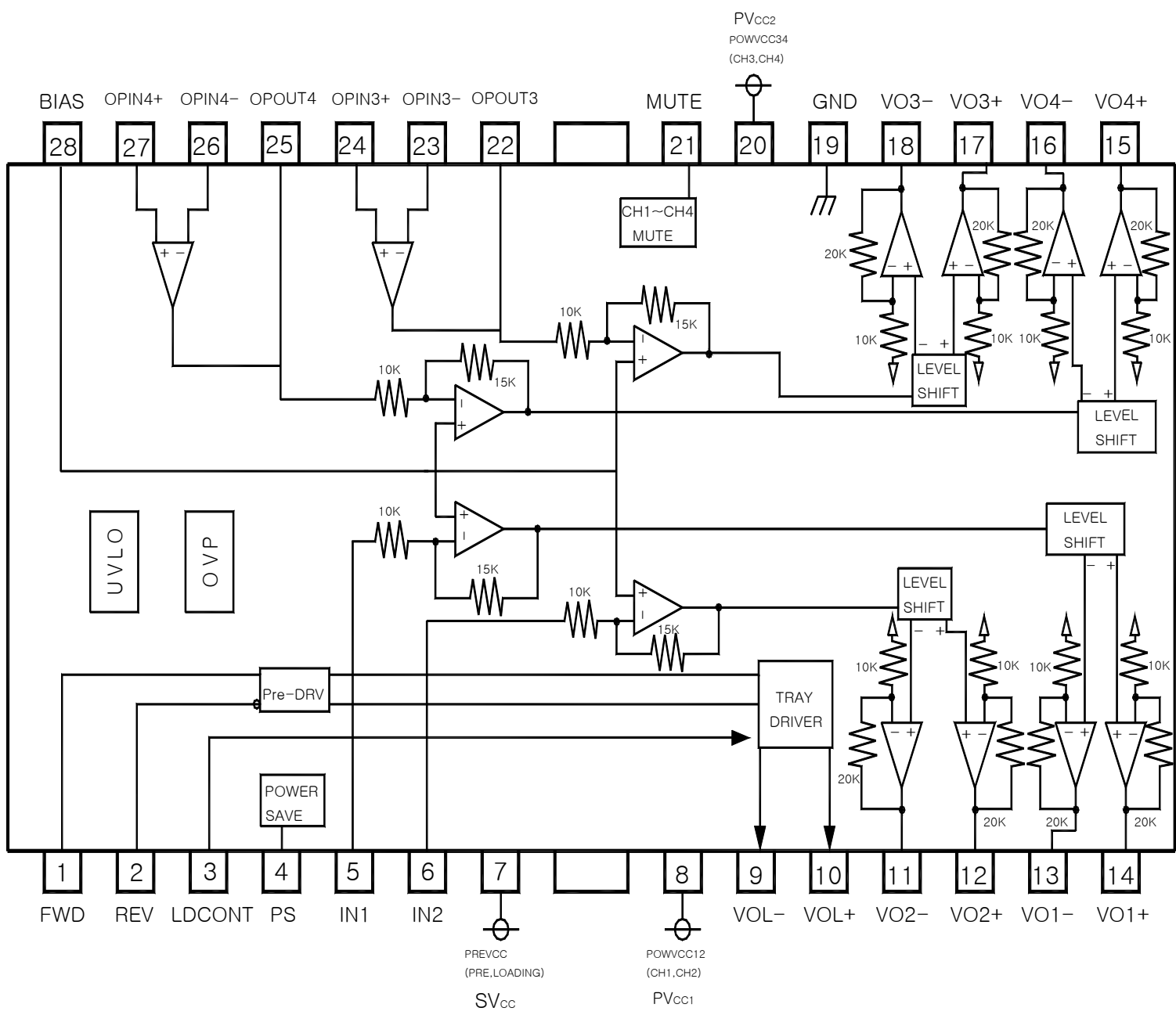

◆ Pin Description

NO	SYMBOL	I/O	DESCRIPTION
1	FWD	I	Tray>Loading) motor forward input
2	REV	I	Tray>Loading) motor reverse input
3	LDCONT	I	Tray>Loading) motor speed control
4	PS	I	Power Save
5	IN1	I	Input for channel 1
6	IN2	I	Input for channel 2
7	SV <sub>CC</sub>	PWR	V <sub>CC</sub> for pre-driver block and power block of Tray
8	PV <sub>CC1</sub>	PWR	V <sub>CC</sub> for power block of channel 1, channel 2
9	VOL-	O	Tray>Loading) driver output (-)
10	VOL+	O	Tray>Loading) driver output (+)
11	VO2-	O	Channel 2 driver output (-)
12	VO2+	O	Channel 2 driver output (+)
13	VO1-	O	Channel 1 driver output (-)
14	VO1+	O	Channel 1 driver output (+)
15	VO4+	O	Channel 4 driver output (+)
16	VO4-	O	Channel 4 driver output (-)
17	VO3+	O	Channel 3 driver output (+)
18	VO3-	O	Channel 3 driver output (-)
19	GND	-	Ground
20	PV <sub>CC2</sub>	PWR	V <sub>CC</sub> for power block of channel 3, channel 4
21	MUTE	I	Input for mute control
22	OPOUT3	O	Channel 3 OPAMP output
23	OPIN3-	I	Channel 3 OPAMP input -
24	OPIN3+	I	Channel 3 OPAMP input +
25	OPOUT4	O	Channel 4 OPAMP output
26	OPIN3-	I	Channel 4 OPAMP input -
27	OPIN3+	I	Channel 4 OPAMP input +
28	BIAS	I	Input for bias control

Symbol of + and - [ output of drives ] means polarity to input/output pin.

◆ Absolute Maximum Ratings (  $T_a = 25^\circ\text{C}$  )

Parameter	Symbol	Limits	Unit
Maximum Supply Voltage	$V_{CC\text{ max}}$	13.5	V
Power Dissipation	$P_d$	1.7	W
Operate Temperature Range	$T_{opr}$	-40 ~ +85	$^\circ\text{C}$
Storage Temperature Range	$T_{stg}$	-55 ~ +150	$^\circ\text{C}$

[  $P_d$  ] When mounted on a 70mm×70mm×1.6mm glass epoxy board.  
 Reduced by 13.6mW for each increase in  $T_a$  of  $1^\circ\text{C}$

[  $T_{stg}$  ] Should not exceed  $P_d$  or SOA and  $T_j=150^\circ\text{C}$  values

◆ Guaranteed Operating Conditions (  $T_a = 25^\circ\text{C}$  )

Parameter	Symbol	Limits	Unit
Power Supply Voltage	$SV_{CC}$	4.3 ~ 13.2	V
	$PV_{CC1}$	4.3 ~ $SV_{CC}$	V
	$PV_{CC2}$	4.3 ~ $SV_{CC}$	V

◆ Power Dissipation Curve [  $P_d$  ]

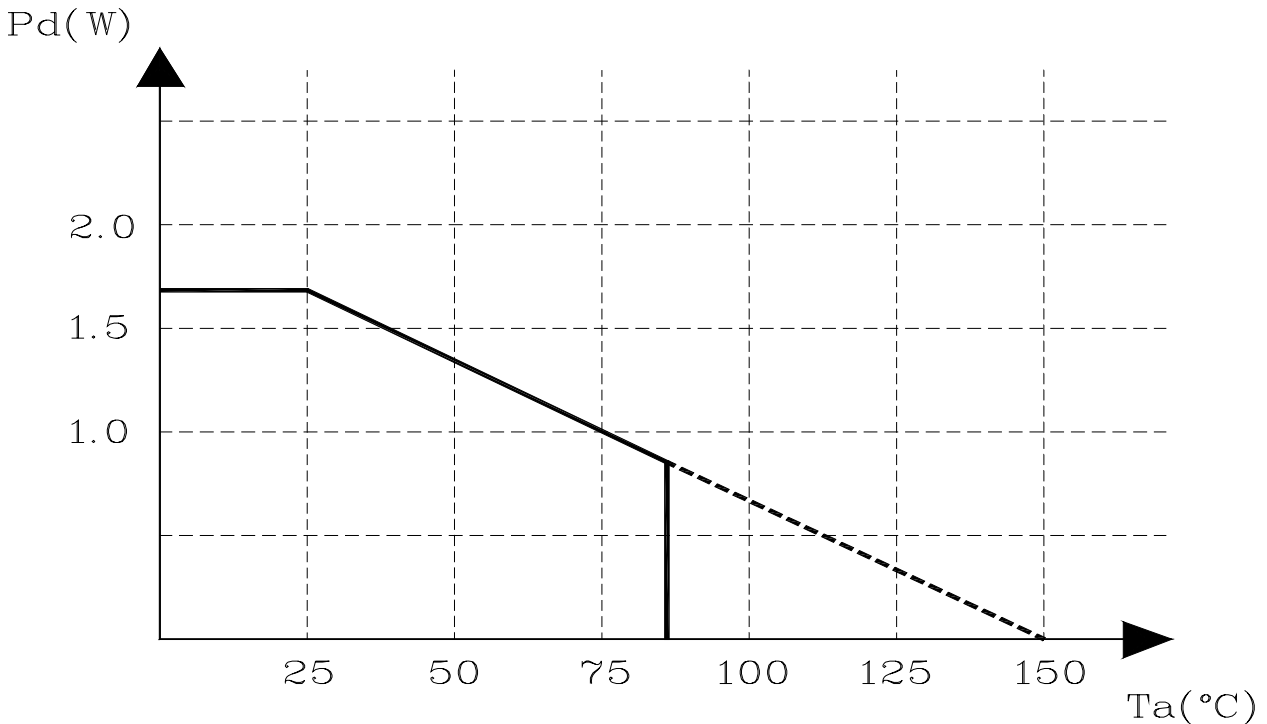

◆ 70mm×70mm×1.6mm glass epoxy board .

◆ De-rating is done at 13.6mW/ $^\circ\text{C}$  for operating above  $T_a=25^\circ\text{C}$

### ◆ Electrical characteristics

( Unless otherwise specified Ta=25 °C, SVcc=12V, PVcc1=PVcc2=5V, BIAS=1.65V, PS=2V, RL=12Ω)

NO	Characteristics	Symbol	Condition	Specification			Unit
				MIN.	TYP.	MAX.	
1	Quiescent current	Iqc	RL = Open	-	23	34	mA
2	Power save on current	Ips	PS = GND	-	1.65	2.8	mA
3	Power save on voltage	Vpson		-	-	0.5	V
4	Voltage for mute off	Vpsoff		2.0	-	-	V
5	Mute on voltage	Vmon		-	-	0.5	V
6	Mute off voltage	Vmoff		1.5	-	-	V
7	Input current for mute pin	Imute		-	200	300	uA
8	Input current for bias pin	Ibias		-	80	120	uA
<b>&lt; BTL Driver Part : Channel 1, 2, 3, 4 &gt;</b>							
9	Output offset voltage	Voo	Vin=Vbias (Channel 1, 2)	-50	-	50	mV
			Vin=Vbias (Channel 3, 4)	-80	-	80	mV
10	Maximum output voltage	Vom	RL=12Ω Load	3.6	4.0	-	V
11	Closed loop voltage gain	Gvc	VIN=BIAS+0.2Vpp ac @1khz	17	19	21	dB
<b>&lt; Input OPAMP Part : Channel 3, 4 &gt;</b>							
12	Common mode input range	Vicm	Vbias=4V	0.5	-	10	V
13	Input bias current	Ibop		-	-	300	nA
14	High level output voltage	Vohop	Vbais=6V	11.5	-	-	V
15	Low level output voltage	Volop	Vbais=6V	-	-	0.5	V
16	Output sink current	Isink		1	-	-	mA
17	Output source current	Isource		1	-	-	mA
18	Slew rate	Srop	Vin=2Vp-p @100KHz	-	1	-	V/us
<b>&lt; Tray&gt;Loading) Motor driver &gt;</b>							
19	Output saturation voltage1	Vsat12 Vsat21	Upper + Lower saturation voltage @ IL= 200mA	0.7	1.1	1.5	V
20	Output saturation voltage Between FWD & REV	ΔVsat1	Vsat12 - Vsat21	-	-	0.1	V
21	Output saturation voltage2	Vsat34 Vsat43	Upper + Lower saturation voltage @ IL= 500mA	1.0	1.55	2.2	V
22	Output adjustable gain on “H” side voltage	Gvh	LDCONT= 2V	7.4	9.2	11	dB
<b>&lt; Tray&gt;Loading) driver input logic &gt;</b>							
23	Input high level voltage	Vihld		1.5	-	Vcc	V
24	Input low level voltage	Villd		-0.3	-	0.5	V
25	Input high level current	Iihld	FWD=REV=5V	-	180	270	uA

**Application Information**

**1] Thermal Shut Down Circuit**

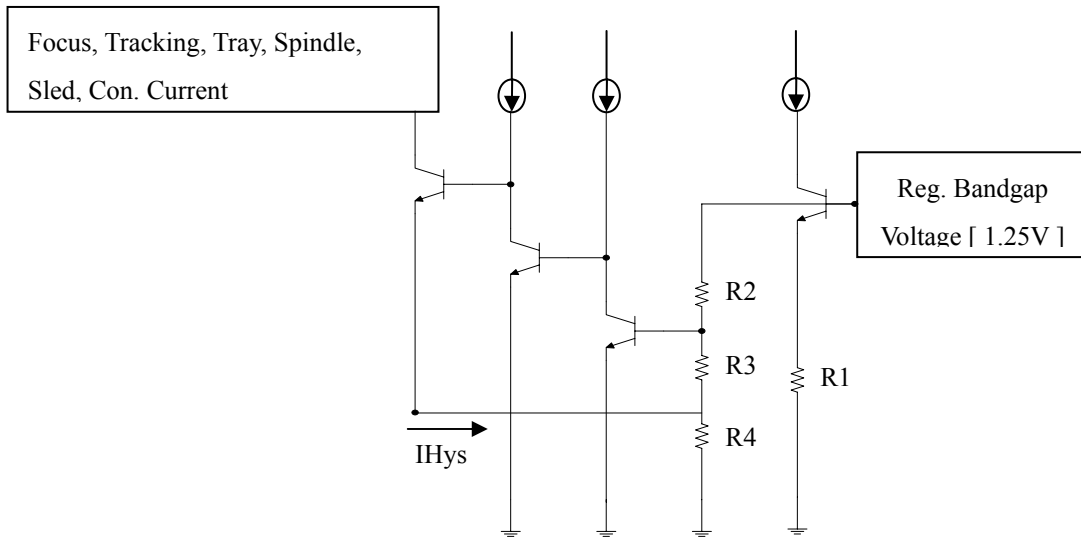

The built-in thermal shutdown circuit mutes the output current when the chip temperature reaches 175°C (typ.). The hysteresis is set to 25°C (typ.) by IHys, so the circuit will start up again when the chip temperature falling to 150°C (typ.)

**2] Bias & Mute Circuit**

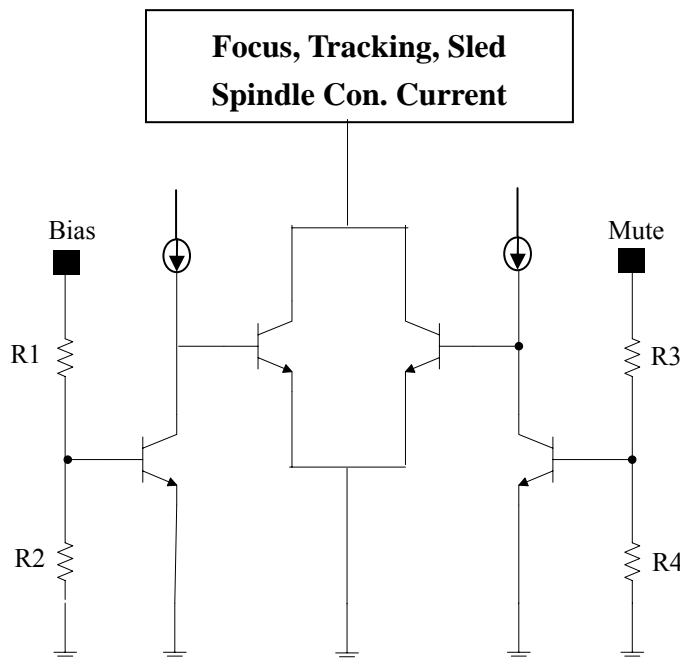

Bias pin (pin 28) should be pulled up to more than 1.2V. In case the bias pin's voltage is pulled down below 1.2V (typ.), the output current is muted, also Mute pin is same as Bias pin.

[Except Tray, Input 2 OPAMP. those are only controlled by SVcc. ]

3] BTL Driver Circuits [Channel 1, 2, 3, 4]

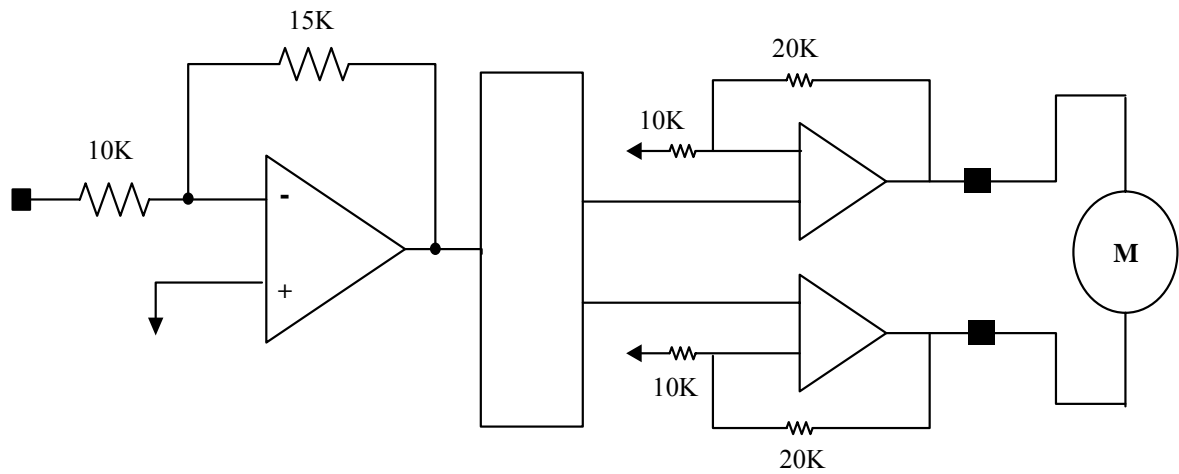

BTL Driver Circuits are composed of VI-Converter, Level Shifter and Output power AMP.

VI-Converter converts voltage of  $V_{in}$  into current [ $I_{conv}$ ]

$$I_{conv} = (V_{in} - Bias) / R1[10K\Omega]$$

► Closed Loop Voltage Gain

$$\begin{aligned} \text{Gain} &= 20 \log [2 \times (15K/10K) \times \{1 + (20K/10K)\}] \\ &= 19.08 \text{ [dB]} \end{aligned}$$

► Gain Control by Using external resistor

$$\text{Gain} = 20 \log [2 \times (15K/R_{ext} + 10K) \times \{1 + (20K/10K)\}]$$

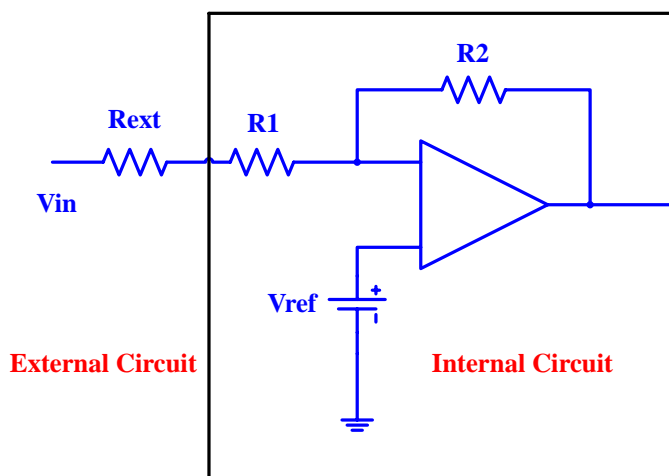

4] Tray driver logic input

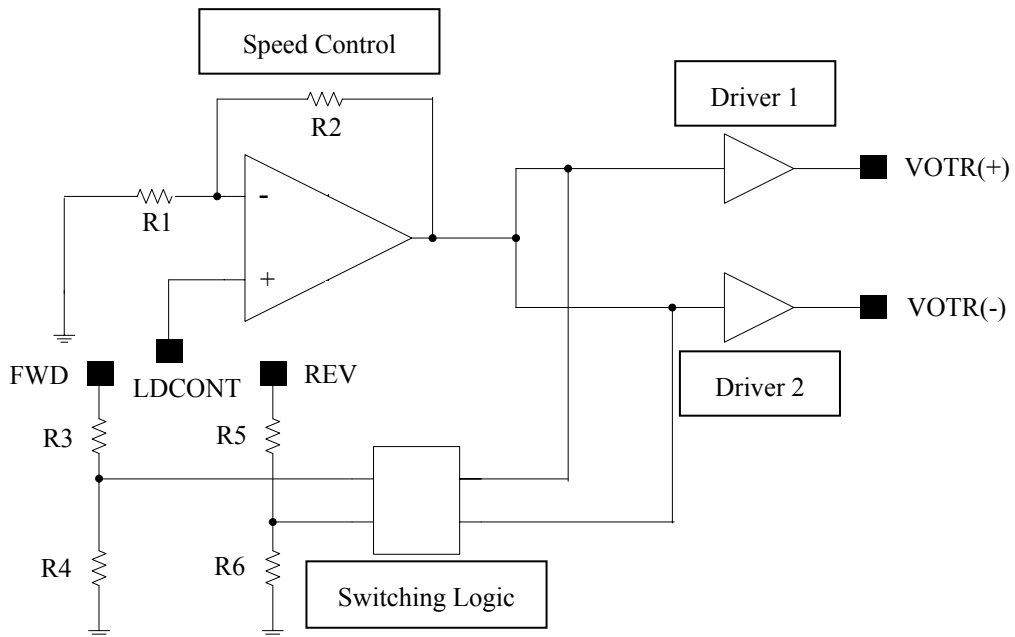

FWD [pin6]	REV [pin7]	VOTR+ [pin10]	VOTR- [pin9]	FUNCTION
L	L	OPEN	OPEN	Open mode
L	H	L	H	Reverse mode
H	L	H	L	Forward mode
H	H	L	L	Brake mode

Input circuit of pin1 [FWD] and pin2 [REV] is designed to avoid simultaneous activation of upper and lower output power TR. however, in order to improve reliability, apply motor forward/reverse input once through open mode. We recommend that the time period of open state is longer than 10msec.

“H” side output voltage on output voltage [VOL+, VOL-] varies depending on output control terminal for tray. [pin3]“H” side output voltage is set three times (9.2dB typ.) LDCONT [pin3], and “L” side output voltage is equal to output saturation voltage.

### Characteristic Diagrams

**Fig. 1 V<sub>CC</sub> - I<sub>QC</sub>**

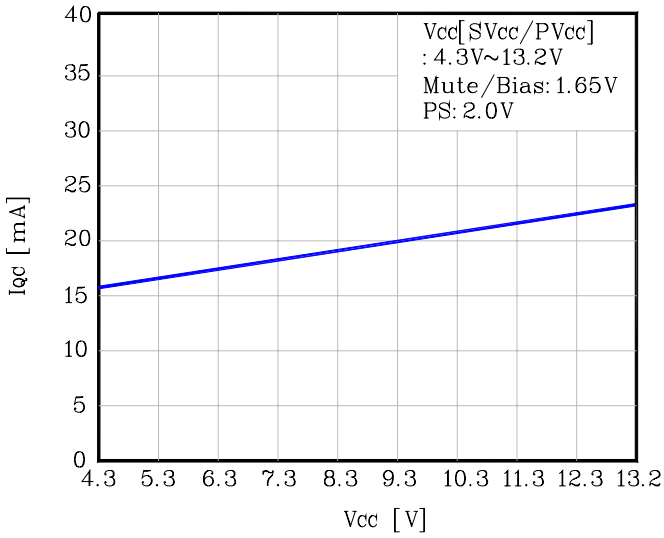

**Fig. 2 Temperature - I<sub>QC</sub>**

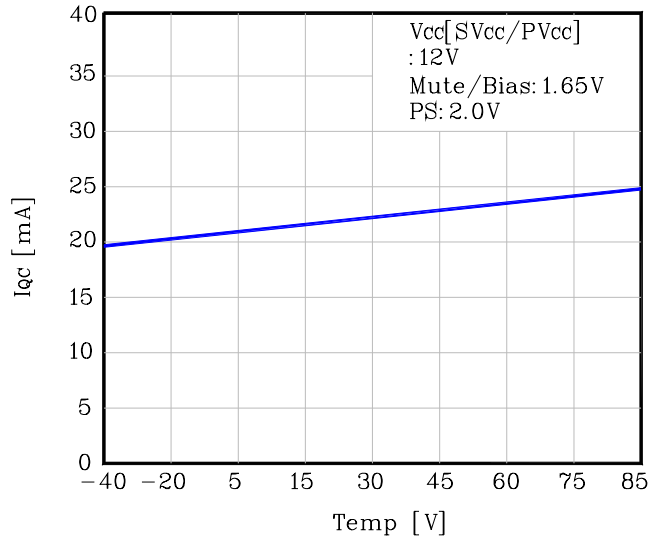

**Fig. 3 V<sub>OM</sub> - V<sub>CC</sub>**

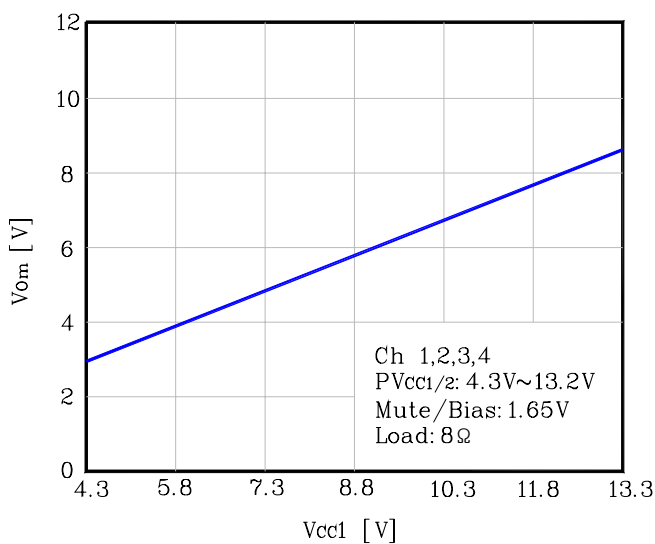

**Fig.4 GV - Frequency**

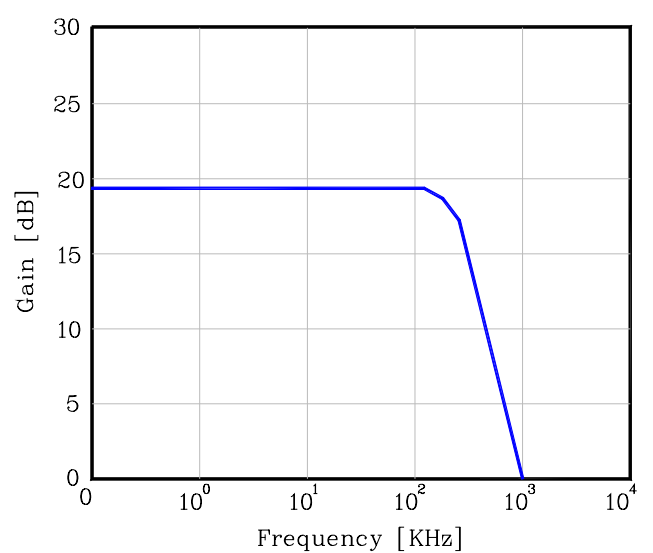

**Fig. 5 Mute Threshold Voltage**

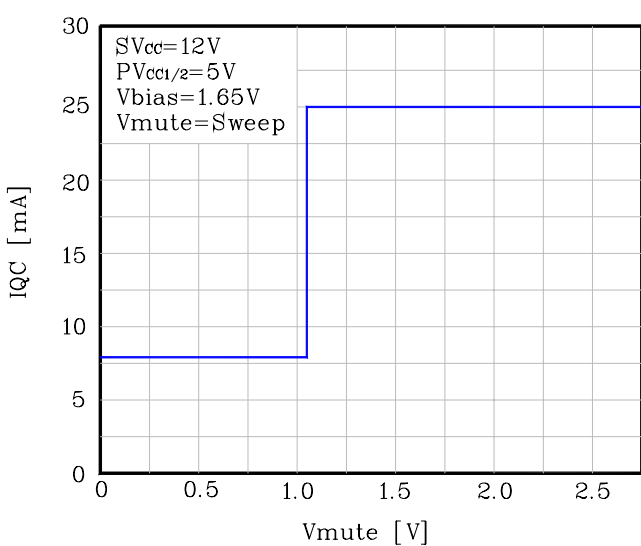

◆ Application Circuit

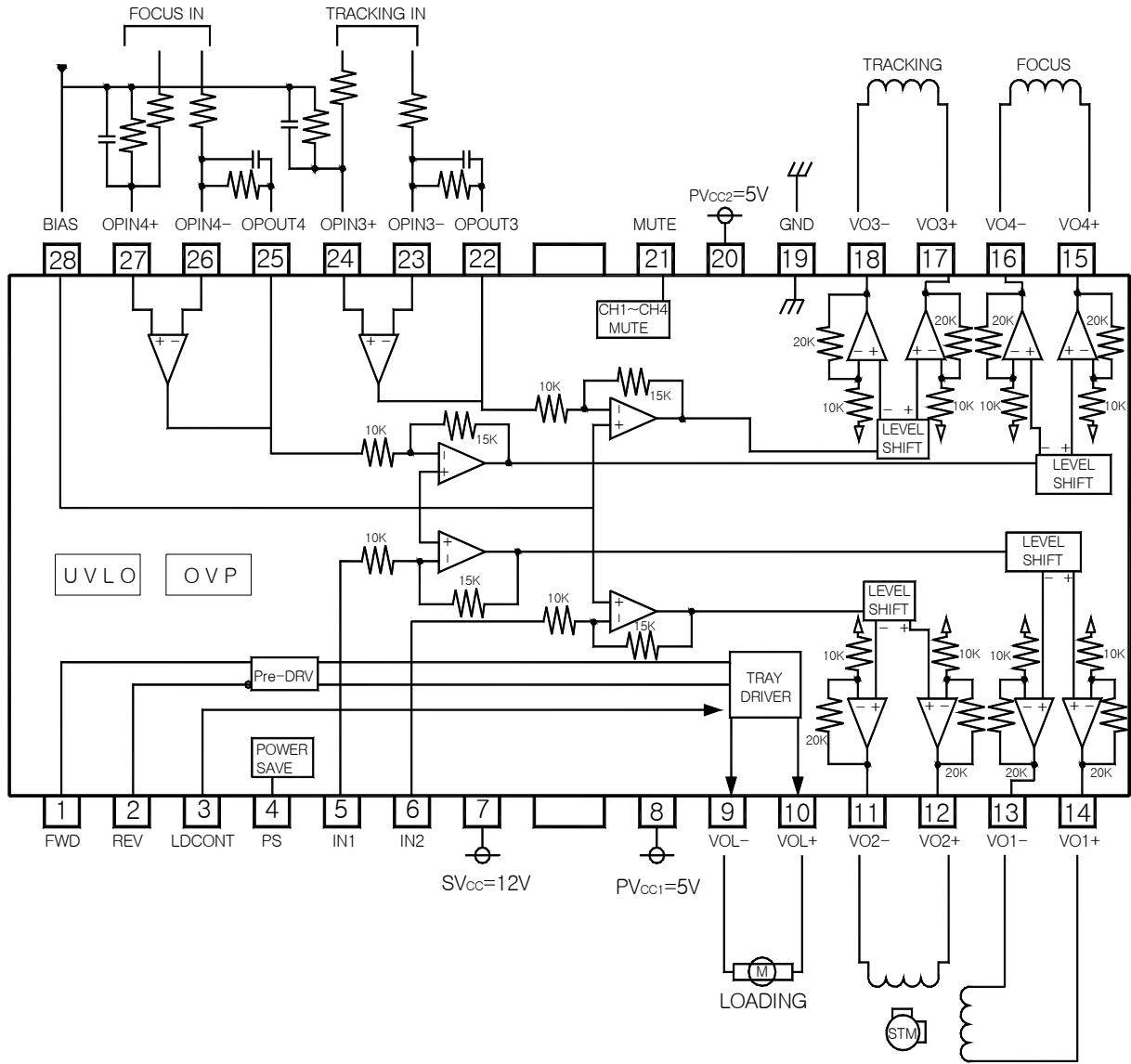

◆ Outline Dimension (Unit : mm)

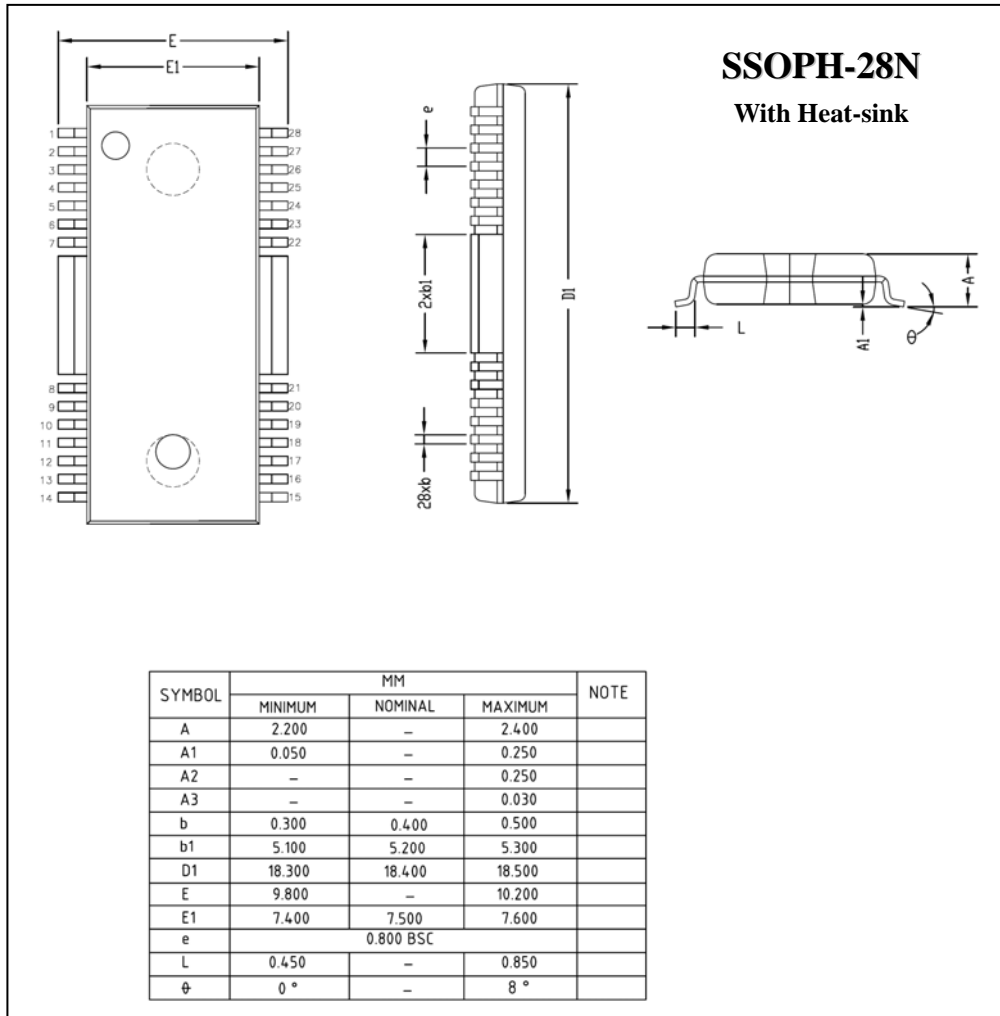

※ Recommend PCB solder land (Unit : mm)

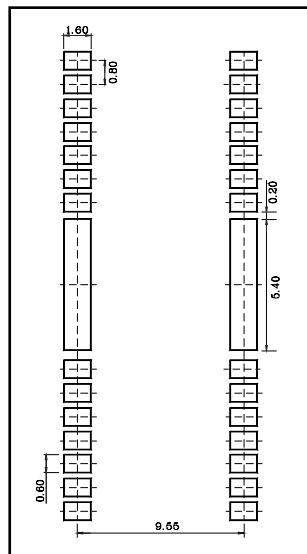

**The AUK Corp. products are intended for the use as components in general electronic equipment (Office and communication equipment, measuring equipment, home appliance, etc.).**

**Please make sure that you consult with us before you use these AUK Corp. products in equipments which require high quality and / or reliability, and in equipments which could have major impact to the welfare of human life(atomic energy control, airplane, spaceship, transportation, combustion control, all types of safety device, etc.). AUK Corp. cannot accept liability to any damage which may occur in case these AUK Corp. products were used in the mentioned equipments without prior consultation with AUK Corp..**

**Specifications mentioned in this publication are subject to change without notice.**