

**SSOPH-28N**

With Heat-sink

## ORDERING INFORMATION

Product	Marking	Package
S3052	S3052	SSOPH-28N

### ▲ Marking Detail Information



- ① Device Code
- ② Year & Week Code

## Description

The S3052 is 5 Channel BTL DC motor driver IC for controlling the motors and actuators of DVD-Player and it contain 2 independent precision voltage regulators with adjustable range from 1.24V to 4V.

Furthermore, it offer a free comparator for spindle motor back emf detection. It supports various applications with pb free package.

## Application

- ◆ CD-Player
- ◆ CD-ROM
- ◆ DVD-Player

## Features and Benefits

- ◆ 1 Channel is bi-directional DC motor driver for tray.
- ◆ 4 Channels are voltage-type BTL drivers for actuators, sled and spindle motors.
- ◆ Built in Level shift circuit.
- ◆ Built in Thermal shut down circuit.
- ◆ Built in Mute mode.
- ◆ Built in 2 Regulator controllers.  
Adjustable range [ 1.25V to 4V ]
- ◆ A Free comparator  
Spindle motor back emf detection
- ◆ **Dual Actuator drivers**  
A general purpose input OP Provides differential input for signal addition.  
The output structure is two power OPAMPS in bridge configuration.
- ◆ **Sled motor driver**  
A general purpose input OP provides differential input for signal addition.  
The output structure is one power OPAMP in bridge configuration.
- ◆ **Spindle driver**  
Single input linear BTL driver. The output structure are two power OPAMPS in bridge configuration.
- ◆ **Tray Bi-directional driver**  
The DC motor driver supports forward/reverse control for tray motor.

◆ Internal Block Diagram & Pin Assignment

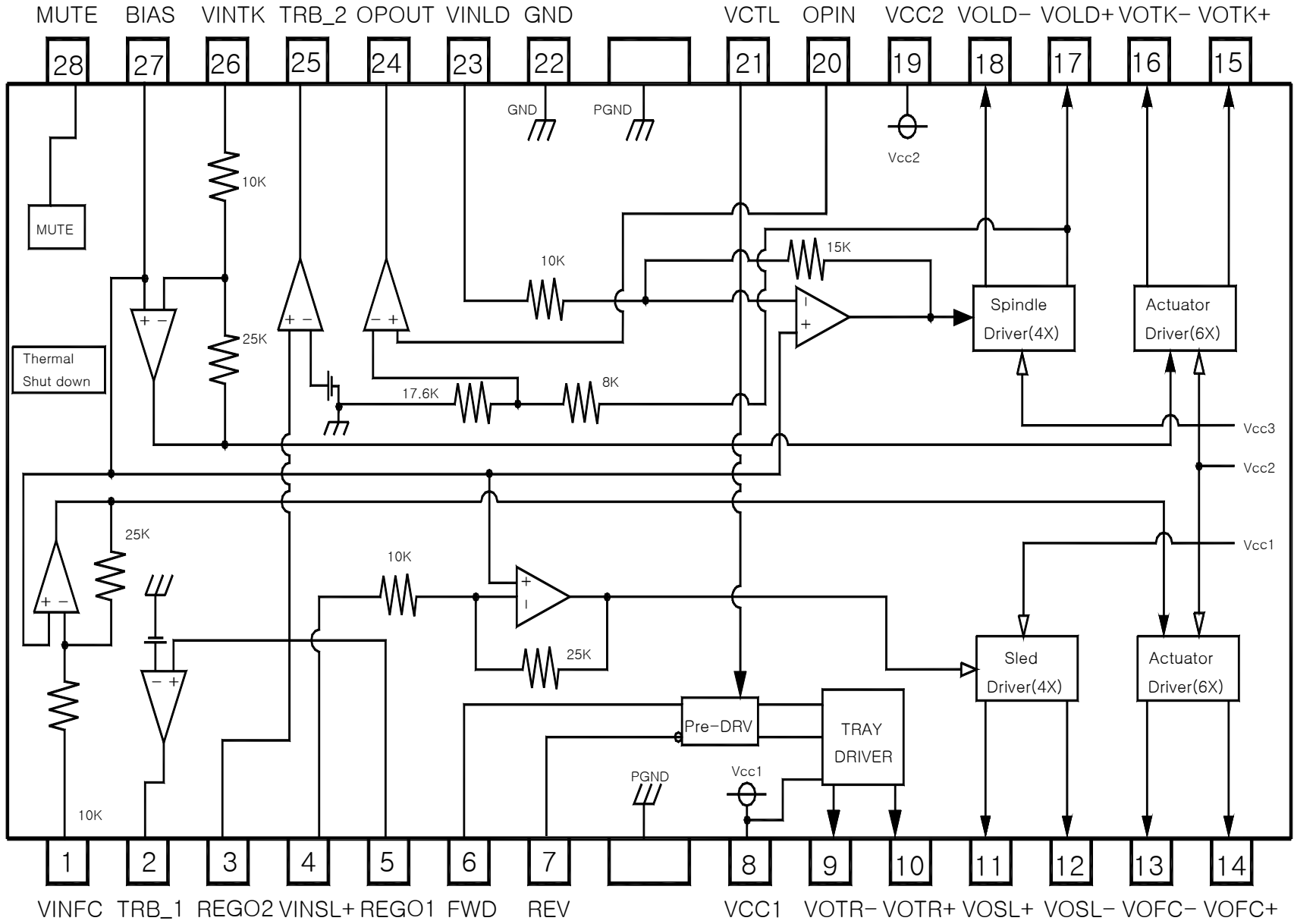

◆ Pin Description

NO	SYMBOL	I/O	DESCRIPTION
1	VINFC	I	Input for focus driver
2	TRB_1	O	Connect to external transistor base
3	REG02	I	Regulator voltage feedback, Connect to external bias resistor.
4	VINSL	I	Input for sled driver
5	REG01	I	Regulator voltage feedback, Connect to external bias resistor.
6	FWD	I	Tray driver input signal for forward direction
7	REV	I	Tray driver input signal for reverse direction
8	V <sub>CC1</sub>	PWR	V <sub>CC</sub> for pre-drive block and power block of sled & tray
9	VOTR-	O	Tray driver output (-)
10	VOTR+	O	Tray driver output (+)
11	VOSL+	O	Sled driver output (+)
12	VOSL-	O	Sled driver output (-)
13	VOFC-	O	Focus driver output (-)
14	VOFC+	O	Focus driver output (+)
15	VOTK+	O	Tracking driver output (+)
16	VOTK-	O	Tracking driver output (-)
17	VOLD+	O	Spindle driver output (+)
18	VOLD-	O	Spindle driver output (-)
19	V <sub>CC2</sub>	PWR	V <sub>CC</sub> for power block of focus, tracking and spindle
20	OPIN	I	Comparator input
21	VCTL	I	Speed control input of tray driver
22	GND	-	Ground
23	VINLD	I	Input for spindle driver
24	OPOUT	O	Comparator output
25	TRB_2	O	Connect to external transistor base
26	VINTK	I	Input for tracking driver
27	BIAS	I	Input for reference voltage
28	MUTE	I	Input for mute control

Symbol of + and – [ output of drives ] means polarity to input pin.

For example : if voltage level of pin1 is high, pin14 is high

◆ Absolute Maximum Ratings (  $T_a = 25^\circ\text{C}$  )

Parameter	Symbol	Limits	Unit
Supply Voltage	$V_{CC1}/V_{CC2}$	13.5	V
Power Dissipation	$P_d$	1.7	W
Operate Temperature Range	$T_{opr}$	-35 ~ +85	$^\circ\text{C}$
Storage Temperature Range	$T_{stg}$	-55 ~ +150	$^\circ\text{C}$

[  $P_d$  ] When mounted on a 70mm×70mm×1.6mm glass epoxy board.

Reduced by 13.6mW for each increase in  $T_a$  of  $1^\circ\text{C}$

[  $T_{stg}$  ] Should not exceed  $P_d$  or SOA and  $T_j=150^\circ\text{C}$  values

◆ Guaranteed Operating Conditions (  $T_a = 25^\circ\text{C}$  )

Parameter	Symbol	Limits	Unit
Power Supply Voltage	$V_{CC1}$	4.3 ~ 13.2	V
	$V_{CC2}$	4.3 ~ $V_{CC1}$	V

◆ Power Dissipation Curve [  $P_d$  ]

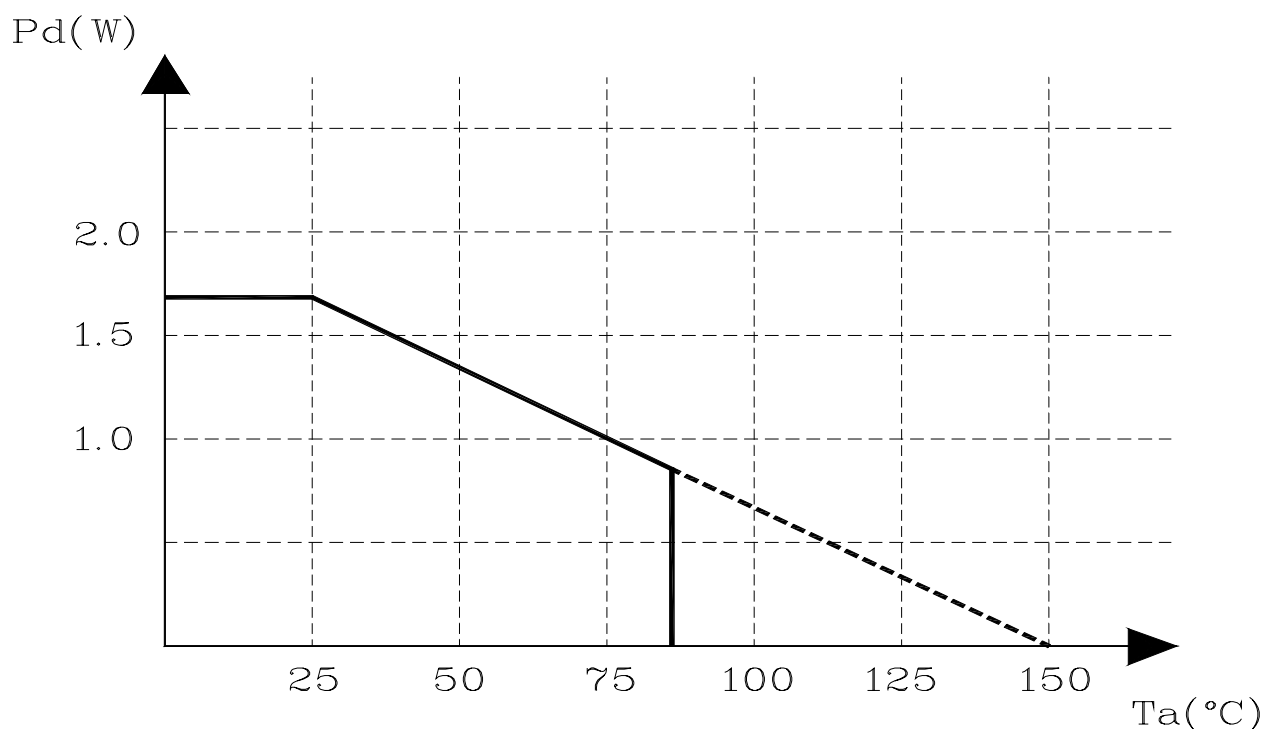

◆ 70mm×70mm×1.6mm glass epoxy board .

◆ De-rating is done at 13.6mW/ $^\circ\text{C}$  for operating above  $T_a=25^\circ\text{C}$

## ◆ Electrical characteristics

( Unless otherwise specified Ta=25 °C, Vcc1=12V, Vcc2=5V, BIAS=2.5V, RL=8Ω/12Ω/20Ω/45Ω)

NO	Characteristics	Symbol	Condition	Specification			Unit
				MIN.	TYP.	MAX.	
1	Quiescent current	Iqc		-	30	-	mA
2	Voltage for Mute on	Vston		0	-	0.5	V
3	Voltage for Mute off	Vstoffs		2	-	5	V
<b>&lt; Actuator Driver: Focus, Tracking &gt;</b>							
4	Output Offset Voltage	Voo		-50	-	50	mV
5	Maximum output Voltage	Vom	@12Ω Load	3.6	4	-	V
6	Voltage Gain	Gv	VIN=BIAS+0.2Vpp ac @1khz	21.5	23.5	25.5	dB
<b>&lt; Sled Motor Driver &gt;</b>							
7	Output Offset Voltage	Voosl		-100	-	100	mV
8	Maximum output Voltage	Vomsl	@20Ω Load	7.5	9.0	-	V
9	Voltage Gain	Gvsl	VIN=BIAS+0.2Vpp ac @1khz	18.0	20.0	22.0	dB
<b>&lt; Spindle Motor driver &gt;</b>							
10	Output Offset Voltage	Voold		-50	-	50	mV
11	Maximum output Voltage	Vomld	@8Ω Load	-	3.5	-	V
12	Voltage Gain	Gvld	VIN=BIAS+0.2Vpp ac @1khz	13.5	15.5	17.5	dB
<b>&lt; Tray Motor driver &gt;</b>							
13	Output saturation Voltage1	Vsat1	Upper + Lower saturation IL=200mA	0.7	1.1	1.5	V
14	Output saturation voltage between F&R	△Vsat1	Output saturation voltage1 between FWD and REV	-	-	0.1	V
15	Output saturation Voltage2	Vsat2	Upper + Lower saturation IL=500mA	1	1.55	2.2	V
16	Output adjustable gain on "H" side voltage	VvtrH	VCTL=2V	7.4	9.2	11	dB
<b>&lt; Tray Motor driver input logic &gt;</b>							
17	High level input voltage	VIH		1.5	-	Vcc	V
18	Low level input voltage	VIL		-0.3	-	0.5	V
19	High level input current	IIH	VFWD=VREV=5V	-	180.0	270.0	uA
<b>&lt; Regulator &gt;</b>							
20	Output voltage	Vreg	IL=500mA	2.35	2.5	2.65	V
				3.1	3.3	3.5	
21	Load Regulation	Vld	IL=0~500mA	-50.0	0.0	50.0	mV
22	Line Regulation	Vle	Vcc=4.5~8V, IL=500mA	-25.0	0.0	25.0	mV
<b>&lt; Comparator &gt;</b>							
23	High level output voltage	VOH	Vcc1=VRC=5V VOLD+=3V, OPIN=3V	-	-	Vcc	mV
24	Low level output voltage	VOL	Vcc1=VRC=5V VOLD+=3V, OPIN=1V	-	-	0.5	V
25	Output Sink Current	Isink1	Vcc1=VRC=5V, VOLD+=3V, OPIN=1V, RL=4.7k	0.80	1.0	-	mA
		Isink2	Vcc1=VRC=5V, VOLD+=3V, OPIN=1V	25.00	35.0	-	mA

[Regulator] It is based on STA353 PNP application. Vreg can be set to other voltage with 5% deviation.

## Application Information

### 1. Thermal Shut Down Circuit

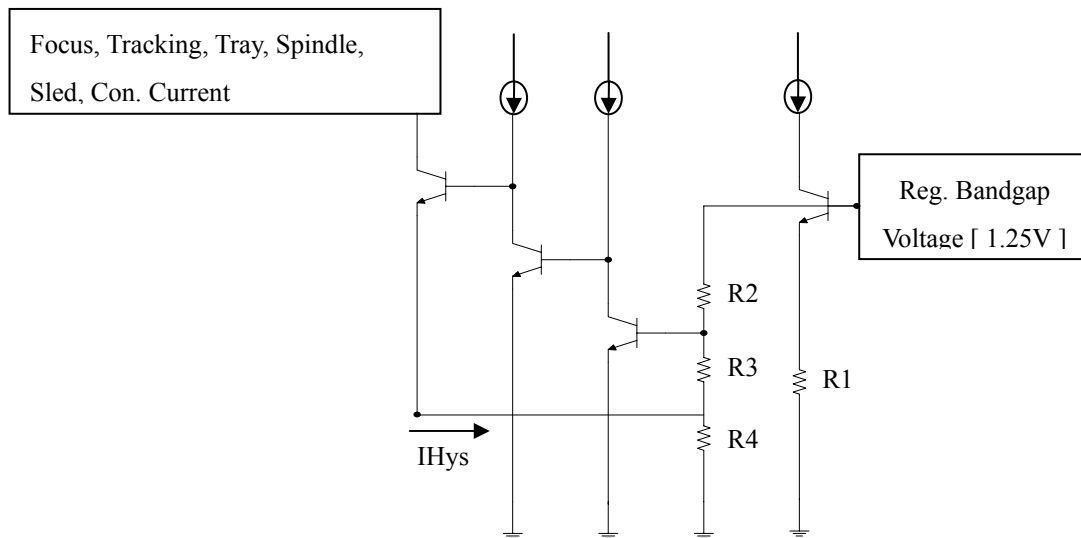

The built-in thermal shutdown circuit mutes the output current when the chip temperature reaches 175°C (typ.). The hysteresis is set to 25°C (typ.) by IHys, so the circuit will start up again when the chip temperature falling to 150°C (typ.)

### 2. Regulator Circuit

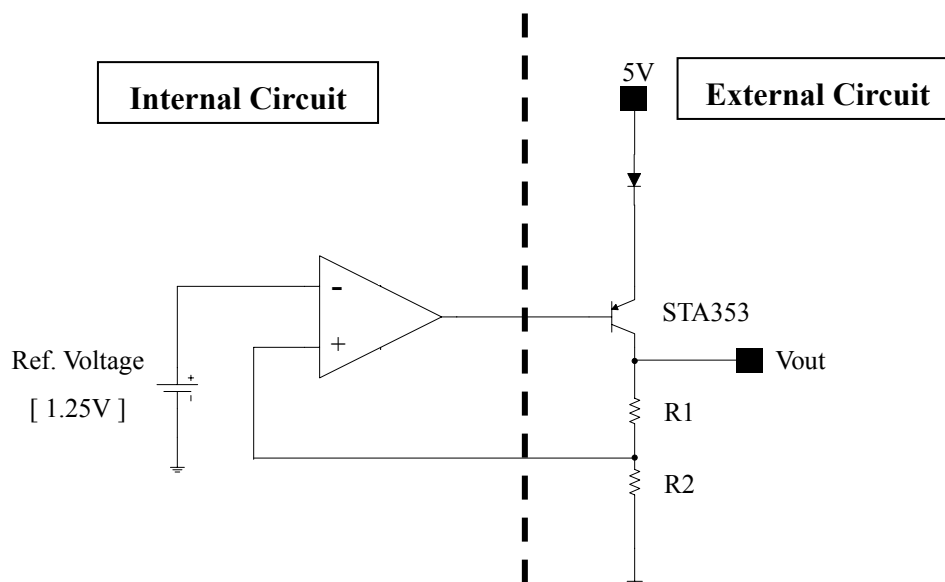

- The Ref. Voltage is generated by the internal circuit [Band gap reference]
- It needs to attach an external power TR [\* AUK PNP Power TR : STA353 \*]
- The output voltage of the regulator is calculated depend on R1 and R2's values.

$$V_{out} = (1 + R1/R2) \times 1.25$$

$$3.3V [R1: 16.5K / R2 : 10K]$$

$$2.5V [R1: 10K / R2 : 10K]$$

### 3. Bias & Mute Circuit

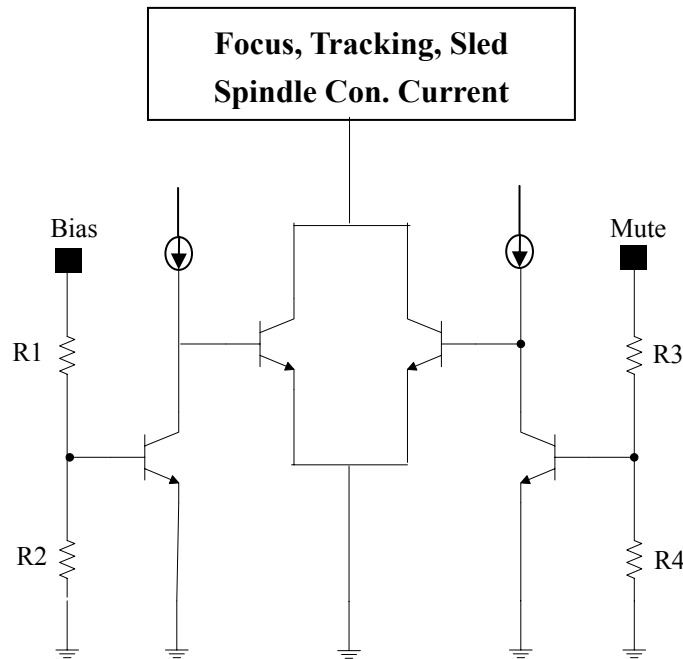

Bias pin (pin 27) should be pulled up to more than 1.2V. In case the bias pin's voltage is pulled down below 1.2V (typ.), the output current is muted, also Mute pin is same as Bias pin.  
 [Except Tray, Regulator, Comparator, those are only controlled by Vcc1. ]

### 4. Comparator Circuit

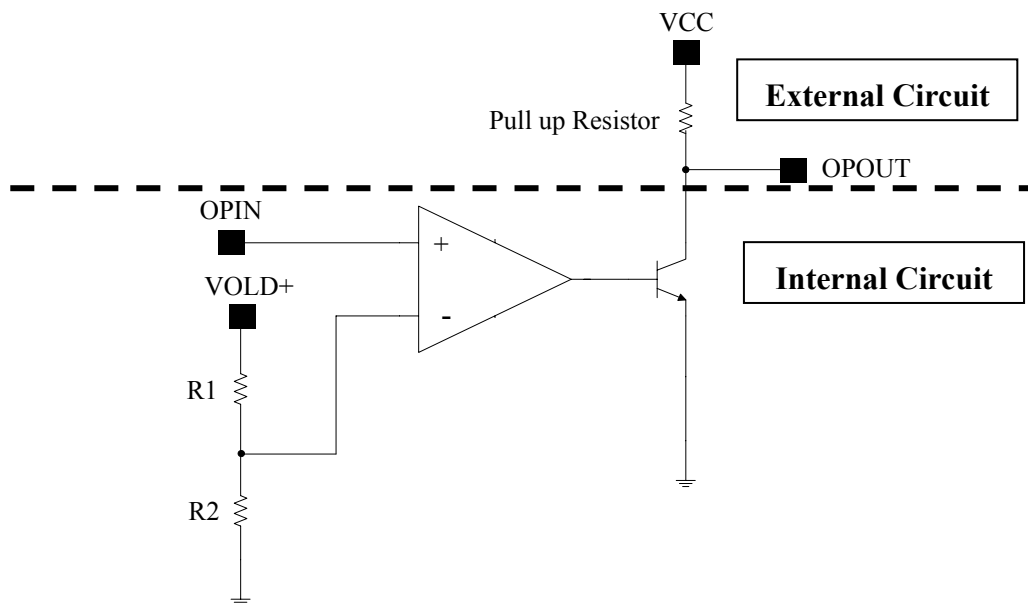

The Comparator is construction of open collector with external pulled up Resister for observation status of spindle motor.

## 5. BTL Driver Circuits [Focus, Tracking, Sled, Spindle]

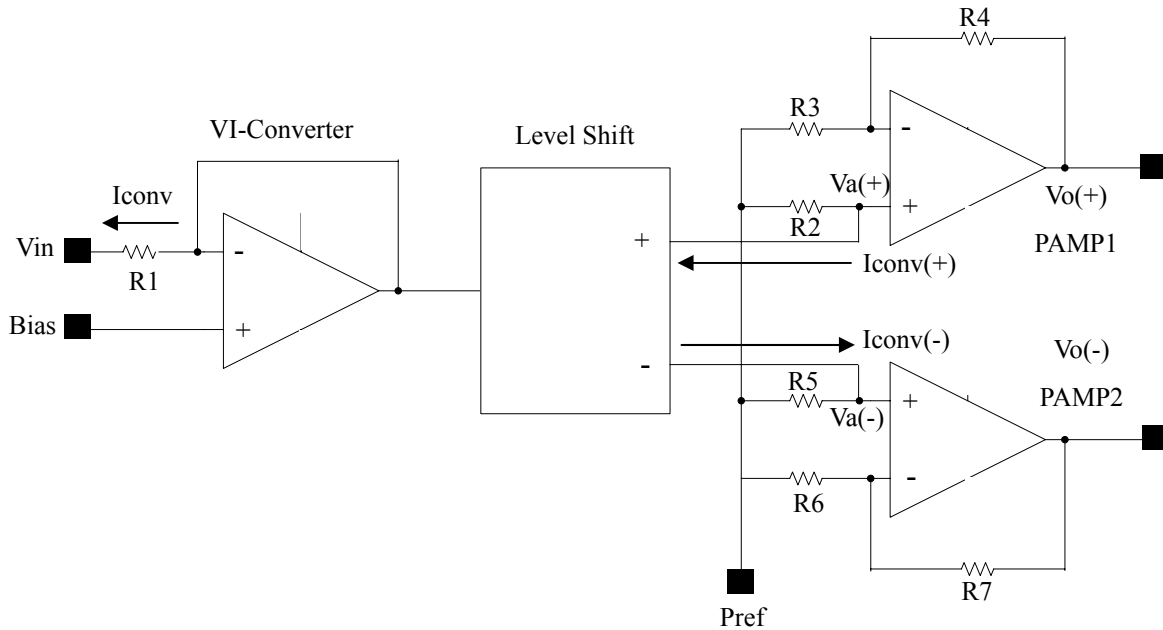

BTL Driver Circuits are composed of VI-Converter, Level Shifter and Output power AMP.

VI-Converter converts voltage of  $V_{in}$  into current [Iconv]

$$I_{conv} = (V_{in} - \text{Bias}) / R1 [10K\Omega]$$

### [ Closed loop Voltage Gain Calculation ]

$$V_{a(+)} = (R2 \times I_{conv}) + \text{Pref}$$

$$V_{a(-)} = (-R5 \times I_{conv}) + \text{Pref}$$

$$V_{o(+)} = V_{a(+)} \times (1 + R4/R3)$$

$$V_{o(-)} = V_{a(-)} \times (1 + R7/R6)$$

$$[* R2 = R5, R3 = R6, R4 = R7 *]$$

### Focus, Tracking closed loop Voltage Gain [ $R2 = 25K\Omega$ , $R3 = 10K\Omega$ , $R4 = 20K\Omega$ ]

$$\text{Gain} = 20 \log \left[ \frac{V_{o(+)} - V_{o(-)}}{V_{in} - \text{Bias}} \right]$$

$$= 20 \log \left[ \frac{V_{a(+)} \times (1 + R3/R4) - V_{a(-)} \times (1 + R6/R7)}{V_{in} - \text{Bias}} \right]$$

$$= 20 \log \left[ \frac{\{(R2 \times I_{conv}) + \text{Pref}\} \times (1 + R4/R3) - \{(-R5 \times I_{conv}) + \text{Pref}\} \times (1 + R7/R6)}{V_{in} - \text{Bias}} \right]$$

$$= 20 \log [2 \times (25K/10K) \times \{1 + (20K/10K)\}]$$

$$= 23.5 \text{ [dB]}$$

### Sled closed loop Voltage Gain [ $R2 = 25K\Omega$ , $R3 = 10K\Omega$ , $R4 = 10K\Omega$ ]

$$\text{Gain} = 20 \log [2 \times (25K/10K) \times \{1 + (10K/10K)\}]$$

$$= 20 \text{ [dB]}$$

### Spindle closed loop Voltage Gain [ $R2 = 15K\Omega$ , $R3 = 10K\Omega$ , $R4 = 10K\Omega$ ]

$$\text{Gain} = 20 \log [2 \times (25K/10K) \times \{1 + (10K/10K)\}]$$

$$= 15.5 \text{ [dB]}$$

6] Tray driver logic input

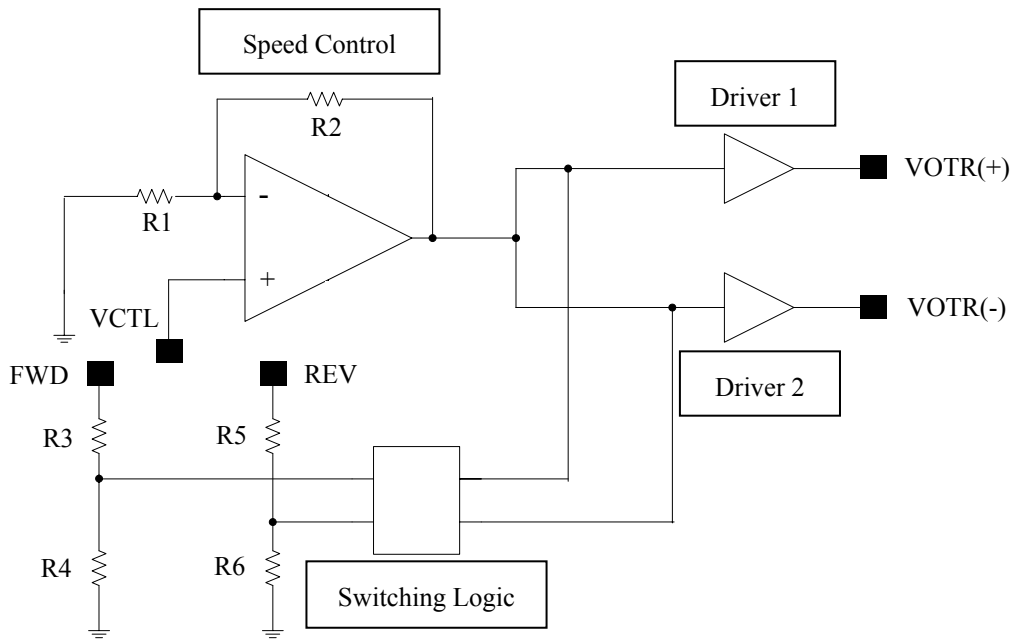

FWD [pin6]	REV [pin7]	VOTR+ [pin10]	VOTR- [pin9]	FUNCTION
L	L	OPEN	OPEN	Open mode
L	H	L	H	Reverse mode
H	L	H	L	Forward mode
H	H	L	L	Brake mode

Input circuit of pin6 [FWD] and pin7 [REV] is designed to avoid simultaneous activation of upper and lower output power TR. however, in order to improve reliability, apply motor forward/reverse input once through open mode. We recommend that the time period of open state is longer than 10msec.

“H” side output voltage on output voltage [VOL+, VOL-] varies depending on output control terminal for tray. [pin21]“H” side output voltage is set three times (9.2dB typ.) VTCL [pin21], and “L” side output voltage is equal to output saturation voltage.

### Characteristic Diagrams

Fig. 1  $V_{CC} - I_{QC}$

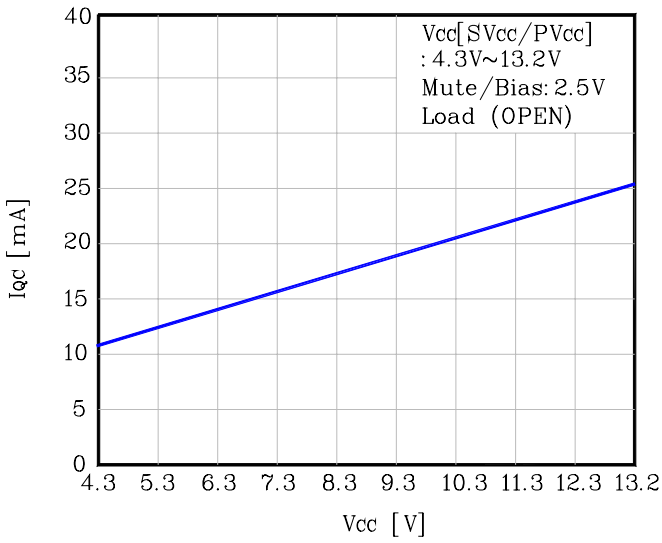

Fig. 2 Temperature -  $I_{QC}$

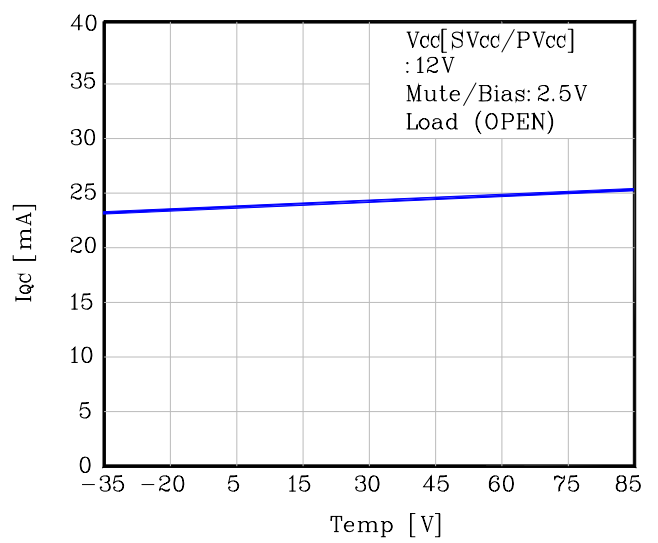

Fig. 3  $V_{OM} - V_{CC}$

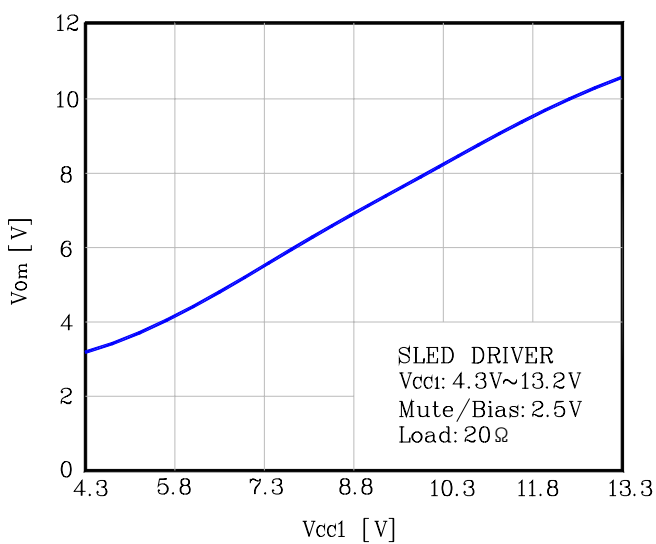

Fig.4  $V_{OM} - V_{CC}$

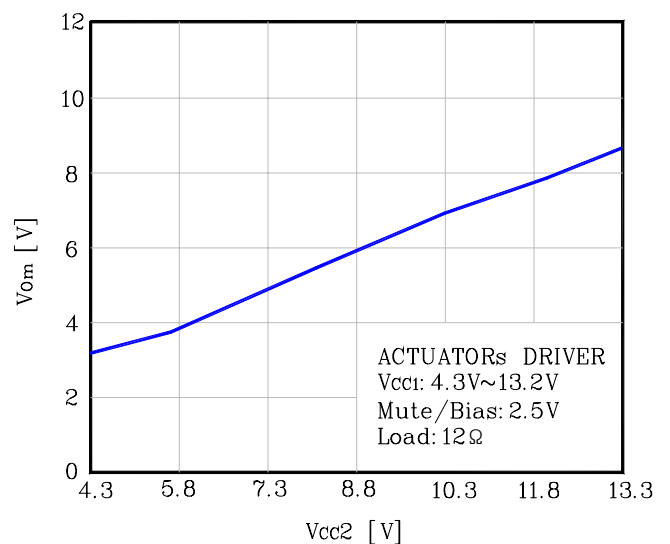

Fig. 5  $V_{OM} - V_{CC}$

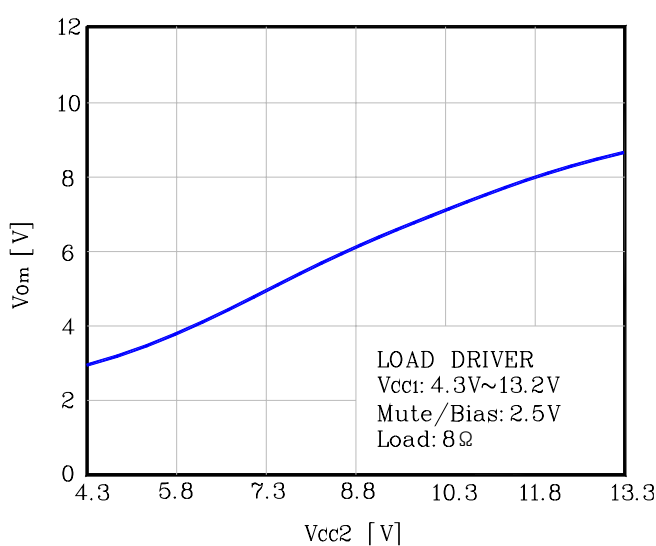
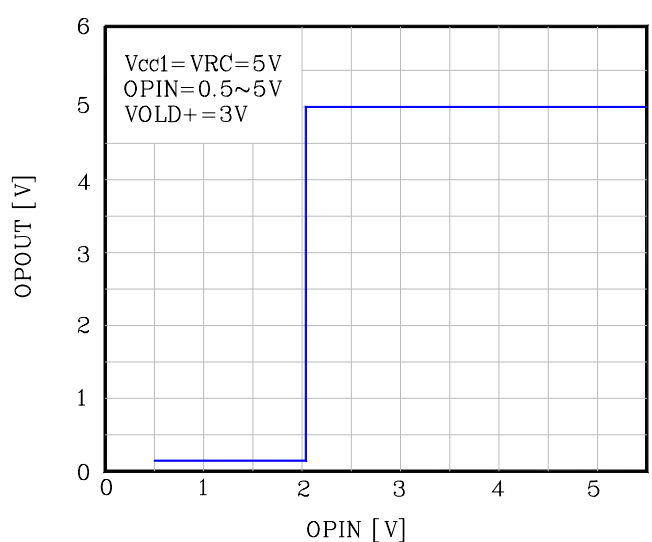

Fig.6 OP  $V_{IN} - OP V_O$







◆ Outline Dimension

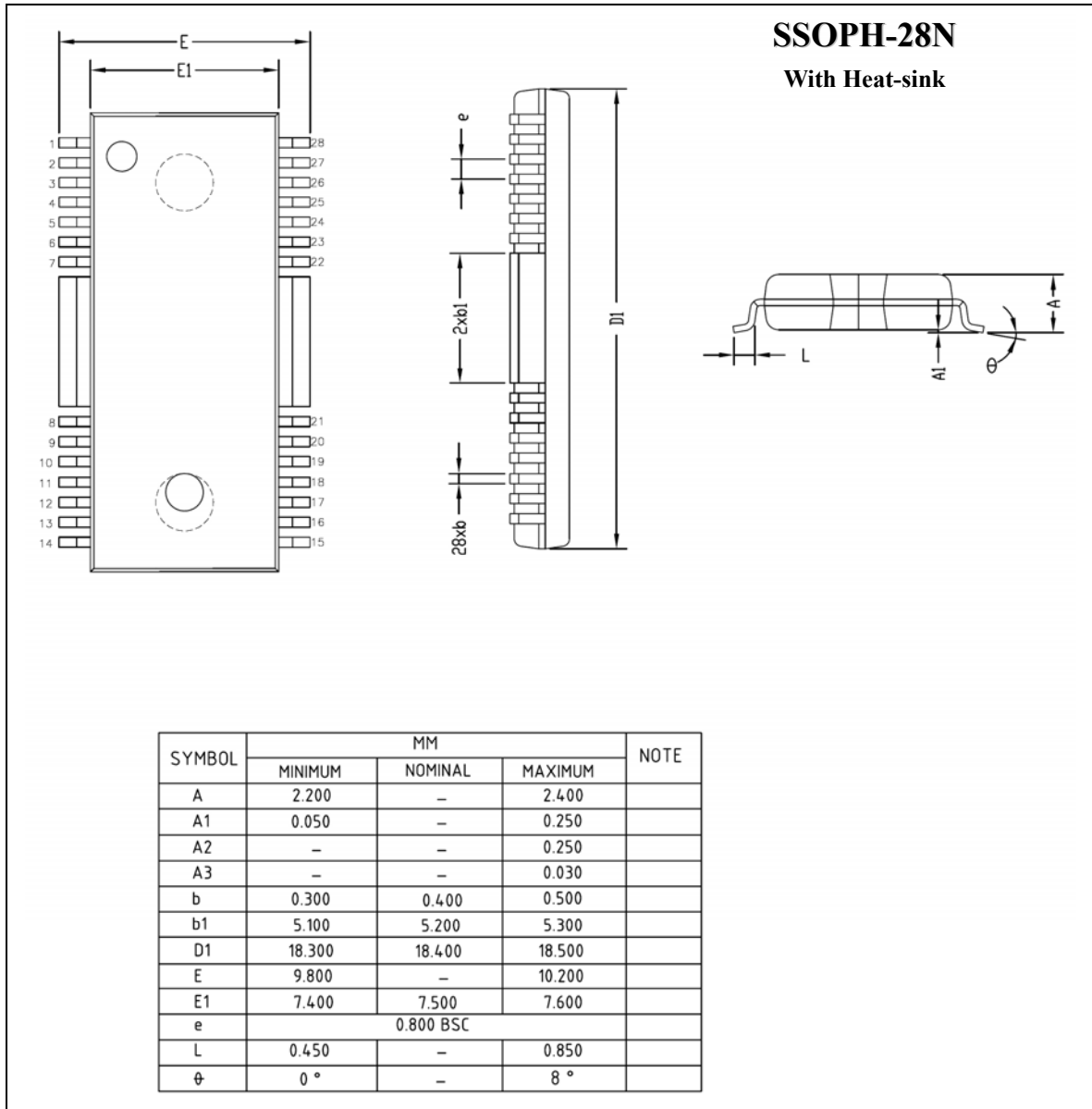

**The AUK Corp. products are intended for the use as components in general electronic equipment (Office and communication equipment, measuring equipment, home appliance, etc.).**

**Please make sure that you consult with us before you use these AUK Corp. products in equipments which require high quality and / or reliability, and in equipments which could have major impact to the welfare of human life(atomic energy control, airplane, spaceship, transportation, combustion control, all types of safety device, etc.). AUK Corp. cannot accept liability to any damage which may occur in case these AUK Corp. products were used in the mentioned equipments without prior consultation with AUK Corp..**

**Specifications mentioned in this publication are subject to change without notice.**