

**1. Material** Substrate GaAlAs (N Type) Removed  
Epitaxial Layer GaAlAs (P/N Type)

**2. Electrode** N(Cathode) Side Gold Alloy  
P(Anode) Side Gold Alloy

**3. Electro-Optical Characteristics**

Parameter	Symbol	Min	Typ	Max	Unit	Condition
Forward Voltage	$V_{F(1)}$		1.1		V	IF=10uA
	$V_{F(2)}$		1.5	1.7	V	IF=30mA
Reverse Voltage	$V_R$	4			V	IR=10uA
Power	$P_O$	11	12		mW	IF=30mA
Wavelength	$\lambda_P$		880		nm	IF=50mA
	$\Delta\lambda$		45		nm	IF=50mA
Rise Time	$T_r$		15		ns	
Fall Time	$T_f$		6.3		ns	

※ Note : Power is measured by Sorter E/T system with bare chip.

**4. Mechanical Data**

- (a) Emission Area ----- 10.8mil x 10.8mil
- (b) Bottom Area ----- 11.8mil x 11.8mil
- (c) Bonding Pad ----- 100um
- (d) Chip Thickness ----- 7mil
- (e) Junction Height ----- 6.3mil

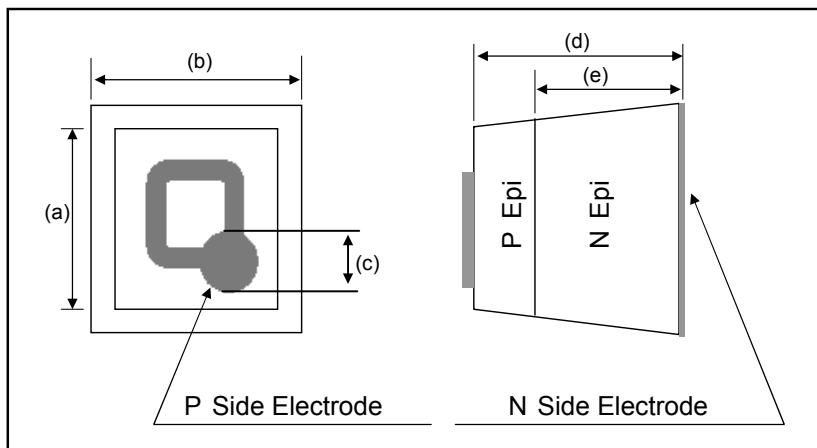

**AUK Corp.**

Eoyang factory, 513-5 Eoyang-dong, Iksan, 570-210, Korea

Tel. +82 63 839 1111 Fax. +82 63 835 8259

[www.auk.co.kr](http://www.auk.co.kr)

