

OPA6316

Orange LED Chip

GaAsP/GaP

1. Material Substrate GaP (N Type)
Epitaxial Layer GaAsP (P/N Type)

2. Electrode N(Cathode) Side Gold Alloy
P(Anode) Side Gold Alloy

3. Electro-Optical Characteristics

Parameter	Symbol	Min	Typ	Max	Unit	Condition
Forward Voltage	$V_{F(1)}$		1.6		V	IF=1mA
	$V_{F(2)}$			2.2	V	IF=20mA
Reverse Voltage	V_R	8			V	IR=10uA
Brightness	Iv	180	200		mcd	IF=20mA
Wavelength	λ_d		618		nm	IF=20mA
	$\Delta\lambda$		40		nm	IF=20mA

※ Note : Brightness is measured by Sorter E/T system with bare chip.

4. Mechanical Data

(a) Emission Area	-----	10mil x 10mil
(b) Bottom Area	-----	11mil x 11mil
(c) Bonding Pad	-----	115um
(d) Chip Thickness	-----	11mil
(e) Junction Height	-----	10.6mil

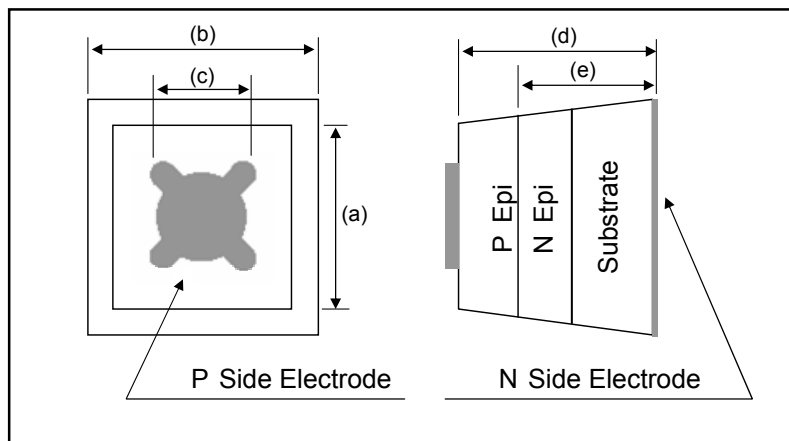

AUK Corp.

Eoyang factory, 513-5 Eoyang-dong, Iksan, 570-210, Kc

Tel. +82 63 839 1111 Fax. +82 63 835 8259

www.auk.co.kr

