

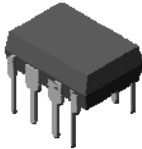

**SOP-8**

**DIP-8**
**ORDERING INFORMATION**

Product	Marking	Package
S6419	S6419	SOP-8
S6419P	S6419	DIP-8

**▲ Marking Information**

① Device Code

② YWW : Year &amp; Week Code

□ : Assembly Plant Code

**Description**

The S6419/P is a low power audio amplifier integrated circuit, intended for the communication applications, such as in speakerphones. It provides differential speaker outputs to maximize output swing at low supply voltages.

Coupling capacitor to the speaker is not required. Open loop gain is around 80dB, and the closed loop gain is set with two external resistors [ Rf and Ri : refer to page 2].

A chips disable pin permits powering down and/or muting the input signal.

**Application**

- ◆ Telephone
- ◆ Speakerphone
- ◆ Fax machine & Combination Printer

**Features and Benefits**

- ◆ Wide range of operating supply voltage (2~16V) for telephone line powered applications.
- ◆ Low quiescent supply current (typ.)2.0mA for battery powered applications.
- ◆ Added disable input for saving power  
Low muting mode supply current (Typ.)65uA.
- ◆ Available to drives a wide range of load ( 8Ω to 100Ω )
- ◆ Output power exceeds 250mW with 32Ω Speaker.
- ◆ Low total harmonic distortion (Typ.) 0.5%
- ◆ Few external components are required.

◆ Internal Block Diagram & Typical Application Circuit

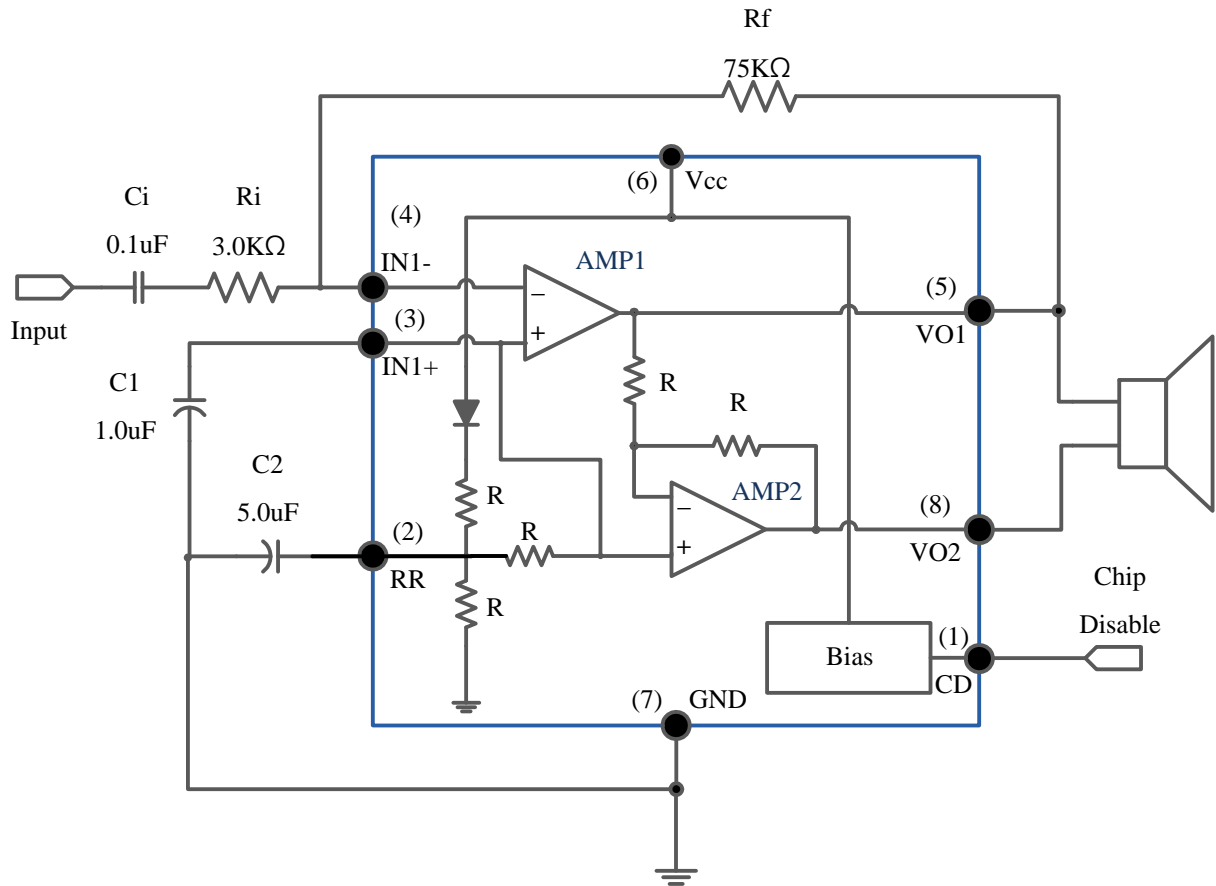

C2 : Optional external Cap.

Differential Gain :  $2 \cdot (R_f/R_i)$

◆ Pin Description

No	Symbol	I/O	Description
1	Chip Disable	I	This pin can be used to power down the IC to conserve power, or for muting. Enable(Open or less than 0.8V), Disable (2.0V to Vcc)
2	RR	I	A capacitor at this pin increase PSRR and affects turn-on time. This pin can be left open if the capacitor at pin 1 is sufficient.
3	IN1(+)	I	OP-Amp1's Non-inverting Input
4	IN1(-)	I	OP-Amp1's Inverting Input
5	VO1	O	Differential Output1 [ DC Level: $(V_{CC}-0.7V)/2$ ]
6	V <sub>CC</sub>	PWR	V <sub>CC</sub> for Audio Amplifier
7	GND	GND	GND
8	VO2	O	Differential Output2 [ DC Level : $(V_{CC}-0.7V)/2$ ]

**Absolute maximum ratings ( Ta=25°C)**

Characteristic	Symbol	Ratings	Unit	
Supply voltage	$V_{CC}$	-1 to +18	V	
Output current	$I_{OUT}$	$\pm 250$	mA	
Input voltage at RR, CD, IN(+), IN(-)	$V_{IN}$	-1 to $V_{CC}+1$	V	
Applied output voltage to VO1, VO2 (disable)	$V_O$	-1 to $V_{CC}+1$	V	
Power Dissipation	$P_D$	SOP-8	600	mW
		DIP-8	1000	mW
Operating temperature	$T_{opr}$	-20 ~ +70	°C	
Storage temperature	$T_{stg}$	-55 ~ 150	°C	

**Recommended Operation Conditions ( Ta=25°C)**

Characteristic	Symbol	Min.	Typ.	Max.	Unit
Supply voltage	$V_{CC}$	2.0	-	16.0	V
Load Impedance	$R_L$	8.0	-	100	$\Omega$
Peak Load Current	$I_L$	-	-	$\pm 200$	mA
Differential Gain (5.0KHz Bandwidth)	AVD	0	-	46	dB
Voltage at chip disable	VCD	0	-	$V_{CC}$	V
Ambient Temperature	$T_a$	-20	-	70	°C

## Electrical Characteristics

(Unless otherwise specified.  $V_{CC} = 6V$ ,  $T_a = +25\text{ }^\circ\text{C}$ )

Characteristic	Symbol	Test Condition	Min.	Typ.	Max.	Unit
Amplifiers ( DC Characteristics )						
Output DC Level @ VO1,VO2	VO(3V)	$V_{CC}=3.0V, R_L=16\Omega, R_f=75K\Omega$	1.0	1.15	1.25	V
	VO(6V)	$V_{CC}=6.0V, R_L=16\Omega, R_f=75K\Omega$	-	2.65	-	
	VO(12V)	$V_{CC}=12.0V, R_L=16\Omega, R_f=75K\Omega$	-	5.65	-	
Output High Level	$V_{OH}$	$2.0V \leq V_{CC} \leq 16V, I_{OUT} = -75mA$	-	$V_{CC-1.0}$	-	V
Output Low Level	$V_{OL}$	$2.0V \leq V_{CC} \leq 16V, I_{OUT} = 75mA$	-	0.16	-	V
Output DC Offset Voltage (VO1-VO2)	$\Delta VO$	$V_{CC}=6.0V, R_L=32\Omega, R_f=75K\Omega$	-30	0	+30	mV
Input Bias Current	$I_{IB}$	$V_{CC}=6.0V$	-	-100	-200	nA
Equivalent Resistance @ IN1+	$R_{EQ}$	$V_{CC}=6.0V$	100	150	220	K $\Omega$
Equivalent Resistance @ RR		$V_{CC}=6.0V$	18	25	40	K $\Omega$
Chip Disable ( Pin 1 )						
Input Voltage (Low)	$V_{IL}$	-	-	-	0.8	V
Input Voltage (High)	$V_{IH}$	-	2.0	-	-	V
Input Resistance	$R_{CD}$	$V_{CC}=V_{CD}=16V$	50	90	175	K $\Omega$
Power Supply						
Power Supply Current	$I_{CC(3V)}$	$V_{CC}=3.0V, R_L=\infty, CD=0.8V$	-	2.0	3.0	mA
	$I_{CC(16V)}$	$V_{CC}=16.0V, R_L=\infty, CD=0.8V$	-	3.0	4.0	mA
	$I_{CC(Disable)}$	$V_{CC}=3.0V, R_L=\infty, CD=2.0V$	-	65	100	$\mu\text{A}$
Amplifiers ( AC Characteristics )						
Open Loop Gain (AMP.1)	$G_{V1}$	-	80	-	-	dB
Open Loop Gain (AMP.2)	$G_{V2}$	$V_{CC}=3.0V, R_L=16\Omega, f=1.0KHz$	-0.35	0	+0.35	dB
Gain Bandwidth Product	GBW	-	-	1.5	-	MHZ
Output Power	$P_{OUT(3V)}$	$V_{CC}=3.0V, R_L=16\Omega, THD \leq 10\%$	55	-	-	mW
	$P_{OUT(6V)}$	$V_{CC}=6.0V, R_L=32\Omega, THD \leq 10\%$	250	-	-	
	$P_{OUT(12V)}$	$V_{CC}=12.0V, R_L=100\Omega, THD \leq 10\%$	400	-	-	
Total Harmonic Distortion (f=1.0KHz)	THD	$V_{CC}=6.0V, R_L=32\Omega, P_{OUT}=125mW$	-	0.5	1.0	%
		$V_{CC} \geq 3.0V, R_L=8\Omega, P_{OUT}=20mW$	-	0.5	-	
		$V_{CC} \geq 12V, R_L=32\Omega, P_{OUT}=200mW$	-	0.6	-	
Power Supply Rejection ( $V_{CC}=6.0V, \Delta V_{CC}=3.0V$ )	PSRR	**C1= $\infty$ , C2=0.01 $\mu\text{F}$	50	-	-	dB
		**C1=0.1 $\mu\text{F}$ , C2=0, f=1.0KHz	-	12	-	
		**C1=1.0 $\mu\text{F}$ , C2=5.0 $\mu\text{F}$ , f=1.0KHz	-	52	-	
Muting	$G_{V(mute)}$	Mute=2V, 1KHz < f < 20KHz	-	>70	-	dB

\*\* External Capacitance C1, C2 : Refer to the Page 2 (Typical application circuit.)

**Fig.1 Supply Current vs.  $V_{CC}$**

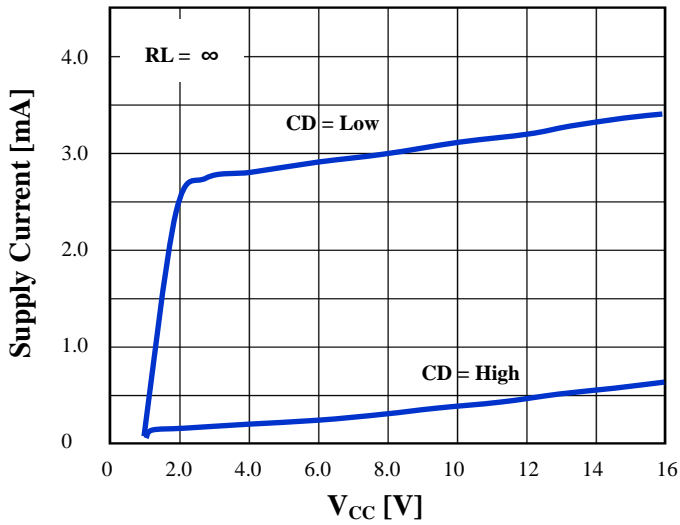

**Fig.2 Supply Current vs. Ambient Temp.**

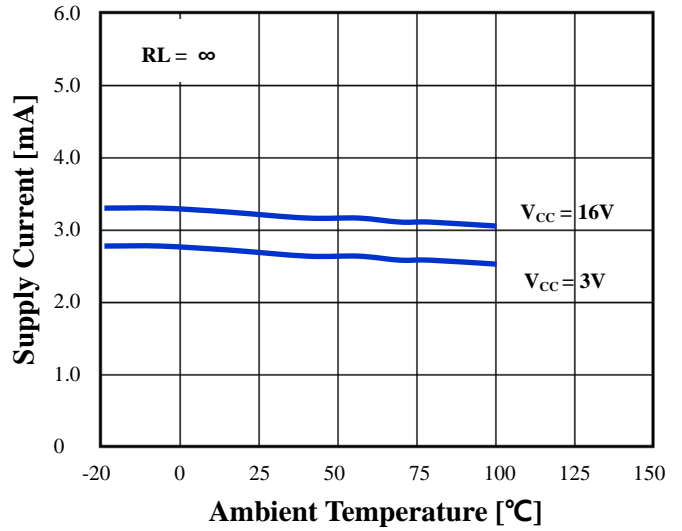

**Fig.3 Small Signal Response**

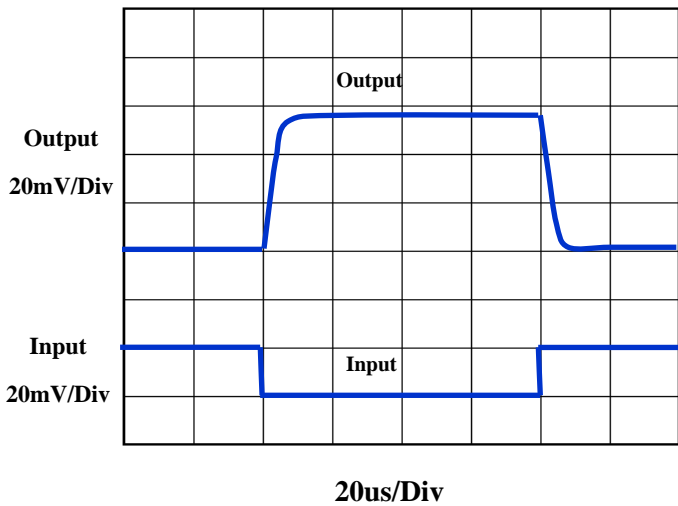

**Fig.4 Large Signal Response**

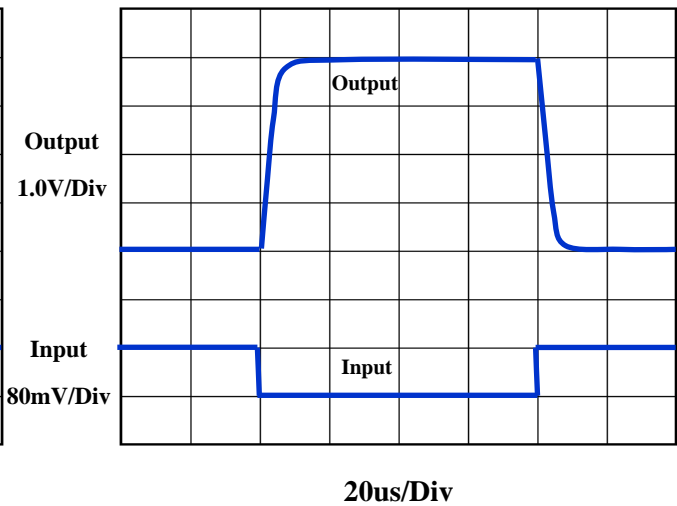

**Fig.5  $V_{CC}-V_{OH}$  vs. Load Current**

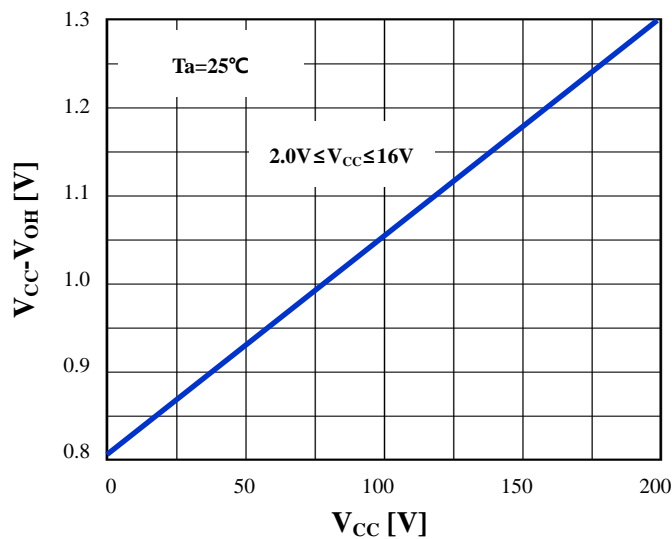

**Fig.6  $V_{OL}$  vs. Load Current**

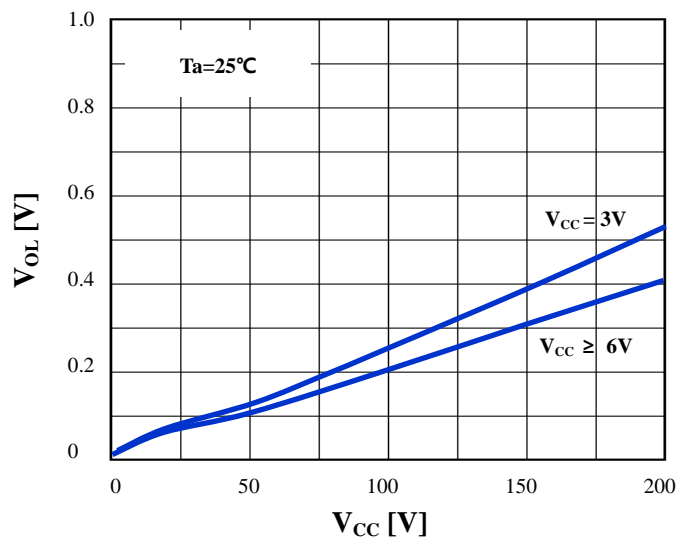

Fig.7 Device Dissipation [ 8.0Ω Load ]

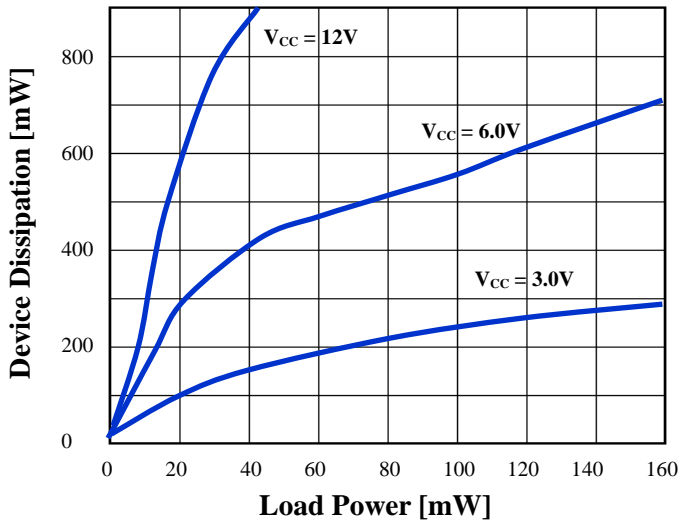

Fig.8 Device Dissipation [ 16Ω Load ]

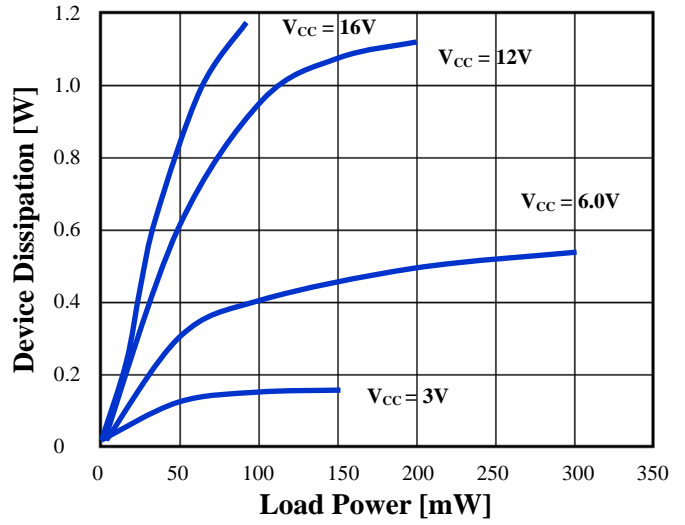

Fig.9 Device Dissipation [ 32Ω Load ]

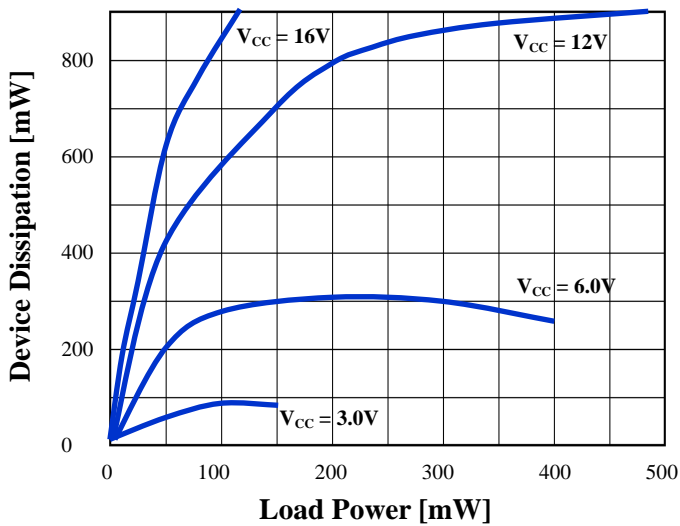

Fig.10 THD vs. Output Power

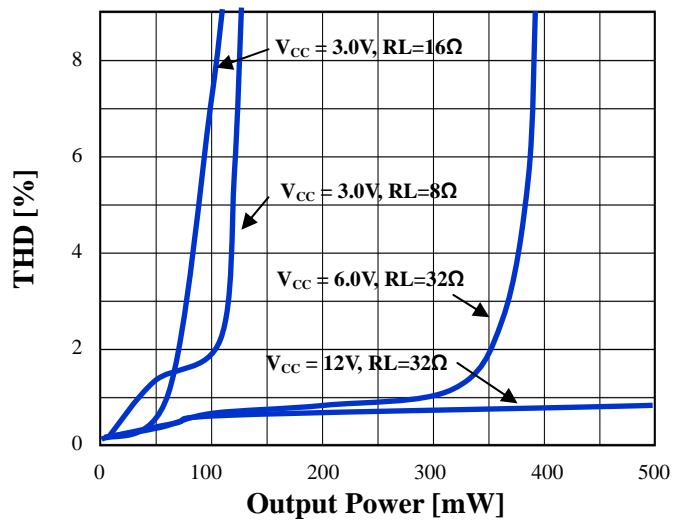

Fig.11 Differential Gain vs. Frequency

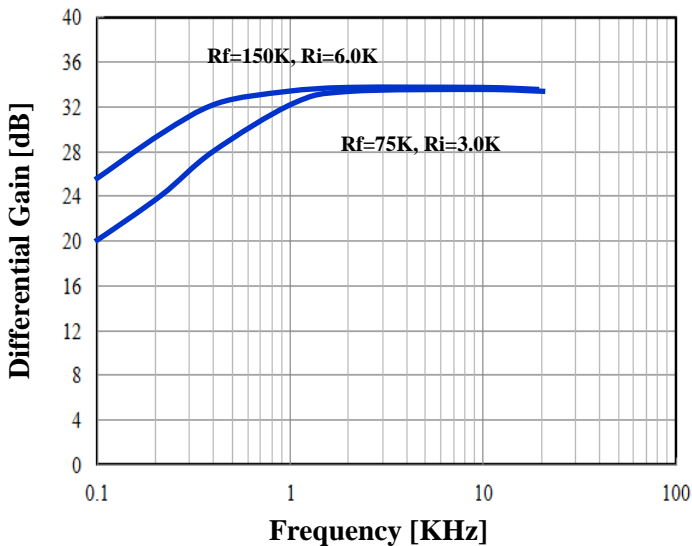
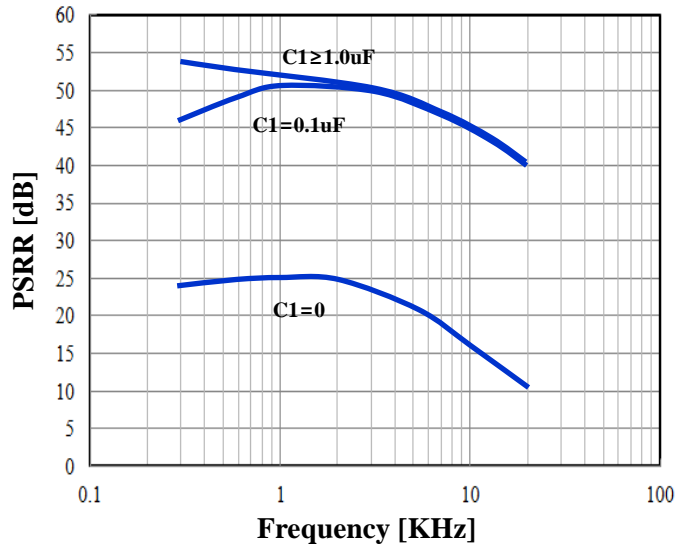
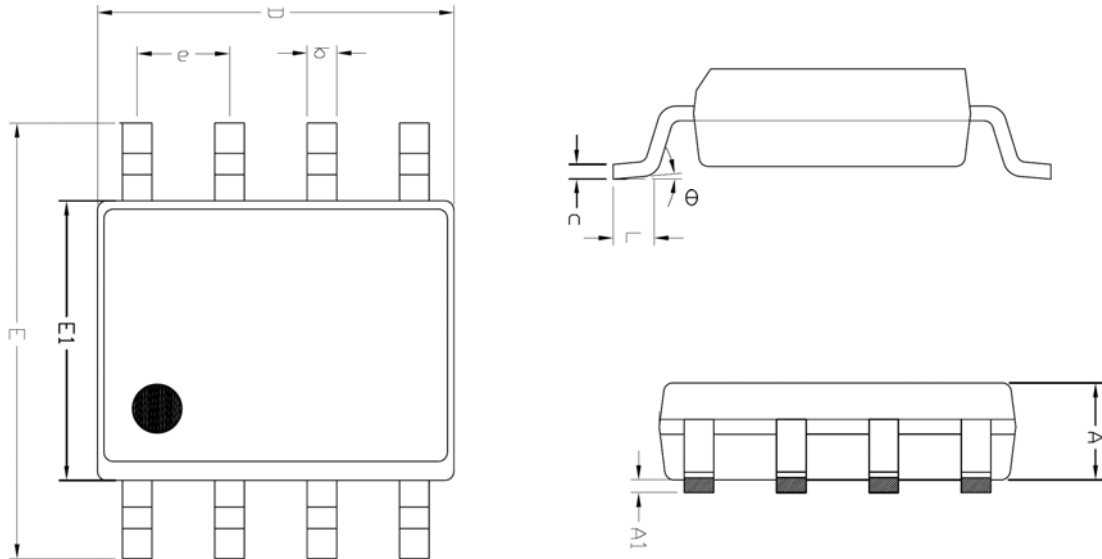

Fig.12 PSRR vs. Frequency @ C2=5.0uF



**Outline Dimension (Unit : mm)**



SYMBOL	MILLIMETER(mm)			NOTE
	MINIMUM	NOMINAL	MAXIMUM	
A	1.245	—	1.445	
A1	0.125	0.175	0.275	
b	0.320	0.420	0.520	
c	0.170	0.220	0.270	
D	4.802	4.902	5.002	
E	5.870	6.020	6.170	
E1	3.761	3.861	3.961	
e	1.270 BSC			
L	0.462	0.562	0.662	
θ	0 °	—	8 °	

**※ Recommend PCB solder land (Unit : mm)**

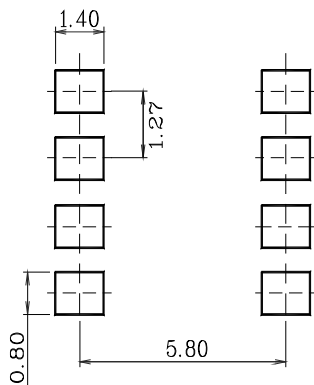

Outline Dimension (Unit : mm)

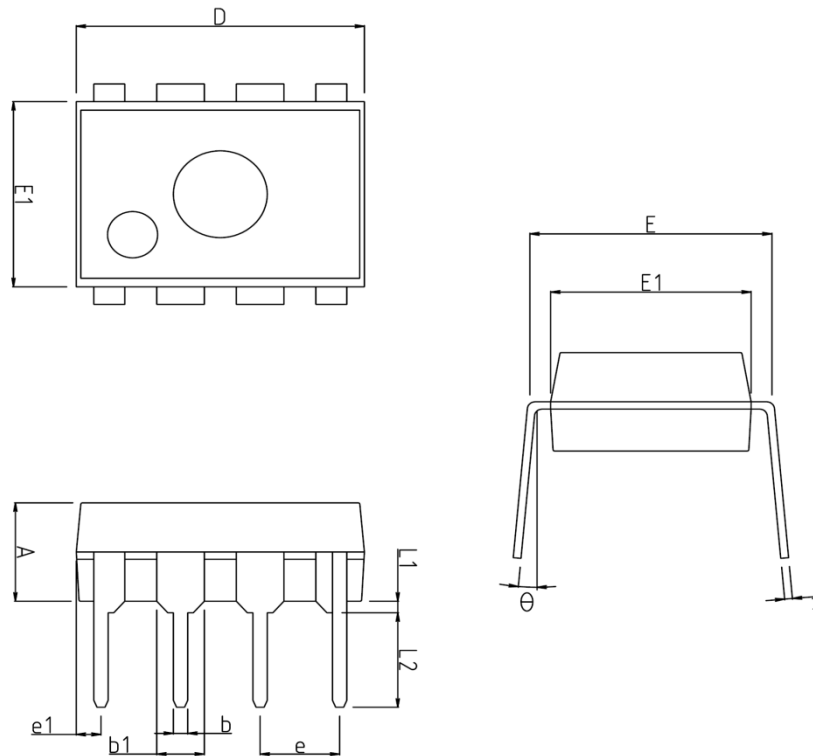

SYMBOL	MILLIMETERS			NOTE
	MINIMUM	NOMINAL	MAXIMUM	
A	3.20	3.40	3.60	
b	0.36	0.46	0.56	
b1	1.42	1.52	1.62	
c	0.20	0.25	0.35	
D	9.00	9.20	9.40	
E	7.37	7.62	7.87	
E1	6.20	6.40	6.60	
e	2.54 TYP			
e1	0.79 TYP			
L1	0.33	—	—	
L2	3.00	3.30	3.60	
$\theta$	0°	—	15°	

**The AUK Corp. products are intended for the use as components in general electronic equipment (Office and communication equipment, measuring equipment, home appliance, etc.).**

**Please make sure that you consult with us before you use these AUK Corp. products in equipments which require high quality and / or reliability, and in equipments which could have major impact to the welfare of human life(atomic energy control, airplane, spaceship, transportation, combustion control, all types of safety device, etc.). AUK Corp. cannot accept liability to any damage which may occur in case these AUK Corp. products were used in the mentioned equipments without prior consultation with AUK Corp..**

**Specifications mentioned in this publication are subject to change without notice.**