

1. Descriptions

The KP5630W5AD29 is a small and thin form plastic leaded chip carrier(PLCC) 4-pin package with InGaN blue Chip White LED.

2. Features

- ◆ Small Footprint Surface Mount Package (5.6 L × 3.0 W × 0.9 H [mm³])
- ◆ Typical Forward Voltage(V_F) : 3.1 V @ Forward Current(I_F)=60mA
- ◆ Operation Temperature from -40℃ to +85℃
- ◆ Soldering methods : IR reflow soldering
- ◆ Taping : 8mm conductive black carrier tape & antistatic clear cover tape

3. Applications

- ◆ Interior lighting
- ◆ General lighting
- ◆ Indoor and out door displays
- ◆ Architectural / Decorative lighting

The contents of this data sheet are subject to change without advance notice for the purpose of improvement.
When using this product, would you please refer to the latest specifications.

4. Outline Dimensions and Material Descriptions

◆ Outline Dimensions

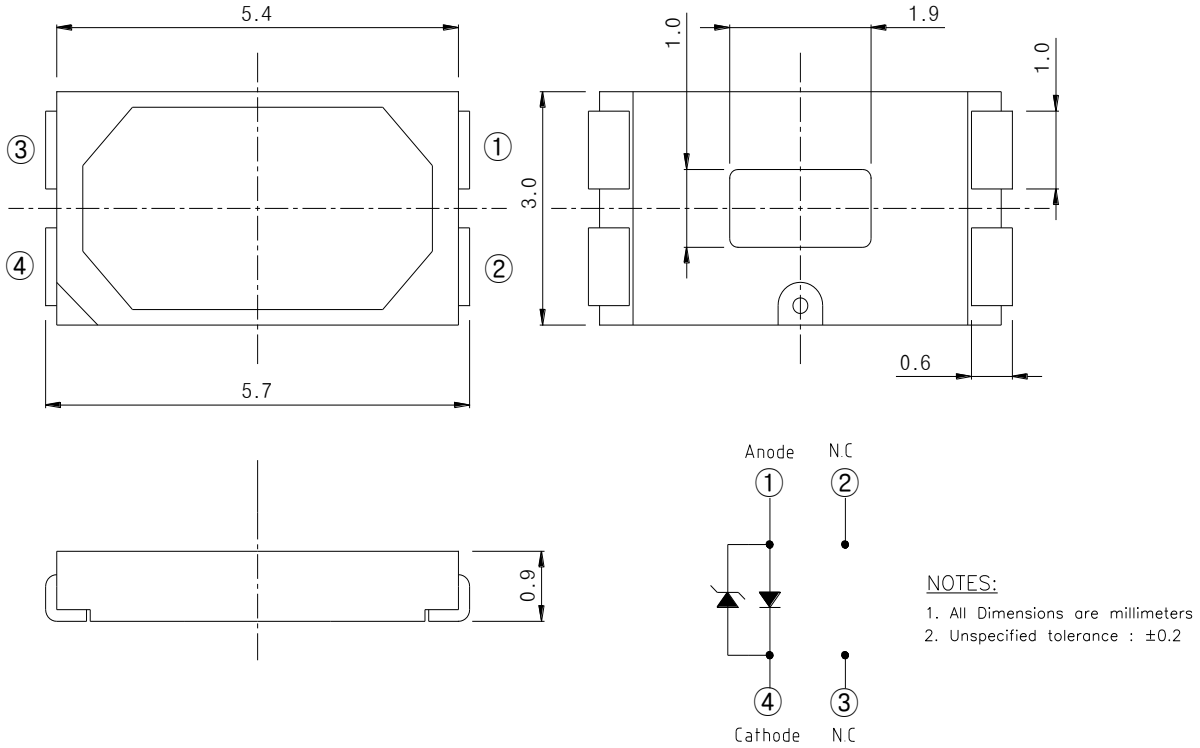

◆ Material Descriptions

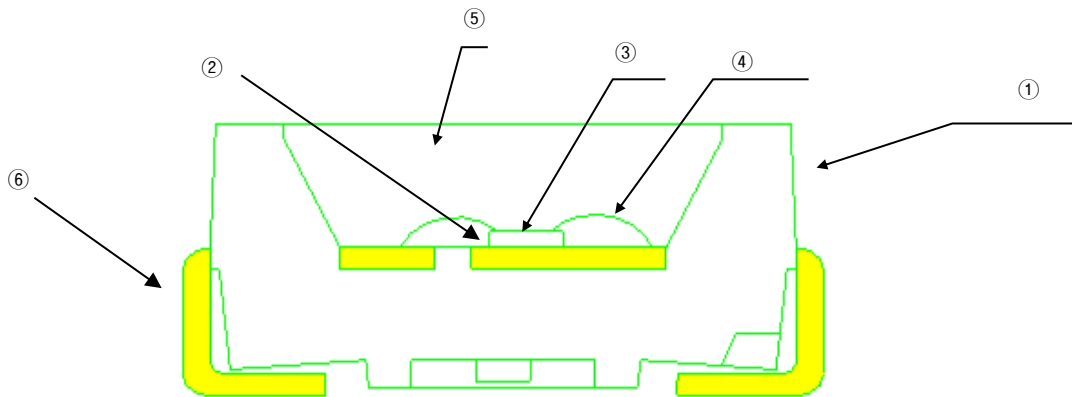

No.	Item	Material
①	Package	PA
②	Die Adhesive	Clear Silicone
③	LED Chip	InGaN
④	Wire	Au
⑤	Encapsulant	Silicone + Phosphor
⑥	Lead	Cu Alloy

The contents of this data sheet are subject to change without advance notice for the purpose of improvement. When using this product, would you please refer to the latest specifications.

5. Absolute Maximums

Item	Symbol	Min.	Max.	Unit	Conditions
Forward Current	I_F	-	80	mA	
Peak Forward Current* ¹	I_{FP}	-	160	mA	
Power Dissipation	P_D	-	272	mW	
Reverse Voltage	V_R	-	5	V	
Operating Temperature	T_{OP}	-40	85	°C	
Storage Temperature	T_S	-40	100	°C	
Soldering Temperature* ²	T_{sol}	-	260	°C	

*1. IFP was measured at $T_w \leq 1$ msec of pulse width and $D \leq 1/10$ of duty ratio.

*2. Soldering time : 5 Sec

6. Electro-Optical Characteristics ($T_A = 25^\circ\text{C}$)

Item	Symbol	Min.	Typ.	Max.	Unit	Conditions
Forward voltage* ³	V_F	2.8	3.1	3.4	V	$I_F=60\text{mA}$
Reverse Voltage	V_R	0.5	-	1.6	V	$I_F=5\text{mA}$
Luminous intensity*	I_V	7.0	7.5	-	cd	$I_F=60\text{mA}$
Color Rendering	R_a	75	-	-	-	$I_F=60\text{mA}$
Half angle* ²	$2\theta_{1/2}$	-	120	-	deg	$I_F=60\text{mA}$

*1. The luminous intensity I_V was measured at the peak of the spatial pattern which may not be aligned with the mechanical axis of the LED package.

*2. $2\theta_{1/2}$ is the off-axis where the luminous intensity is 1/2 of the peak intensity.

*3. Measuring Tolerance

- $V_F : \pm 0.05 \text{ V}$, $I_V : \pm 10\%$, $R_a : \pm 3$, $X, Y : \pm 0.01$

The contents of this data sheet are subject to change without advance notice for the purpose of improvement. When using this product, would you please refer to the latest specifications.

7. Ranks

◆ IV, V_F, Color Rank @ I_F = 60 mA

Forward Voltage [V]	Luminuous Intensity [cd]	Chromaticity	
1 : 2.8 ~ 2.9	P : 7.0 ~ 8.0	G1	F1
2 : 2.9 ~ 3.0	Q : 8.0 ~ 9.0	G2	F2
3 : 3.0 ~ 3.1	-	G3	F3
4 : 3.1 ~ 3.2	-	G4	F4
5 : 3.2 ~ 3.3	-	G5	F5
6 : 3.3 ~ 3.4	-	G6	F6
-	-	-	-

*1. KP5630W5AD29 marked as 2PF1(IV, VF, Color Rank) has the IV range 7.0~8.0cd, VF rank 2.9~3.0V and Color range F1 area.

◆ Color Coordinate Rank

G1		G2		G3		G4	
x	y	x	y	x	y	x	y
0.3207	0.3462	0.3292	0.3539	0.3212	0.3389	0.3293	0.3461
0.3212	0.3389	0.3293	0.3461	0.3217	0.3316	0.3293	0.3384
0.3293	0.3461	0.3373	0.3534	0.3293	0.3384	0.3369	0.3451
0.3292	0.3539	0.3376	0.3616	0.3293	0.3461	0.3373	0.3534
G5		G6		F1		F2	
x	y	x	y	x	y	x	y
0.3217	0.3316	0.3293	0.3384	0.3376	0.3616	0.3463	0.3687
0.3222	0.3243	0.3294	0.3306	0.3373	0.3534	0.3456	0.3601
0.3294	0.3306	0.3366	0.3369	0.3456	0.3601	0.3539	0.3669
0.3293	0.3384	0.3369	0.3451	0.3463	0.3687	0.3552	0.3760
F3		F4		F5		F6	
x	y	x	y	x	y	x	y
0.3373	0.3534	0.3456	0.3601	0.3369	0.3451	0.3448	0.3514
0.3369	0.3451	0.3448	0.3514	0.3366	0.3369	0.3440	0.3428
0.3448	0.3514	0.3526	0.3578	0.3440	0.3428	0.3514	0.3487
0.3456	0.3601	0.3539	0.3669	0.3448	0.3514	0.3526	0.3578

The contents of this data sheet are subject to change without advance notice for the purpose of improvement. When using this product, would you please refer to the latest specifications.

◆ The CIE(x, y) Chromaticity Diagram

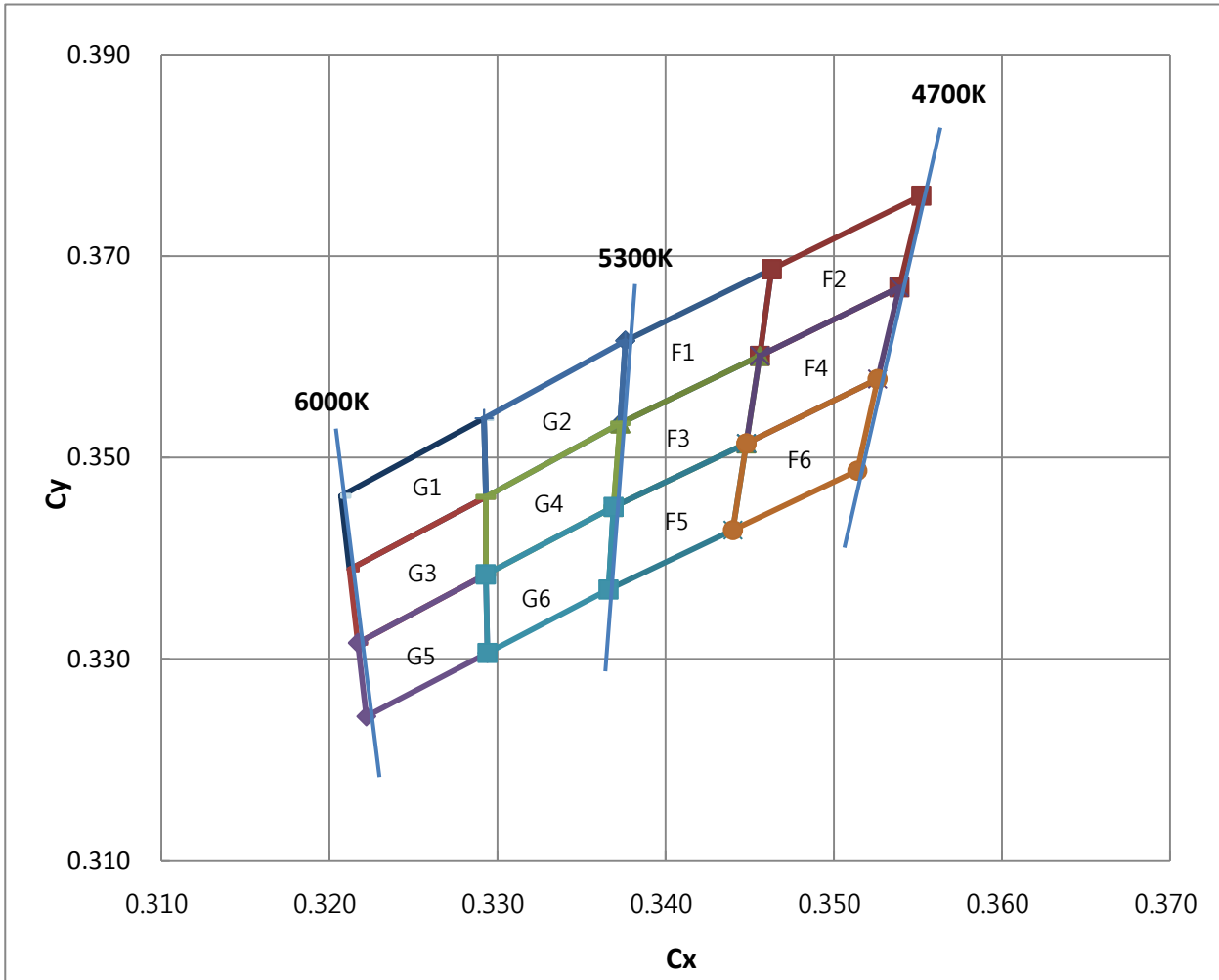

8. Part Numbering

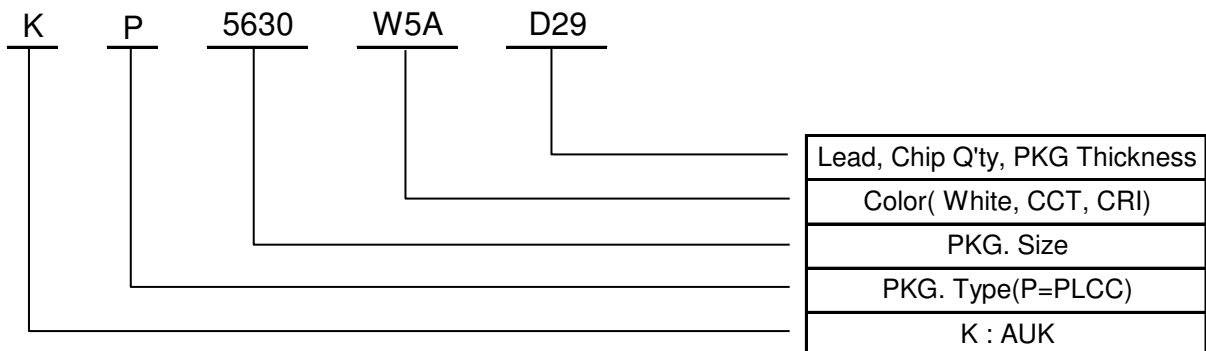

The contents of this data sheet are subject to change without advance notice for the purpose of improvement. When using this product, would you please refer to the latest specifications.

9. Characteristic Graphs

Forward current vs. Ambient temperature

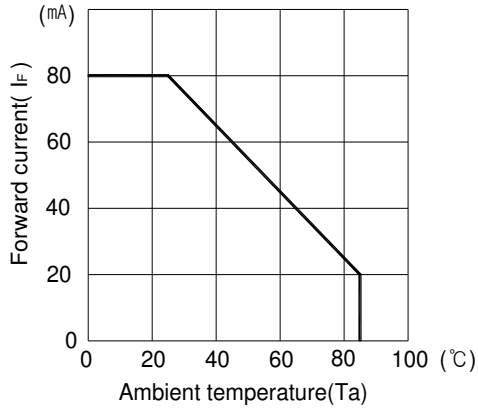

Radiant Intensity vs. Forward current

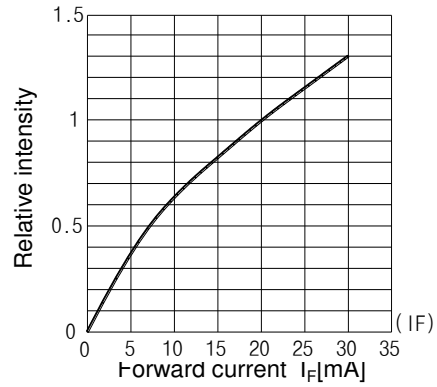

Relative radiant intensity vs. Ambient temperature

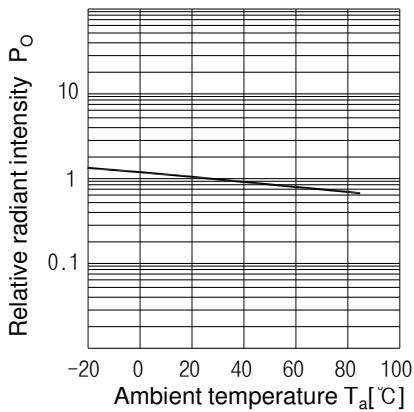

Relative intensity vs. Wavelength

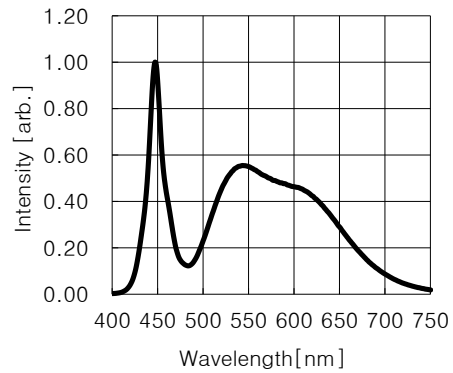

Forward current vs. Forward voltage

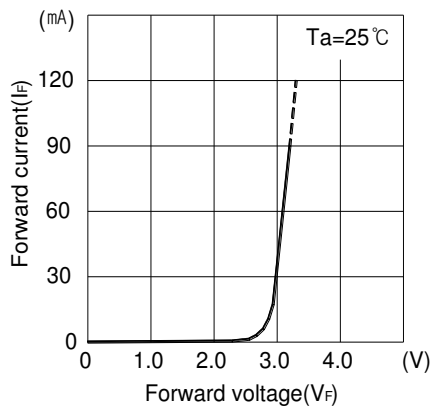

Radiant Pattern

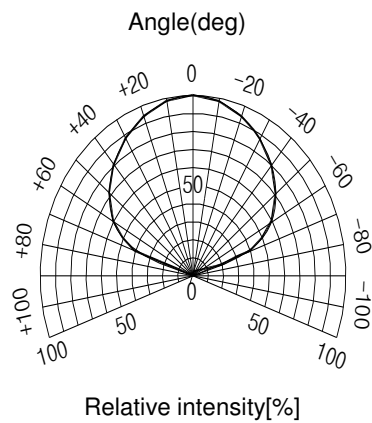

The contents of this data sheet are subject to change without advance notice for the purpose of improvement. When using this product, would you please refer to the latest specifications.