

# SPECIFICATION

ISSUED DATE : 2012.04.30

DOCUMENT NO : KLED-KP5450WxxxE7F

CUSTOMER : \_\_\_\_\_

DESCRIPTION : 5450 6 Pin Top View LED \_\_\_\_\_

MODEL NO. : KP5450WxxxE7F \_\_\_\_\_

**[ AUK CORP. ]**

ISSUE DEPT.			PRODUCTION		Q/A	
ISSUE	REVIEW	APPR'L	REVIEW	APPR'L	REVIEW	APPR'L

**[ CUSTOMER APPROVAL ]**

ISSUE	REVIEW					

**[ REVISION ]**

NO	DATE	REVISION ITEMS	ISSUED BY	APPR'D BY
O	2012.04.06	Spec. Update	K.LIM	S.M.LEE

## ■ Contents

- ◆ PL
  - 1 . Descriptions
  - 2 . Features
  - 3 . Applications
  - 4 . Outline Dimensions and Material Descriptions
  - 5 . Absolute Maximums
  - 6 . Elector-Optical Characteristics
  - 7 . Ranks
  - 8 . Part Numbering
  - 9 . Characteristic Graphs
  - 10 . Reliability Test
  - 11 . Recommended Soldering Pattern
  - 12 . Reflow Soldering Profile
  - 13 . Manual Soldering Conditions
  - 14 . Tape and Reel Specifications
  - 15 . Packing Specifications
  - 16 . Label
  - 17 . Cautions

---

◆ PL

This specification sheets include the contents under the copyright of KODENSHI AUK CORP("AUK'). Please keep them with reasonable care as important information. Please don't reproduce or cause anyone reproduce them without AUK's consent.

**AUK takes no responsibility for damage caused by improper use of the devices which does not meet the conditions and absolute maximum ratings to be used specified in the relevant specification sheet.**

Please obey the instructions mentioned below for actual use of this device.

① This device is designed for general electronic equipment.

Main use of this device are as follows;

- \* Computer \* OA equipment \* Telecommunication equipment(Terminal)
- \* Measuring instrument \* Machine tool \*Industrial robot
- \* AV equipment \* Home appliance,etc.

② Please take proper steps in order to maintain reliability and safety, in case this device is used for the uses mentioned below which require high reliability.

- \* Unit concerning control and safety of a vehicle (air plane,train,automobile, etc.)
- \* Traffic signal \* Gas leak detection breaker
- \* Fire box and burglar alarm box \* Other safety equipment,etc.

③ Please don't use for the uses mentioned below which require extremely high reliability.

- \* Space equipment \* Telecommunication equipment(Trunk)
- \* Nuclear control equipment \* Medical equipment(relating to any fatal element),etc.

## 1. Descriptions

The KP5450WxxxE7F is a White LED consisting of small and thin form plastic leaded chip carrier (PLCC) 6-pin package, InGaN blue chip and phosphor.

## 2. Features

- ◆ Small Footprint Surface Mount Package ( 5.4 L × 5.0 W × 1.6 H [mm])
- ◆ Typical Forward Voltage( $V_F$ ) : 3.2 V @ Forward Current( $I_F$ )=60mA
- ◆ Operation Temperature from -30°C to +85°C
- ◆ Soldering methods : IR reflow soldering
- ◆ Taping : 12mm conductive black carrier tape & antistatic clear cover tape

## 3. Applications

- ◆ General lighting
- ◆ Interior lighting
- ◆ Indoor and out door displays
- ◆ Architectural / Decorative lighting

**4. Outline Dimensions and Material Descriptions**

◆ Outline Dimensions

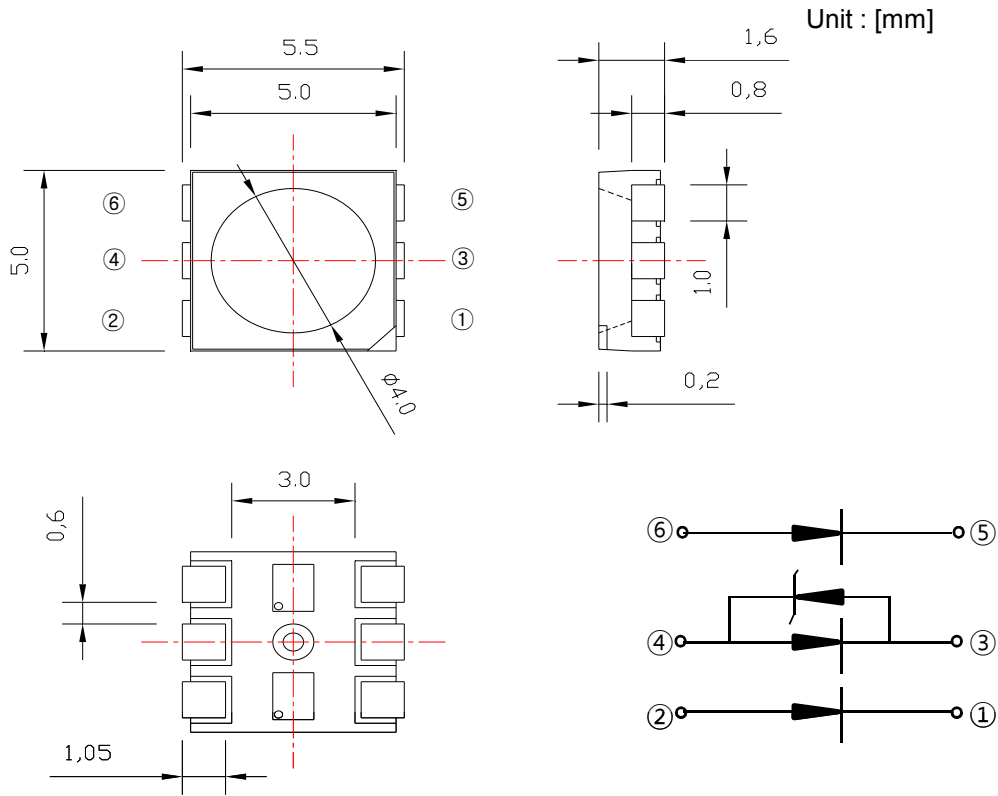

◆ Material Descriptions

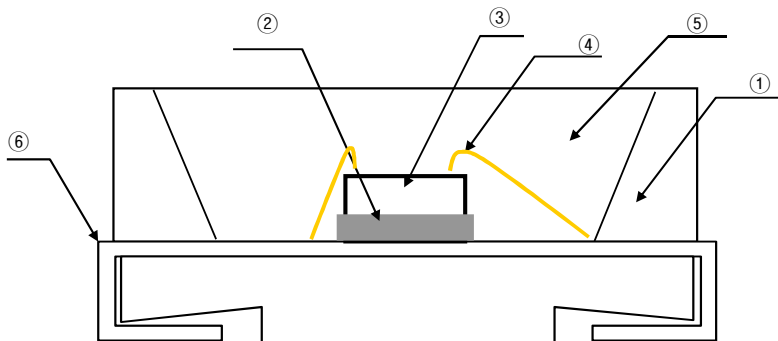

No.	Item	Material
①	Package	PPA
②	Die Adhesive	Clear Sillicone
③	LED Chip	InGaN
④	Wire	Au
⑤	Encapsulant	Silicone + Phosphor
⑥	Lead	Cu Alloy

## 5. Absolute Maximums

Parameter	Symbol	Ratings	Unit
Forward current	$I_F$	30/each	mA
Pulse forward current <sup>*1</sup>	$I_{FP}$	0.1/each	A
Power dissipation	$P_D$	315	mW
Operating temperature	$T_{opr.}$	-30 ~ +85	°C
Storage temperature	$T_{stg.}$	-40 ~ +100	°C
Soldering Temperature <sup>*2</sup>	$T_{sol.}$	260	°C

\*1. IFP was measured at  $T_w \leq 1$  msec of pulse width and  $D \leq 1/10$  of duty ratio.

\*2. Soldering time : 5 Sec

## 6. Electro-Optical Characteristics ( $T_A = 25^\circ\text{C}$ )

Parameter	Symbol	Conditions	Min	Typ	Max	Unit
Forward voltage	$V_F$	$I_F=60\text{mA}$	-	3.2	3.4	V
Reverse Current	$I_R$	$V_R = 5 \text{ V}$	-	-	10	$\mu\text{A}$
Luminance Flux	$\Phi_v$	$I_F=60\text{mA}$	-	19.0	-	lm
Luminance Efficiency	-	$I_F=60\text{mA}$	-	95.0	-	lm/W
Luminance Intensity <sup>*1</sup>	$I_v$	$I_F=60\text{mA}$	5.5	7.5	-	cd
Color Coordinate	x	$I_F=60\text{mA}$	0.266	-	0.360	-
	y		0.236	-	0.400	
Half angle <sup>*2</sup>	$2\Delta\theta_{1/2}$	$I_F=60\text{mA}$	-	120	-	deg.

\*1. The luminous intensity  $I_v$  was measured at the peak of the spatial pattern which may not be aligned with the mechanical axis of the LED package.

\*2.  $2\theta_{1/2}$  is the off-axis where the luminous intensity is 1/2 of the peak intensity.

3. Measuring Tolerance

-  $V_F : \pm 0.1 \text{ V}$ ,  $I_v : \pm 10\%$ , CRI :  $\pm 3$ , X,Y :  $\pm 0.01$

## 7. Ranks

◆ IV,  $V_F$ , Color Rank @  $I_F = 60 \text{ mA}$

Forward Voltage [V]	Luminous Intensity [cd]	CRI
1 : ~3.0	B : 5.5~6.0	MIN 70
2 : 3.0 ~ 3.1	C : 6.0 ~ 6.5	
3 : 3.1 ~ 3.2	D : 6.5 ~ 7.0	
4 : 3.2 ~ 3.3	E : 7.0 ~ 7.5	
5 : 3.3~3.4	F : 7.5 ~ 8.0	
<del>        </del>	G : 8.0~	

◆ Color Coordinate Rank

A		B		C		D	
2700K		3000K		3500K		4000K	
0.4813	0.4319	0.4562	0.426	0.4299	0.4165	0.4006	0.4044
0.4562	0.426	0.4299	0.4165	0.3996	0.4015	0.3736	0.3874
0.4373	0.3893	0.4147	0.3814	0.3889	0.369	0.367	0.3578
0.4593	0.3944	0.4373	0.3893	0.4147	0.3814	0.3898	0.3716

E		F		G		H	
4500K		5000K		5700K		6500K	
0.3736	0.3874	0.3551	0.376	0.3376	0.3616	0.3205	0.3481
0.3548	0.3736	0.3376	0.3616	0.3207	0.3462	0.3028	0.3304
0.3512	0.3465	0.3366	0.3369	0.3222	0.3243	0.3068	0.3113
0.367	0.3578	0.3515	0.3487	0.3366	0.3369	0.3221	0.3261

◆ The CIE(x, y) Chromaticity Diagram

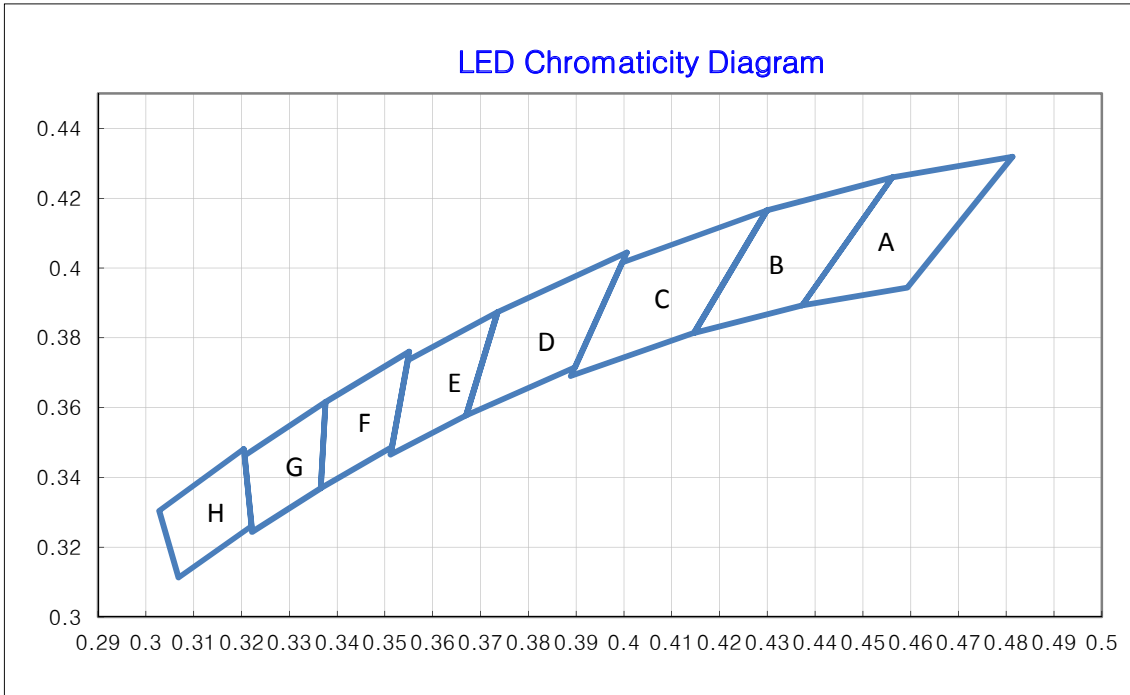

**8. Part Numbering**

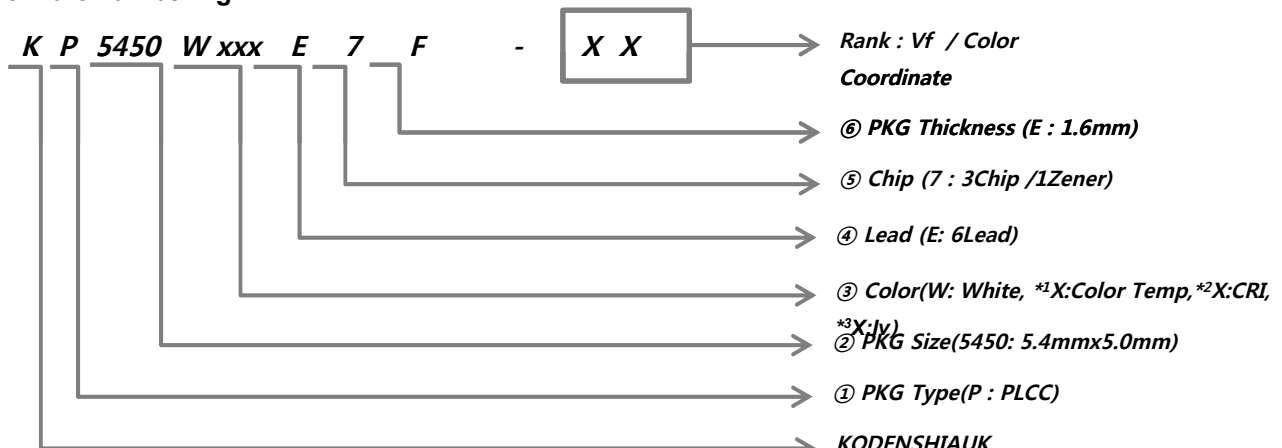

\*1 : 색온도 Rank Table

Rank	Color Temp	Range
2	2700K	2580 ~ 2870K
A	3000K	2870 ~ 3220K
3	3500K	3220 ~ 3710K
B	4000K	3710 ~ 4260K
4	4500K	4260 ~ 4746K
C	5000K	4746 ~ 5311K
5	5700K	5311 ~ 6020K
6	6500K	6020 ~ 7040K
7	7500K	7040 ~ 8000K

\*2 : CRI Rank Table

Rank	Iv(cd)
6	70 under
7	70 ~ 75
A	75~80
8	80~85
B	85~90
9	90 Over

\*3 : Iv Rank Table

Rank	Iv(cd)
A	5.0 ~ 5.5
B	5.5 ~ 6.0
C	6.0 ~ 6.5
D	6.5 ~ 7.0
E	7.0 ~ 7.5
F	7.5 ~ 8.0
G	8.0 ~

## 9. Characteristic Graphs

**Forward current vs. Ambient temperature**

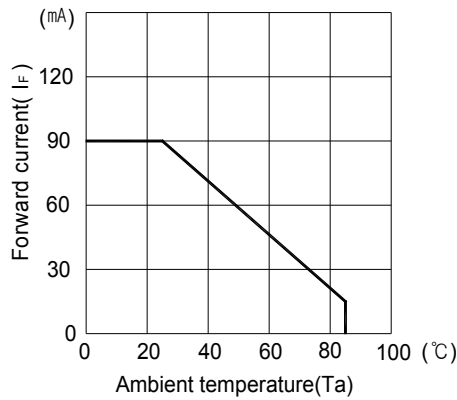

**Luminous Intensity vs. Forward current**

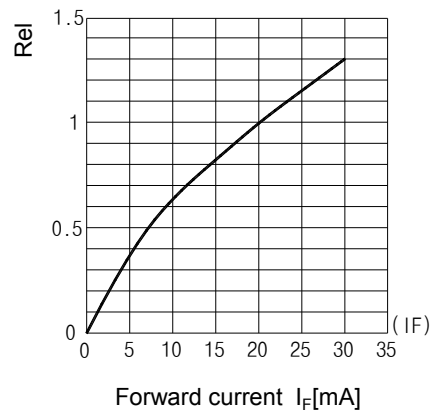

**Relative luminous intensity vs. Ambient temperature**

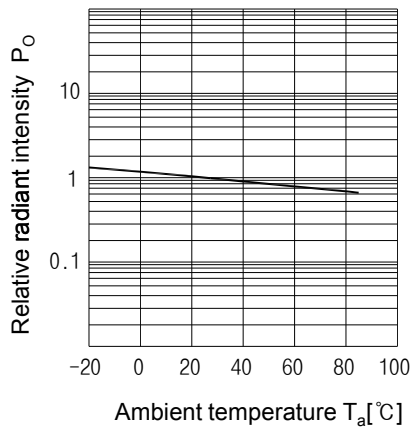

**Relative intensity vs. Wavelength**

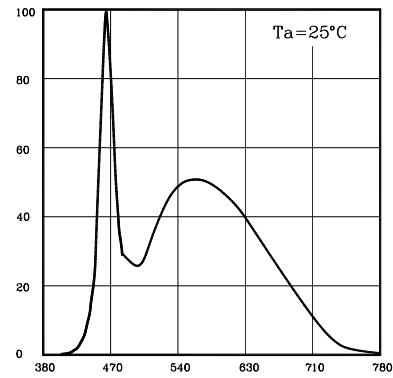

**Forward current vs. Forward voltage**

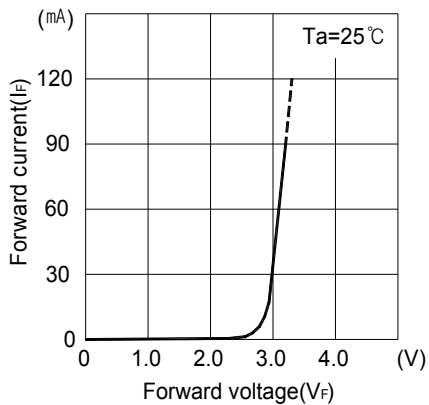

**Viewing Pattern**

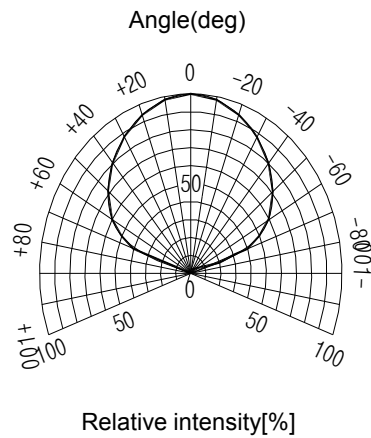

## 10. Reliability Test

### ◆ Criteria

Item	Symbol	Test Conditions	Criteria for Judgement	
			Min.	Max.
Forward Voltage	$V_F$	$I_F = 60\text{mA}$	-	U.S.L. $\times$ 1.2
Reverse Current	$I_R$	$V_R = 5\text{V}$	-	U.S.L. $\times$ 2.0
Luminous Intensity	$I_V$	$I_F = 60\text{mA}$	$I \times 0.5$	-

U.S.L. : Upper Spec Limit, L.S.L. : Lower Spec Limit, I : Initial Value

### ◆ Test Conditions

No.	Test Item	Standard Test Method	Test Conditions	Note	#of Damaged/ Test No.
1	Resistance to Solder Heat (Reflow Soldering)	JEITA ED-4701 300 301	$T_{\text{slid}} = 260^\circ\text{C}$ , 10sec.	2 time	0/22
2	Temperature Cycle	JEITA ED-4701 100 105	$-40^\circ\text{C} \sim 100^\circ\text{C}$ 30min., 30min.	100 Cycles	0/22
3	High Temperature Storage	JEITA ED-4701 200 201	$T_a = 100^\circ\text{C}$	500 hrs.	0/22
4	Temperature Humidity Storage	JEITA ED-4701 100 103	$T_a = 60^\circ\text{C}$ , RH=90%	500 hrs.	0/22
5	Low Temperature Storage	JEITA ED-4701 200 202	$T_a = -40^\circ\text{C}$	500 hrs.	0/22
6	Steady State Operating Life	-	$T_a = 25^\circ\text{C}$ , $I_F = 90\text{mA}$	500 hrs.	0/22
7	Steady State Operating Life of Low Temperature	-	$T_a = -40^\circ\text{C}$ , $I_F = 10\text{mA}$	500 hrs.	0/22
8	Steady State Operating Life of High Temperature	-	$T_a = 85^\circ\text{C}$ , $I_F = 20\text{mA}$	500 hrs.	0/22
9	Steady State Operating Life of High Humidity Heat	-	$T_a = 60^\circ\text{C}$ , RH=90%, $I_F = 50\text{mA}$	500 hrs.	0/22

**11. Recommended Soldering Pattern**

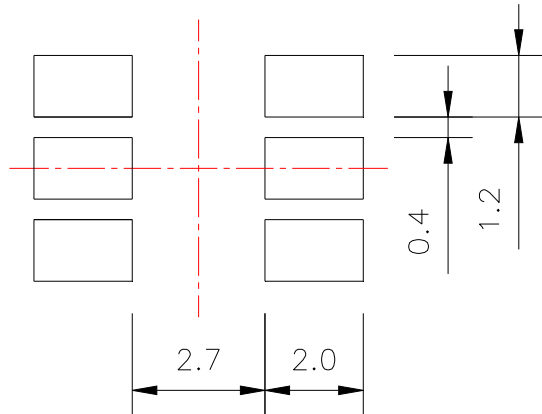

Unit : [mm]

**12. Reflow Soldering Profile**

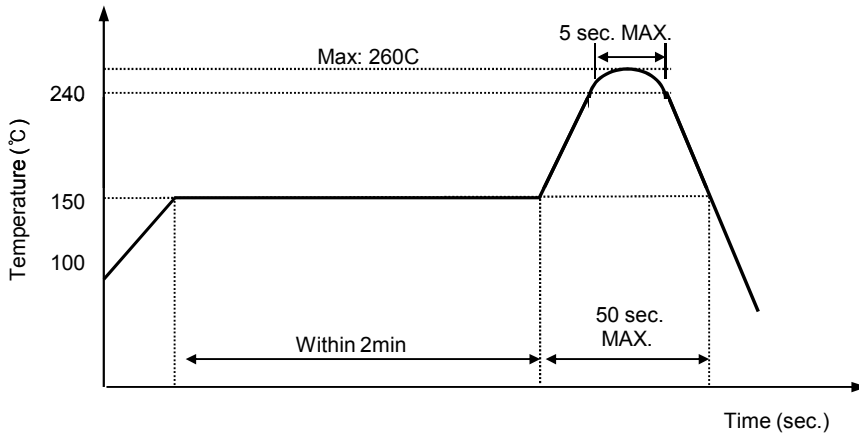

**13. Manual Soldering Codition**

For manual soldring, you have to complete soldring within 3 seconds under 260 °C.  
 (The temperature at tip of solder iron).

## 14. Tape and Reel Specifications

### ◆ Tape

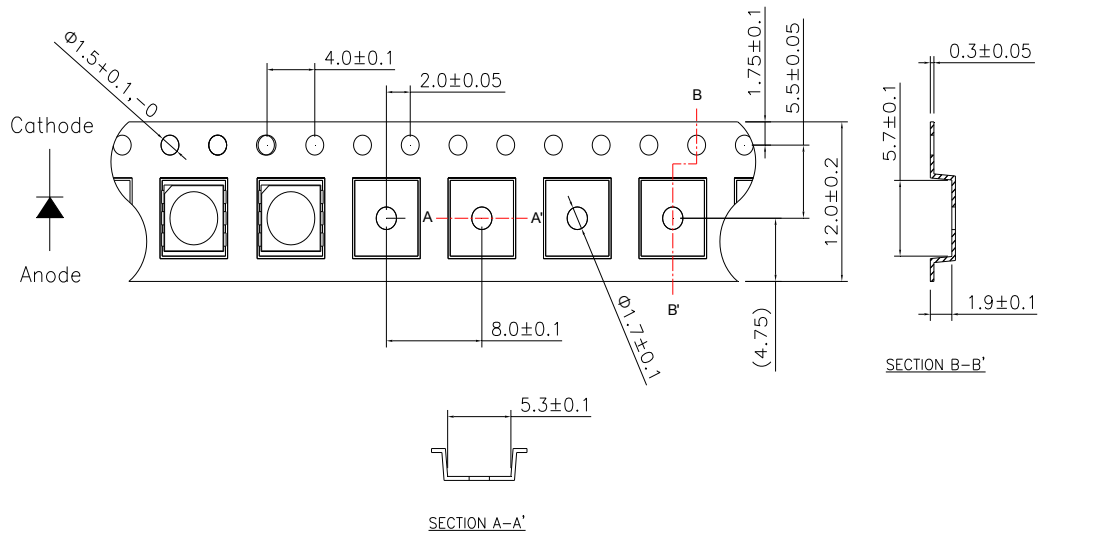

### ◆ Wheel

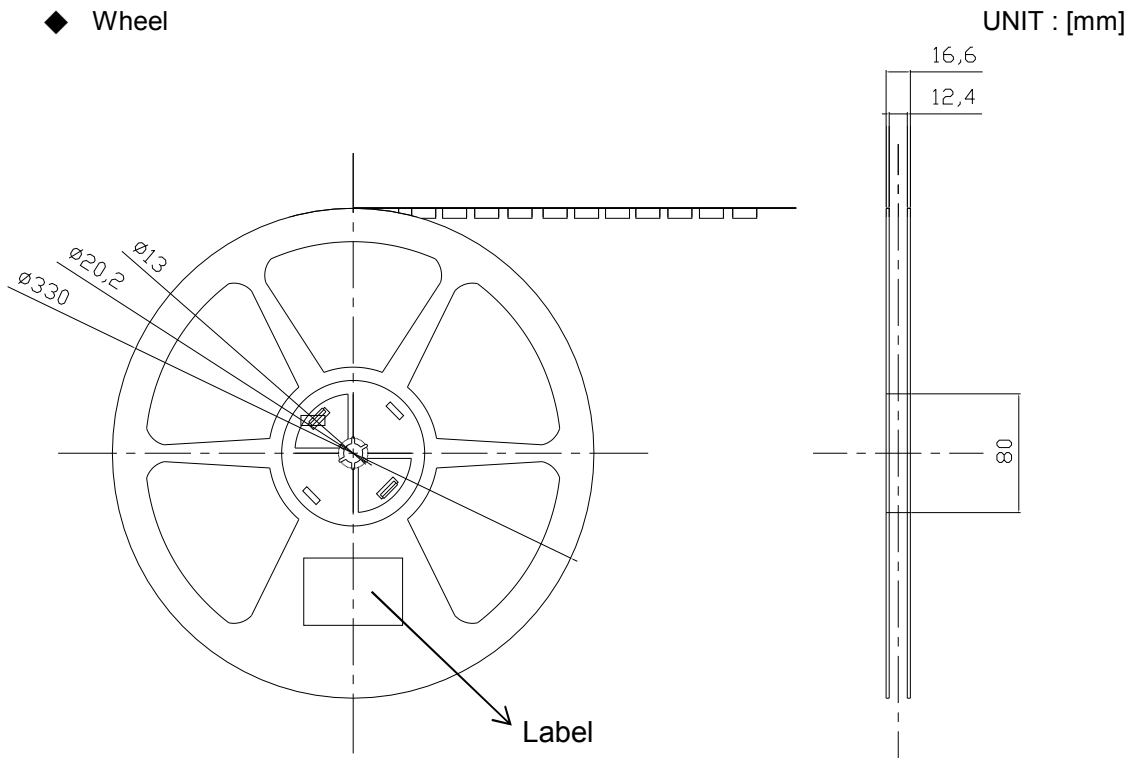

- ◆ Quantity : 4,000pcs/Wheel
- ◆ Cover Tape Adhesion : 0.1 ~ 0.7N for 45° pulling up.

**15. Packing Specifications**

UNIT : [mm]

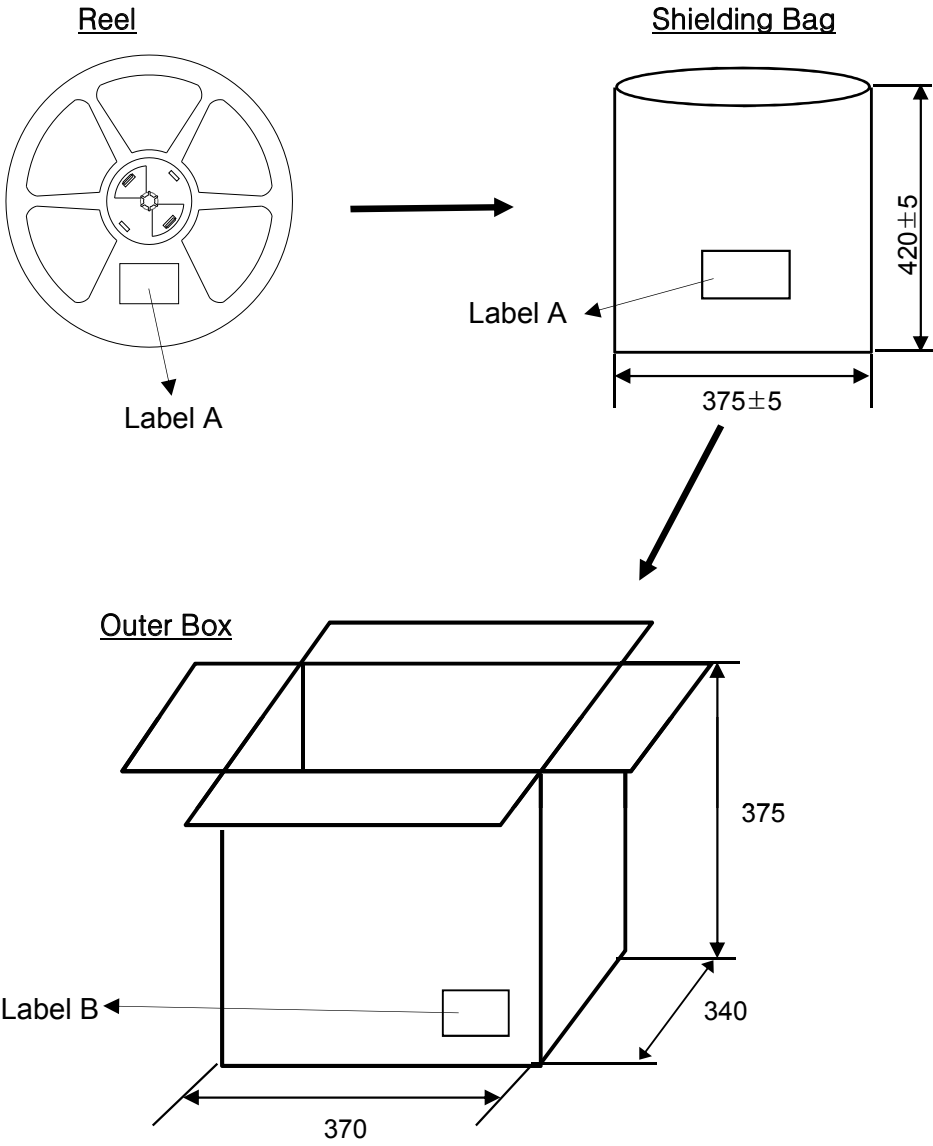

- ◆ Quantity : 60,000pcs/Out Box
- ◆ Specifications of Carrier Tape, Reel and Shilding Bag

Item	Carrier Tape	Reel	Shilding Bag	
			Outside	Inside
Surface Conductivity	$1 \times 10^4 \sim 1 \times 10^6$	$1 \times 10^8$	$1 \times 10^{10} \sim 1 \times 10^{12}$	$1 \times 10^{11} \sim 1 \times 10^{13}$

## 16. Label

### ◆ Label A



### ◆ Label B



## 17. Cautions

### ◆ Cautions in Usage

- Store and use where there is no exterior force that will cause change in shape.
- Store and use where there is no Hydrogen Sulfide gas, or any other corrosive gas.
- Once the package is opened, the products should be used within 3 days. Otherwise, they should be kept in a damp proof box with desiccating agent. Considering the tape life, we suggest our customers to use our products within a year(from production date)
- If opened more than 3 days in an atmosphere 5 °C ~35 °C, RH 60%, they should be treated at 60 °C ±5 °C for 15 hrs.
- Solder the lead pin under conditions of the absolute maximum rating chart and do not apply force on the solder pin after soldering.

### ◆ Guarantee Period and Scope

- Period  
One year after delivery to the desired place.
- Scope  
Replacement of products will be done if any problems lie in our company's products. However, we are not liable for your damage due to lack of caution.

### ◆ Others

- Any doubts concerning this specification should be discussed fully by both parties.