

# SPECIFICATION

ISSUED DATE : 2011.12.21

DOCUMENT NO : KLED-KP5450B45E7F

CUSTOMER : \_\_\_\_\_

DESCRIPTION : 5450 6 Pin Top View LED \_\_\_\_\_

MODEL NO. : KP5450B45E7F \_\_\_\_\_

**[ AUK CORP. ]**

ISSUE DEPT.			PRODUCTION		Q/A	
ISSUE	REVIEW	APPR'L	REVIEW	APPR'L	REVIEW	APPR'L

**[ CUSTOMER APPROVAL ]**

ISSUE	REVIEW					

**[ REVISION ]**

NO	DATE	REVISION ITEMS	ISSUED BY	APPR'D BY
0	2011.12.21	Spec. Update	K.LIM	SM.LEE

**■ Contents**

- ◆ PL
  - 1 . Descriptions
  - 2 . Features
  - 3 . Applications
  - 4 . Outline Dimensions and Material Descriptions
  - 5 . Absolute Maximums
  - 6 . Elector-Optical Characteristics
  - 7 . Ranks
  - 8 . Part Numbering
  - 9 . Characteristic Graphs
  - 10 . Recommended Soldering Pattern
  - 11 . Reflow Soldering Profile
  - 12 . Manual Soldering Conditions
  - 13 . Tape and Reel Specifications
  - 14 . Packing Specifications
  - 15 . Label
  - 16 . Cautions

## ◆ PL

This specification sheets include the contents under the copyright of KODENSHI AUK CORP("AUK"). Please keep them with reasonable care as important information. Please don't reproduce or cause anyone reproduce them without AUK's consent.

**AUK takes no responsibility for damage caused by improper use of the devices which does not meet the conditions and absolute maximum ratings to be used specified in the relevant specification sheet.**

Please obey the instructions mentioned below for actual use of this device.

① This device is designed for general electronic equipment.

Main use of this device are as follows;

- \* Computer \* OA equipment \* Telecommunication equipment(Terminal)
- \* Measuring instrument \* Machine tool \*Industrial robot
- \* AV equipment \* Home appliance,etc.

② Please take proper steps in order to maintain reliability and safety, in case this device is used for the uses mentioned below which require high reliability.

- \* Unit concerning control and safety of a vehicle (air plane,train,automobile, etc.)
- \* Traffic signal \* Gas leak detection breaker
- \* Fire box and burglar alarm box \* Other safety equipment,etc.

③ Please don't use for the uses mentioned below which require extremely high reliability.

- \* Space equipment \* Telecommunication equipment(Trunk)
- \* Nuclear control equipment \* Medical equipment(relating to any fatal element),etc.

## 1. Descriptions

The KP5450B45E7F is a LED consisting of small and thin form plastic leaded chip carrier (PLCC) 6-pin package, InGaN blue chip.

## 2. Features

- ◆ Small Footprint Surface Mount Package ( 5.4 L × 5.0 W × 1.6 H [mm])
- ◆ Typical Forward Voltage( $V_F$ ) : 3.2 V @ Forward Current( $I_F$ )=60mA
- ◆ Operation Temperature from -30°C to +85°C
- ◆ Soldering methods : IR reflow soldering
- ◆ Taping : 12mm conductive black carrier tape & antistatic clear cover tape

## 3. Applications

- ◆ Vegetative lighting
- ◆ Interior lighting
- ◆ Indoor and out door displays
- ◆ Architectural / Decorative lighting

**4. Outline Dimensions and Material Descriptions**

◆ Outline Dimensions

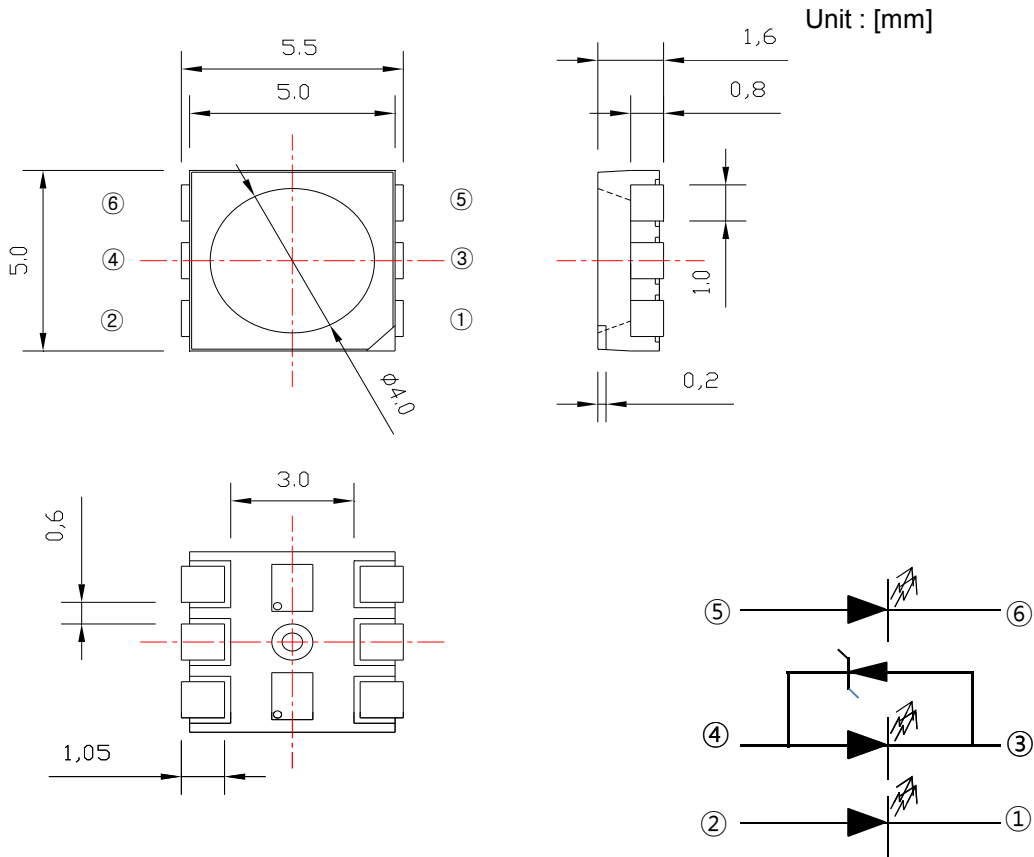

◆ Material Descriptions

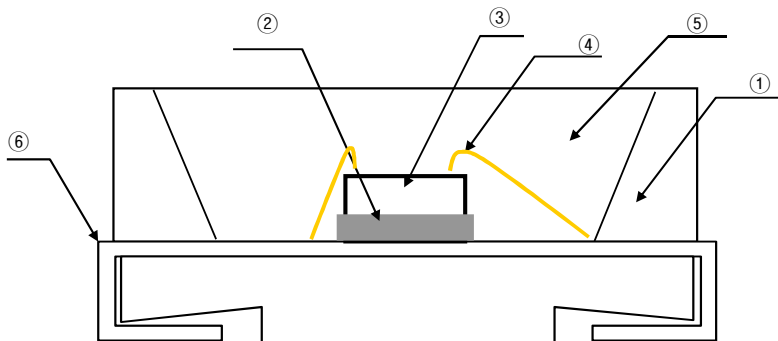

No.	Item	Material
①	Package	PPA
②	Die Adhesive	Clear Sillicone
③	LED Chip	InGaN
④	Wire	Au or Ag
⑤	Encapsulant	Silicone
⑥	Lead	Cu Alloy

## 5. Absolute Maximums

Parameter	Symbol	Ratings	Unit
Forward current	$I_F$	30/each	mA
Pulse forward current <sup>*1</sup>	$I_{FP}$	0.1/each	A
Power dissipation	$P_D$	315	mW
Operating temperature	$T_{opr.}$	-30 ~ +85	°C
Storage temperature	$T_{stg.}$	-40 ~ +100	°C
Soldering Temperature <sup>*2</sup>	$T_{sol.}$	260	°C

\*1. IFP was measured at  $T_w \leq 1$  msec of pulse width and  $D \leq 1/10$  of duty ratio.

\*2. Soldering time : 5 Sec

## 6. Electro-Optical Characteristics ( $T_A = 25^\circ\text{C}$ )

Parameter	Symbol	Conditions	Min	Typ	Max	Unit
Forward voltage / each <sup>*3</sup>	$V_F$	$I_F=60\text{mA}$	-	3.2	3.5	V
Reverse Current	$I_R$	$V_R = 5\text{ V}$	-	-	10	$\mu\text{A}$
Wavelength	$I_v$	$I_F=60\text{mA}$	450.0		460.0	nm
Luminance Intensity <sup>*1</sup>	$I_v$	$I_F=60\text{mA}$	600	750	-	mcd
Half angle <sup>*2</sup>	$2\Delta\theta_{1/2}$	$I_F=60\text{mA}$	-	120	-	deg.

\*1. The luminous intensity  $I_v$  was measured at the peak of the spatial pattern which may not be aligned with the mechanical axis of the LED package.

\*2.  $2\theta_{1/2}$  is the off-axis where the luminous intensity is 1/2 of the peak intensity.

\*3. Measuring Tolerance

-  $V_F : \pm 0.1\text{ V}$ ,  $I_v : \pm 10\%$ ,  $R_a : \pm 3$ ,  $X, Y : \pm 0.01$

7. Ranks

◆ IV, V<sub>F</sub>, Color Rank @ I<sub>F</sub> = 60 mA

Rank Table		
Forward Voltage [V]	Luminuous Intensity [mcd]	Wavelength(nm)
1 : 2.9 ~ 3.1	P : 600 ~ 700	a : 450 ~ 455
2 : 3.1 ~ 3.3	Q : 700 ~ 800	b : 455 ~ 460
3 : 3.3 ~ 3.5	R : 800 ~ 1000	X

8. Part Numbering

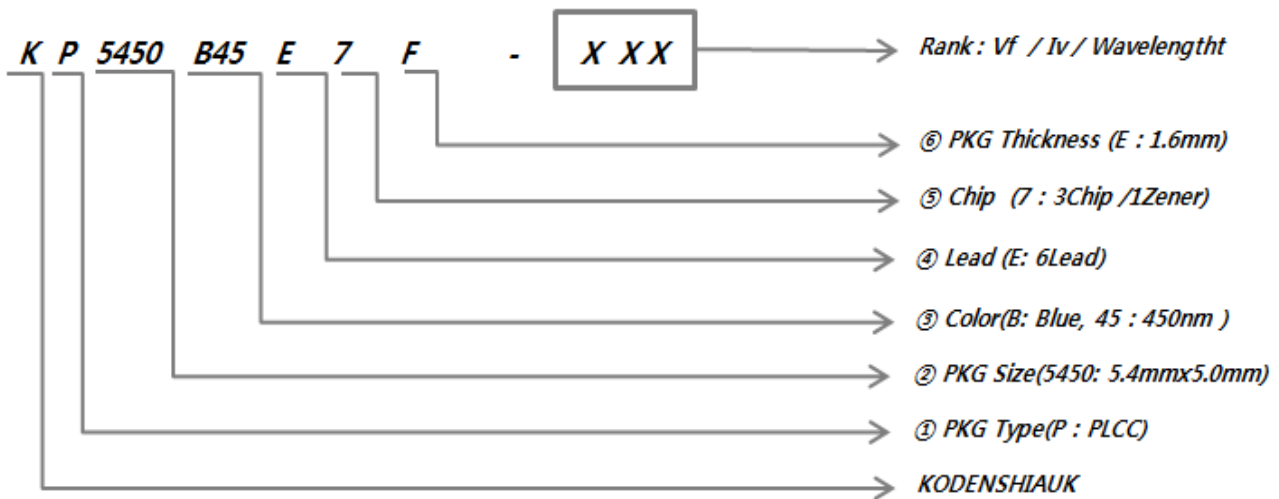

9. Characteristic Graphs

**Forward current vs. Ambient temperature**

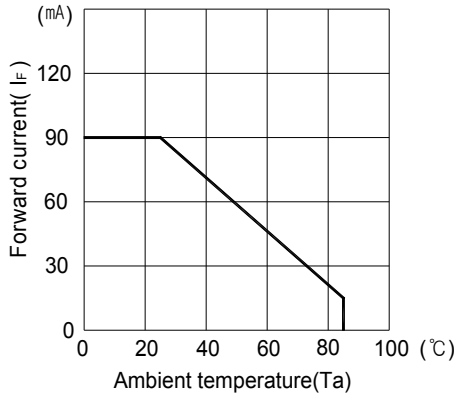

**Luminous Intensity vs. Forward current**

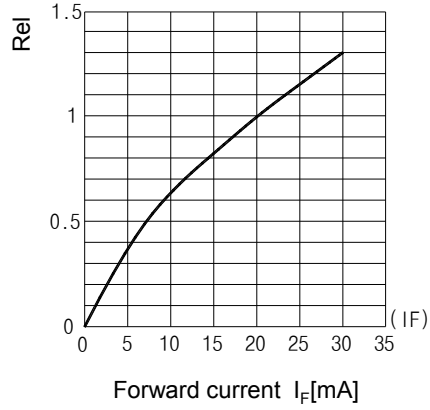

**Relative luminous intensity vs. Ambient temperature**

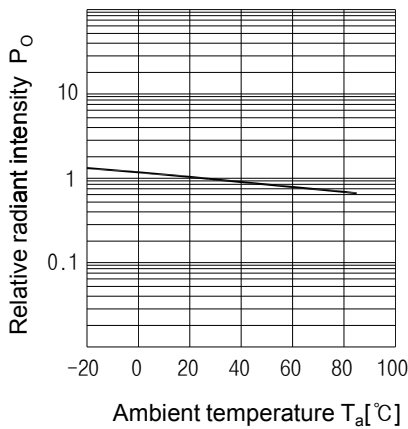

**Relative intensity vs. Wavelength**

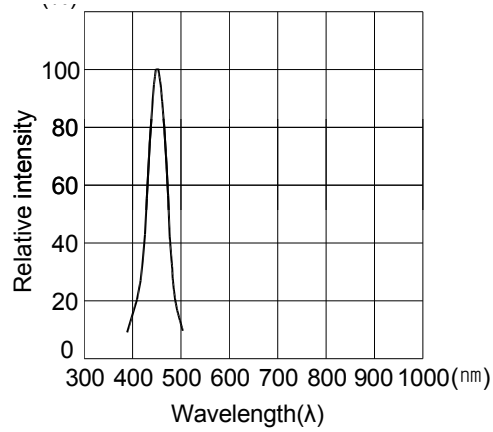

**Forward current vs. Forward voltage**

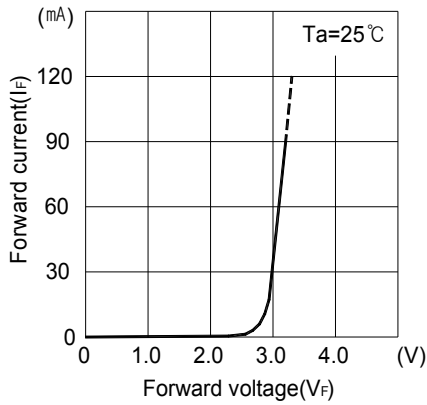

**Viewing Pattern**

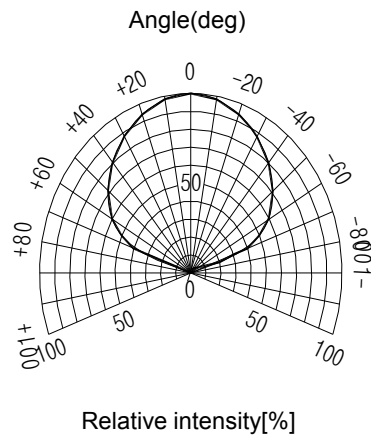

**10. Recommended Soldering Pattern**

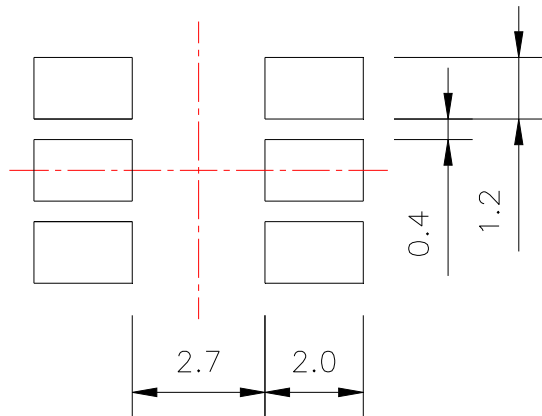

Unit : [mm]

**11. Reflow Soldering Profile**

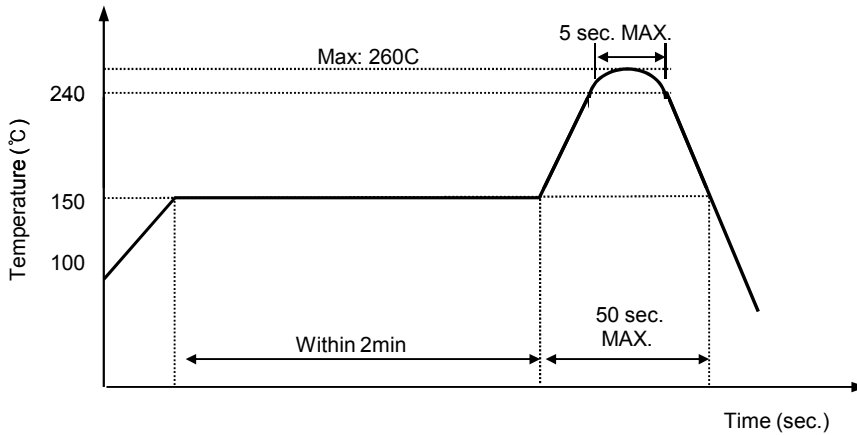

**12. Manual Soldering Codition**

For manual soldring, you have to complete soldring within 3 seconds under 260 °C.  
 (The temperature at tip of solder iron).

### 13. Tape and Reel Specifications

◆ Tape

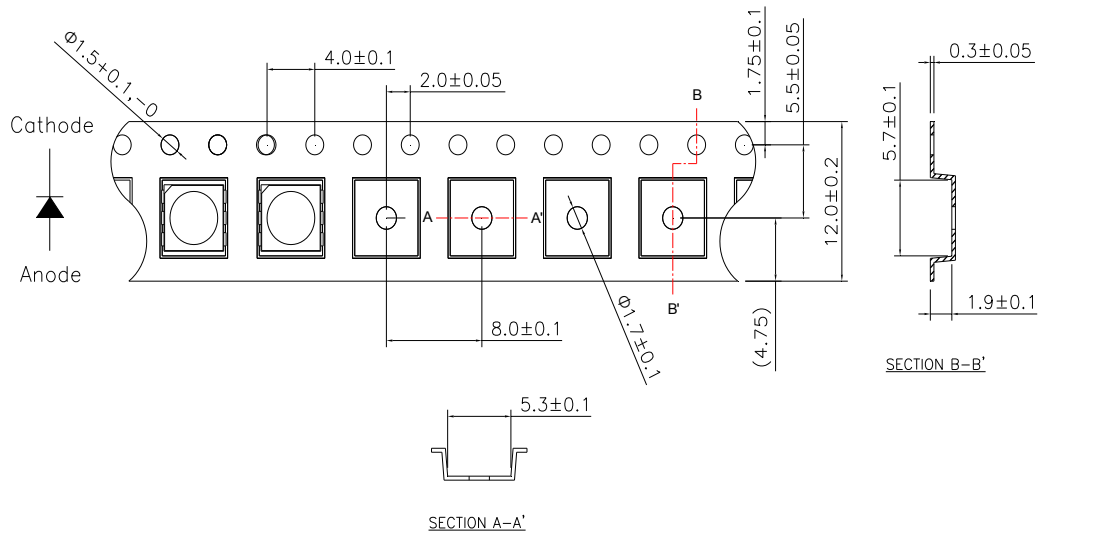

◆ Reel

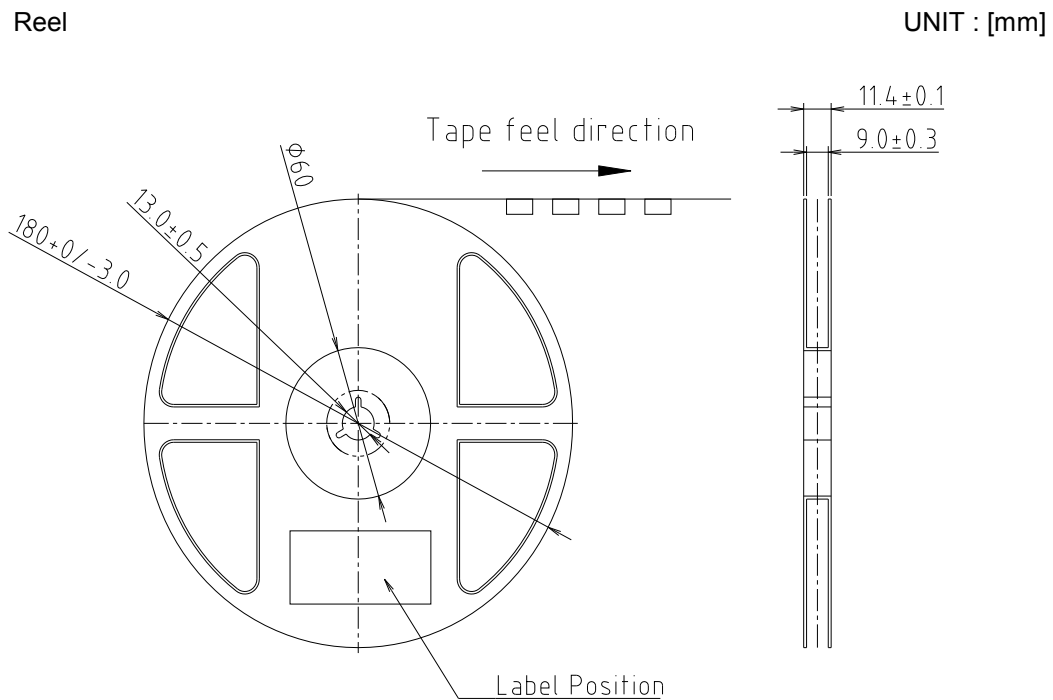

- ◆ Quantity : 1,000pcs/Reel
- ◆ Cover Tape Adhesion : 0.1 ~ 0.7N for 45° pulling up.

14. Packing Specifications

UNIT : [mm]

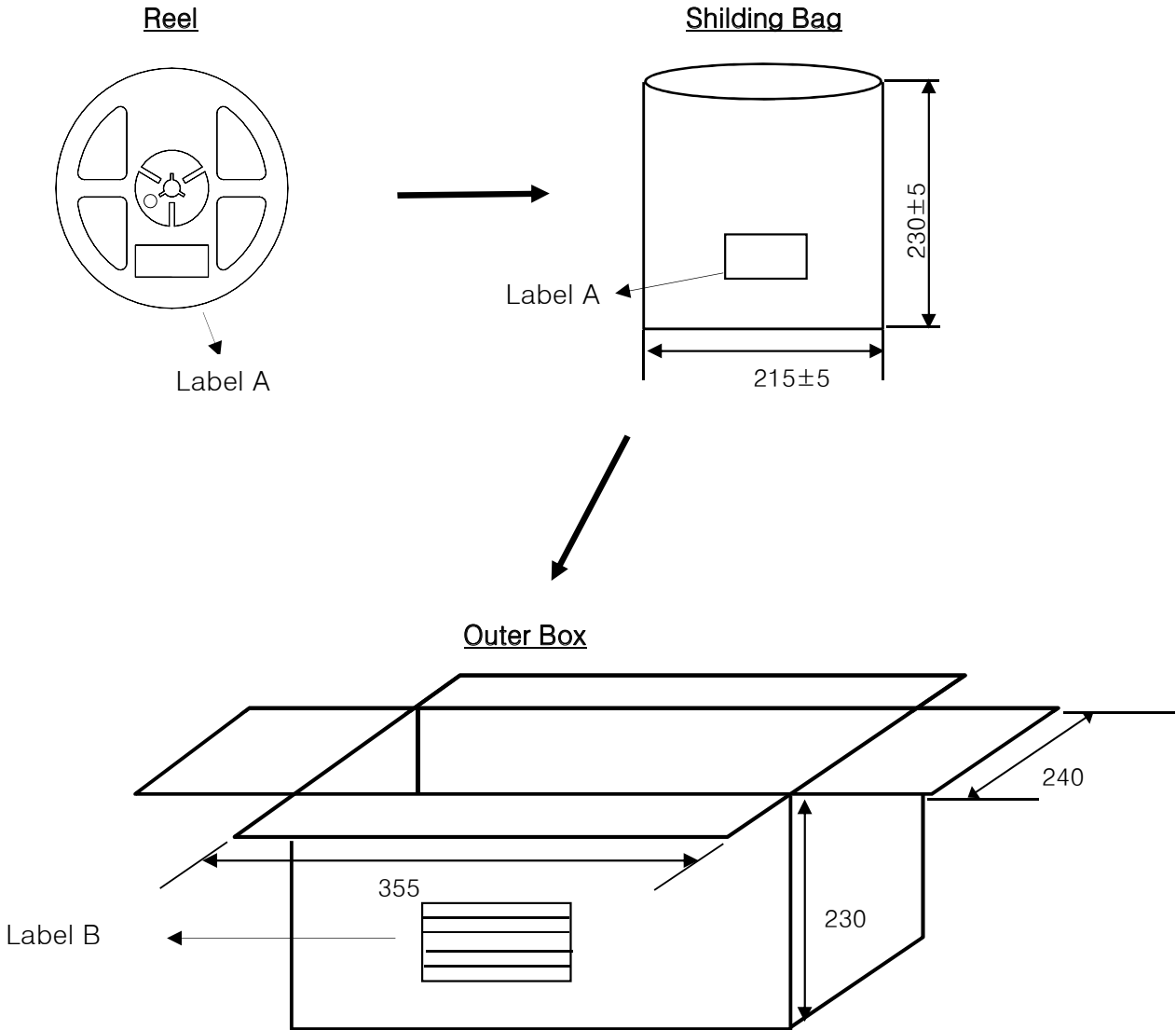

◆ Specifications of Carrier Tape, Reel and Shilding Bag

Item	Carrier Tape	Reel	Shilding Bag	
			Outside	Inside
Surface Conductivity	$1 \times 10^4 \sim 1 \times 10^6$	$1 \times 10^8$	$1 \times 10^{10} \sim 1 \times 10^{12}$	$1 \times 10^{11} \sim 1 \times 10^{13}$

15. Label

◆ Label A

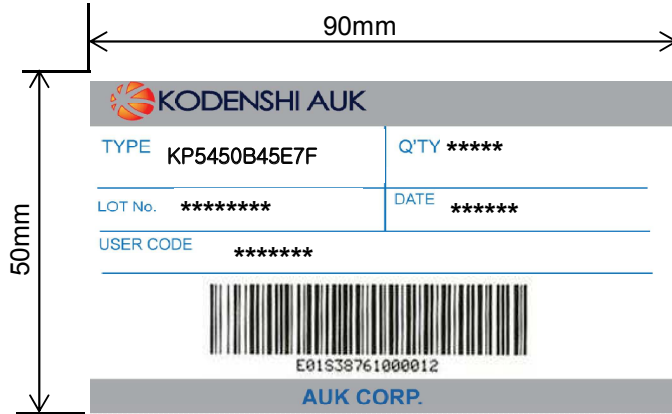

◆ Label B



## 16. Cautions

### ◆ Cautions in Usage

- Store and use where there is no exterior force that will cause change in shape.
- Store and use where there is no Hydrogen Sulfide gas, or any other corrosive gas.
- Once the package is opened, the products should be used within 3 days. Otherwise, they should be kept in a damp proof box with desiccating agent. Considering the tape life, we suggest our customers to use our products within a year(from production date)
- If opened more than 3 days in an atmosphere 5 °C ~35 °C, RH 60%, they should be treated at 60 °C ±5 °C for 15 hrs.
- Solder the lead pin under conditions of the absolute maximum rating chart and do not apply force on the solder pin after soldering.

### ◆ Guarantee Period and Scope

- Period  
One year after delivery to the desired place.
- Scope  
Replacement of products will be done if any problems lie in our company's products. However, we are not liable for your damage due to lack of caution.

### ◆ Others

- Any doubts concerning this specification should be discussed fully by both parties.