

1. Descriptions

The KP3528W8AC6I is a White LED consisting of small and thin form plastic leaded chip carrier (PLCC) 4-pin package, InGaN blue chip and phosphor.

2. Features

- ◆ Small Footprint Surface Mount Package (3.5 L × 2.8 W × 1.9 H [mm³])
- ◆ Typical Forward Voltage(V_F) : 3.2 V @ Forward Current(I_F)=60mA
- ◆ Operation Temperature from -40℃ to +85℃
- ◆ Soldering methods : IR reflow soldering
- ◆ Taping : 8mm conductive black carrier tape & antistatic clear cover tape

3. Applications

- ◆ Interior lighting
- ◆ General lighting
- ◆ Indoor and out door displays
- ◆ Architectural / Decorative lighting

The contents of this data sheet are subject to change without advance notice for the purpose of improvement.
When using this product, would you please refer to the latest specifications.

4. Outline Dimensions and Material Descriptions

◆ Outline Dimensions

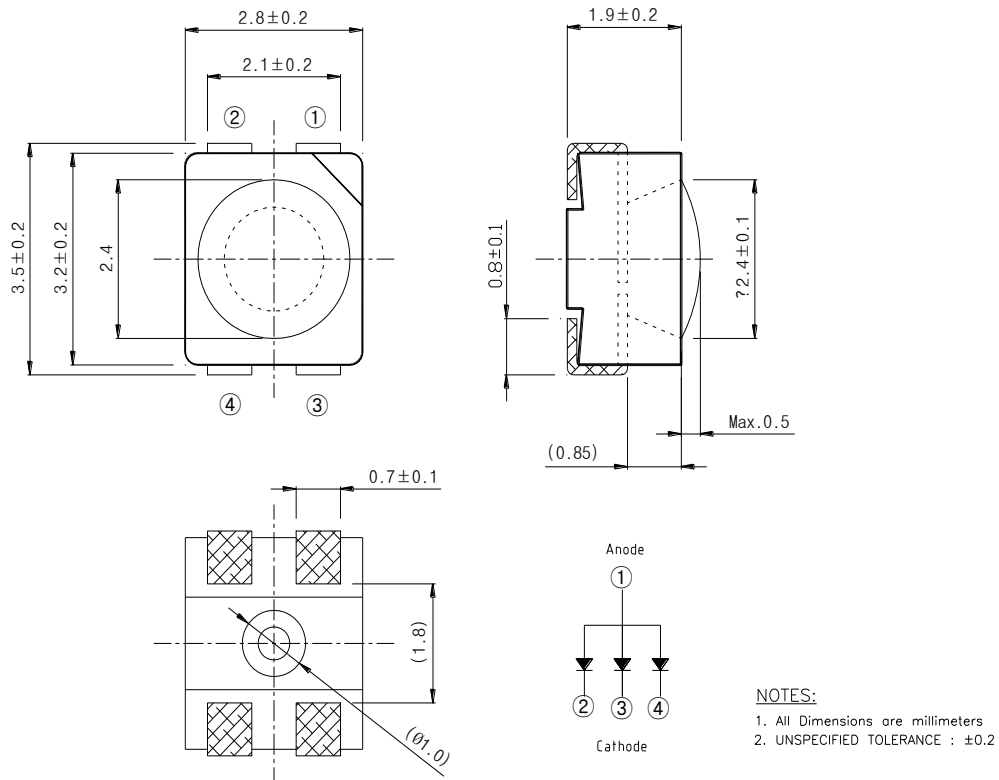

◆ Material Descriptions

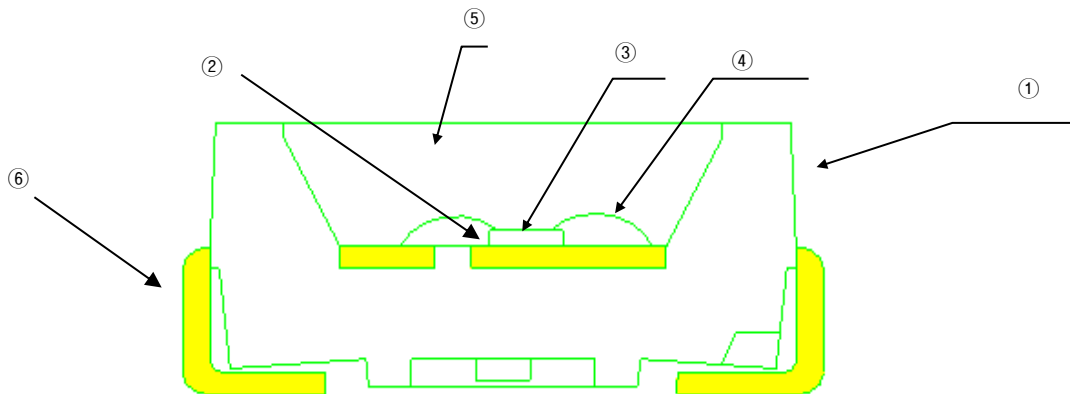

No.	Item	Material
①	Package	PPA
②	Die Adhesive	Clear Silicone
③	LED Chip	InGaN
④	Wire	Au
⑤	Encapsulant	Silicone + Phosphor
⑥	Lead	Fe Alloy

The contents of this data sheet are subject to change without advance notice for the purpose of improvement. When using this product, would you please refer to the latest specifications.

5. Absolute Maximums

Item	Symbol	Min.	Max.	Unit	Conditions
Forward Current	I_F	-	90	mA	
Peak Forward Current* ¹	I_{FP}	-	100	mA	per die
Power Dissipation	P_D	-	324	mW	
Reverse Voltage	V_R	-	5	V	per die
Operating Temperature	T_{OP}	-40	85	°C	
Storage Temperature	T_S	-40	100	°C	
Soldering Temperature* ²	T_{sol}	-	260	°C	

*1. IFP was measured at $T_w \leq 1$ msec of pulse width and $D \leq 1/10$ of duty ratio.

*2. Soldering time : 5 Sec

6. Electro-Optical Characteristics ($T_A = 25^\circ\text{C}$)

Item	Symbol	Min.	Typ.	Max.	Unit	Conditions
Forward voltage* ³	V_F	2.8	3.2	3.7	V	$I_F=20\text{mA}$ (per die)
Reverse current	I_R	-	-	10	μA	$V_R=5\text{V}$ (per die)
Luminous intensity* _{1,3}	I_V	5.0	6.0	8.0	cd	$I_F=60\text{mA}$
Color Temp.	CCT	-	10000	-	K	$I_F=60\text{mA}$
Color Rendering Index* ³	Ra	75	-	-	-	$I_F=60\text{mA}$
Half angle* ²	$2\theta_{1/2}$	-	120	-	deg	$I_F=60\text{mA}$

*1. The luminous intensity I_V was measured at the peak of the spatial pattern which may not be aligned with the mechanical axis of the LED package.

*2. $2\theta_{1/2}$ is the off-axis where the luminous intensity is 1/2 of the peak intensity.

*3. Measuring Tolerance

- $V_F : \pm 0.1 \text{ V}$, $I_V : \pm 10\%$, $R_a : \pm 3$, $X, Y : \pm 0.01$

The contents of this data sheet are subject to change without advance notice for the purpose of improvement. When using this product, would you please refer to the latest specifications.

7. Ranks

◆ IV, V_F, Color Rank @ I_F = 60 mA

Luminous Intensity Range[mcd]			
Luminuous Intensity [cd]	Forward Voltage [V]	Chromaticity	
P : 5.0 ~ 6.0	1 : 2.8 ~ 3.0	A1	A2
Q : 6.0 ~ 7.0	2 : 3.0 ~ 3.1	B1	B2
R : 7.0 ~ 8.0	3 : 3.1 ~ 3.2	C1	C2
X	4 : 3.2 ~ 3.3	X	X
	5 : 3.3 ~ 3.4		
	6 : 3.4 ~ 3.5		
	7 : 3.5 ~ 3.7		

◆ Color Coordinate Rank

A1		A2		B1		B2	
x	y	x	y	x	y	x	y
0.264	0.267	0.272	0.258	0.283	0.305	0.296	0.276
0.272	0.258	0.280	0.248	0.287	0.295	0.311	0.294
0.287	0.296	0.296	0.276	0.307	0.315	0.307	0.315
0.283	0.305	0.287	0.295	0.304	0.330	0.287	0.295
C1		C2					
x	y	x	y				
0.307	0.315	0.311	0.294				
0.330	0.339	0.330	0.318				
0.330	0.360	0.330	0.339				
0.304	0.330	0.307	0.315				

The contents of this data sheet are subject to change without advance notice for the purpose of improvement. When using this product, would you please refer to the latest specifications.

◆ The CIE(x, y) Chromaticity Diagram

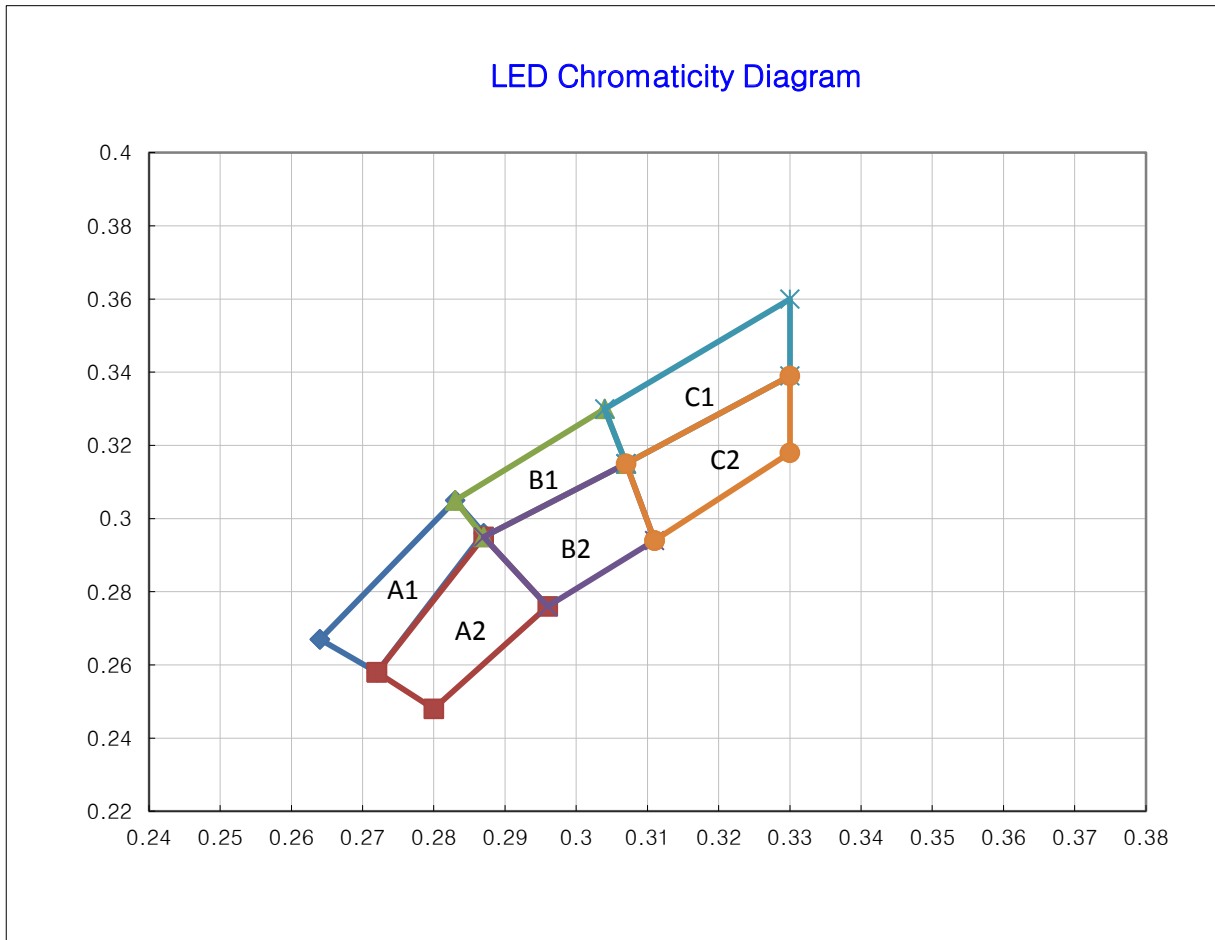

8. Part Numbering

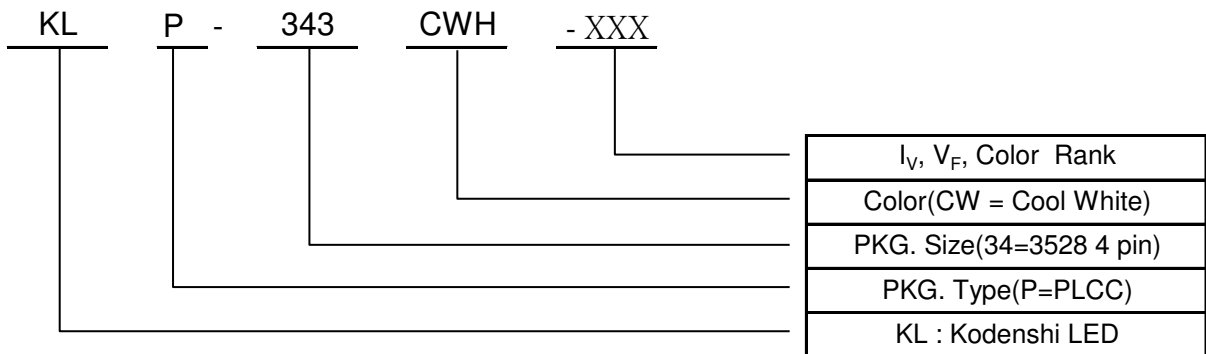

The contents of this data sheet are subject to change without advance notice for the purpose of improvement. When using this product, would you please refer to the latest specifications.

9. Characteristic Graphs

Forward current vs. Ambient temperature

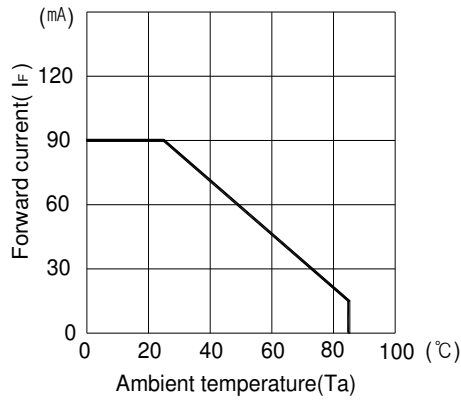

Radiant Intensity vs. Forward current

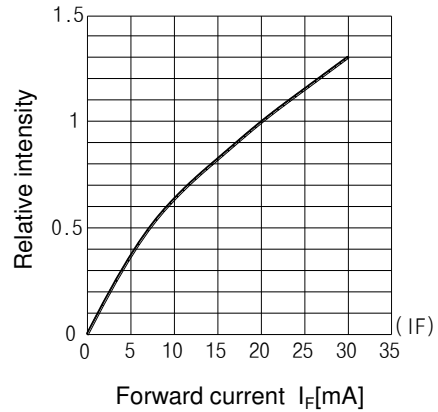

Relative radiant intensity vs. Ambient temperature

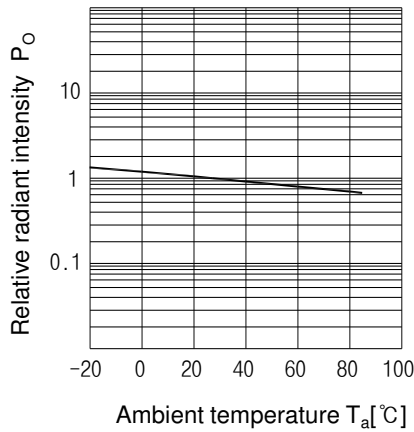

Relative intensity vs. Wavelength

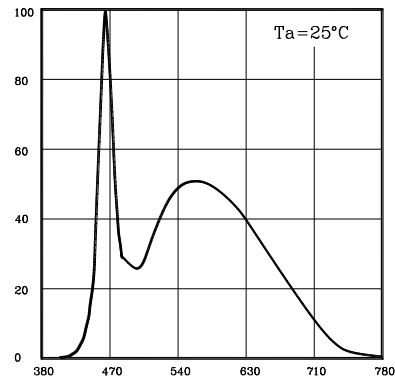

Forward current vs. Forward voltage

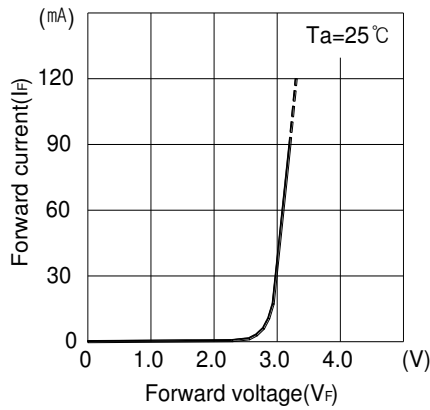

Radiant Pattern

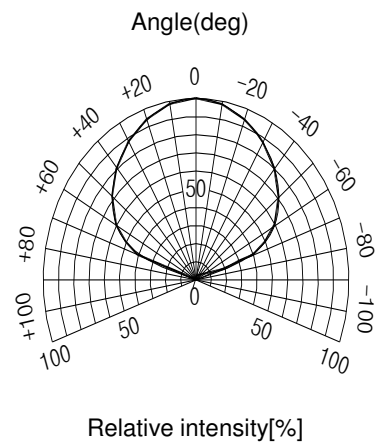

The contents of this data sheet are subject to change without advance notice for the purpose of improvement. When using this product, would you please refer to the latest specifications.