

1. Descriptions

The KP3528W06A2I is a White Color LED consisting of small and thin plastic leaded chip carrier (PLCC) 2-pin package, InGaN blue chip and phosphor.

2. Features

- ◆ Small Footprint Surface Mount Package (3.5 L × 2.8 W × 1.9 H [mm³])
- ◆ Typical Forward Voltage(V_F) : 3.2 V @ Forward Current(I_F)=20mA
- ◆ Operation Temperature from -40°C to +100°C
- ◆ Soldering methods : Reflow soldering
- ◆ JEDEC MSL level : 3
- ◆ Taping : 9mm conductive black carrier tape & antistatic clear cover tape

3. Applications

- ◆ Interior lighting
- ◆ General lighting
- ◆ Indoor and out door displays
- ◆ Architectural / Decorative lighting

The contents of this data sheet are subject to change without advance notice for the purpose of improvement.
When using this product, would you please refer to the latest specifications.

4. Outline Dimensions and Material Descriptions

◆ Outline Dimensions

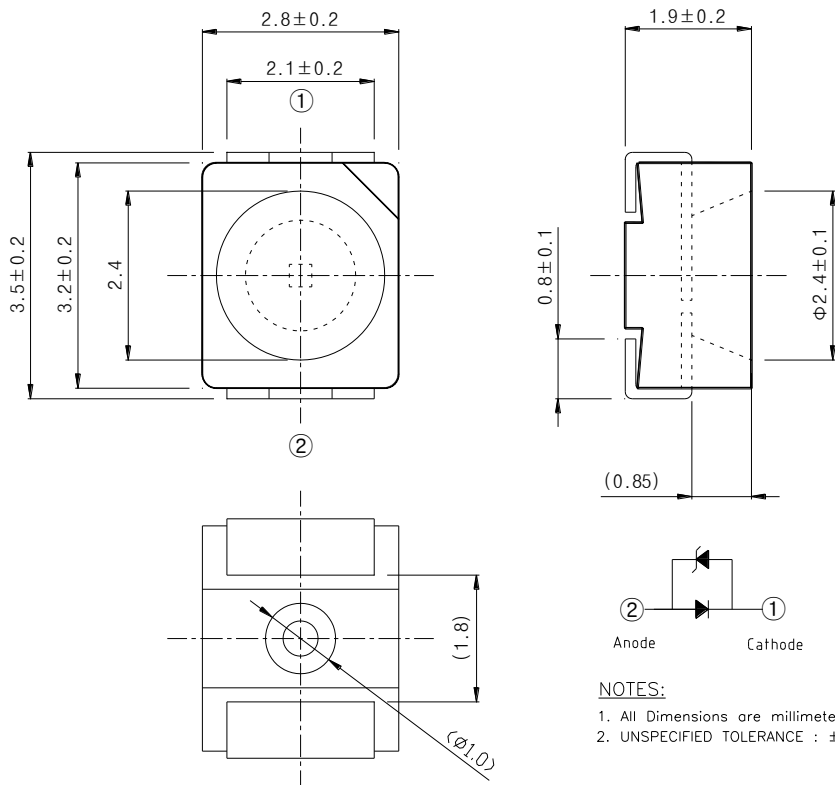

◆ Material Descriptions

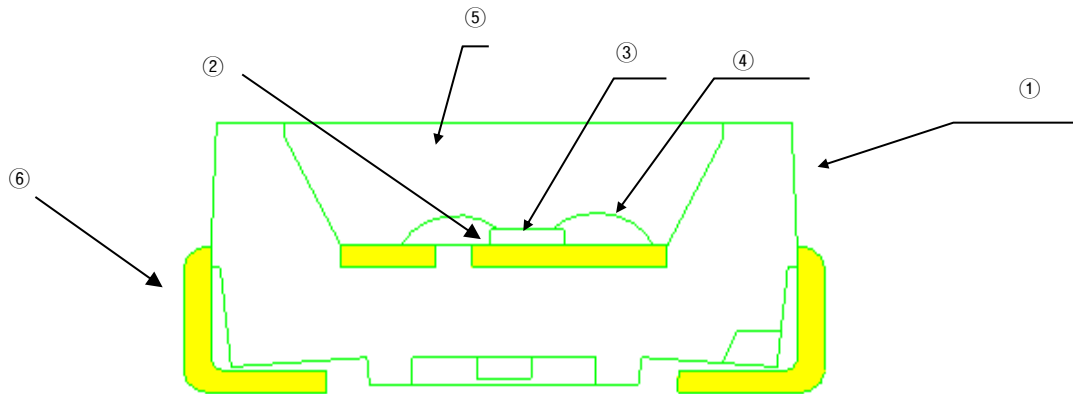

No.	Item	Material
①	Package	PPA
②	Die Adhesive	Clear Sillicone
③	LED Chip	InGaN
④	Wire	Au
⑤	Encapsulant	Clear Sillicone + Phsphor
⑥	Lead	Fe Alloy

The contents of this data sheet are subject to change without advance notice for the purpose of improvement. When using this product, would you please refer to the latest specifications.

5. Absolute Maximums

Item	Symbol	Min.	Max.	Unit	Conditions
Forward Current	I_F	-	30	mA	
Peak Forward Current* ¹	I_{FP}	-	100	mA	
Power Dissipation	P_D	-	114	mW	
Reverse Voltage	V_R	-	5	V	
Operating Temperature	T_{OP}	-40	100	°C	
Storage Temperature	T_S	-40	100	°C	
Soldering Temperature* ²	T_{sol}	-	260	°C	

*1. IFP was measured at $T_w \leq 1$ msec of pulse width and $D \leq 1/10$ of duty ratio.

*2. Soldering time : 5 Sec

6. Electro-Optical Characteristics ($T_A = 25^\circ\text{C}$)

Item	Symbol	Min.	Typ.	Max.	Unit	Conditions
Forward voltage* ³	V_F	2.8	3.2	3.7	V	$I_F=20\text{mA}$
Reverse Voltage	V_R	0.6	-	1.5	V	$I_R=5\text{mA}$
Luminous intensity* 1,3	I_V	2100	-	2700	mcd	$I_F=20\text{mA}$
Color Rendering Index* ³	Ra	55	-	-	-	$I_F=20\text{mA}$
Half angle* ²	$2\theta_{1/2}$	-	120	-	deg	$I_F=20\text{mA}$

*1. The luminous intensity I_V was measured at the peak of the spatial pattern which may not be aligned with the mechanical axis of the LED package.

*2. $2\theta_{1/2}$ is the off-axis where the luminous intensity is 1/2 of the peak intensity.

*3. Measuring Tolerance

- $V_F : \pm 0.1 \text{ V}$, $I_V : \pm 10\%$, Ra : ± 3 , X,Y : ± 0.01

The contents of this data sheet are subject to change without advance notice for the purpose of improvement. When using this product, would you please refer to the latest specifications.

7. Ranks

◆ I_V , V_F , Color Rank Table^{*1}

V _F , I _V , Color Rank @ IF = 20 mA		
Forward Voltage [V]	Luminous Intensity [mcd]	Chromaticity
1 : 2.8 ~ 3.7	R : 2100 ~ 2200	B
	S : 2200 ~ 2300	
	T : 2300 ~ 2400	
	U : 2400 ~ 2500	
	V : 2500 ~ 2600	
	W : 2600 ~ 2700	

*1. KP3528W0AA2I marked as 1SB21(V_F, I_V, Color Rank) has the I_V range 2.2~2.3cd, V_F rank 2.8~3.7V and Color range B area.

◆ Color Coordinate Rank

B21							
x	y						
0.2887	0.2720						
0.3100	0.3100						
0.3100	0.3350						
0.2887	0.2970						

The contents of this data sheet are subject to change without advance notice for the purpose of improvement. When using this product, would you please refer to the latest specifications.

◆ The CIE(x, y) Chromaticity Diagram

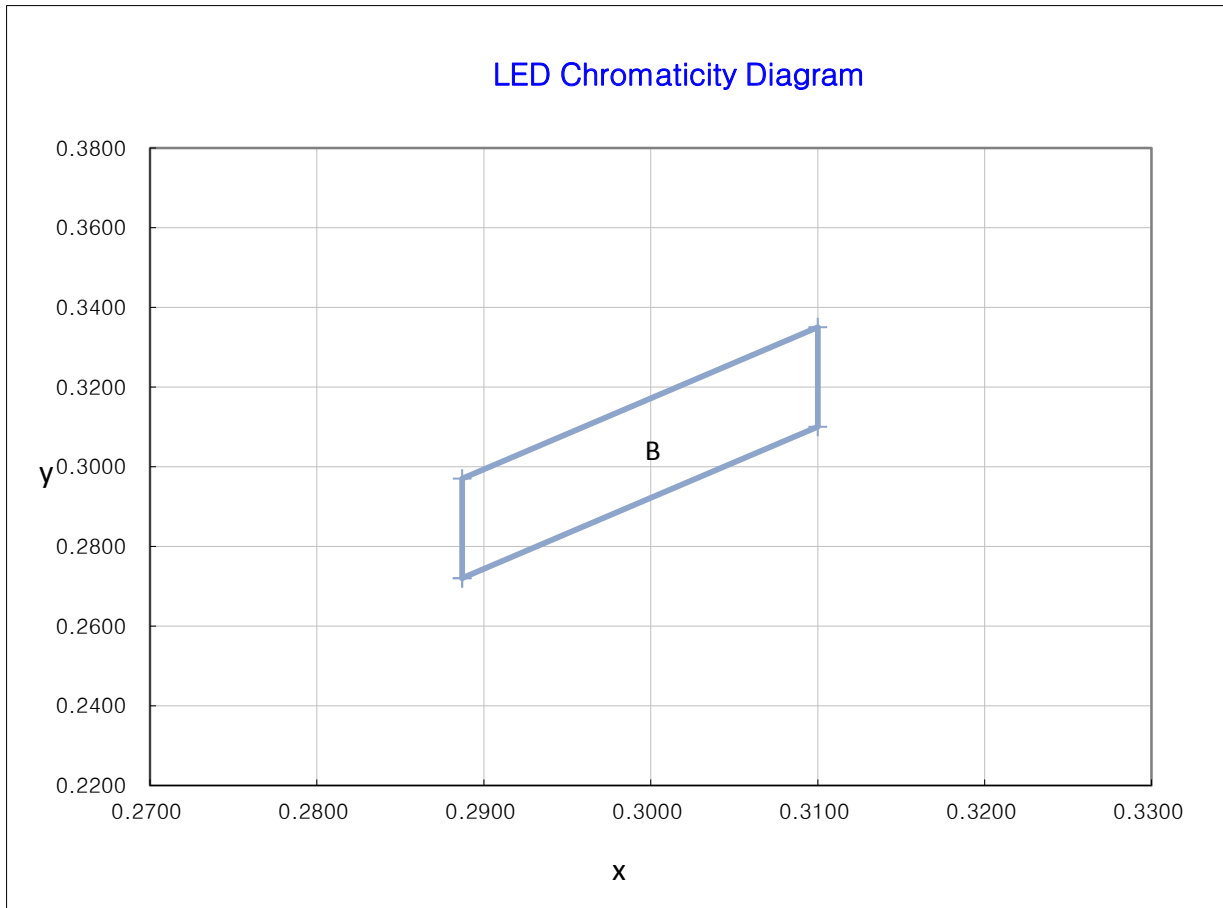

8. Part Numbering

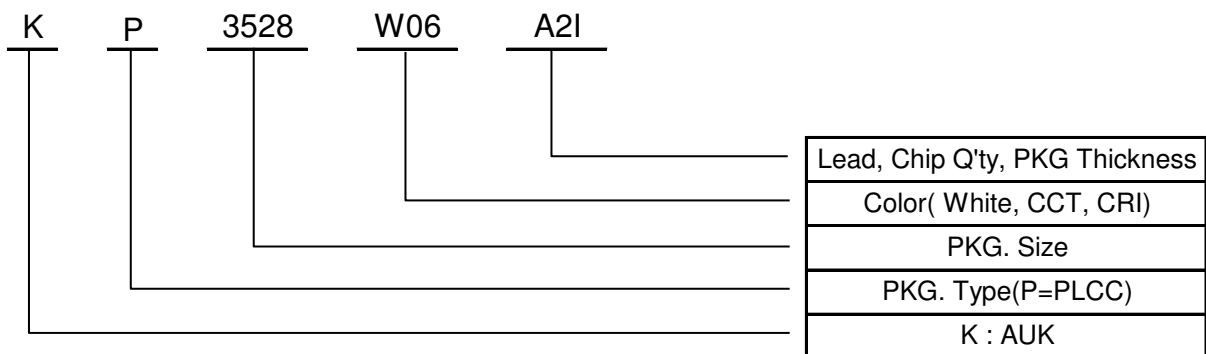

The contents of this data sheet are subject to change without advance notice for the purpose of improvement. When using this product, would you please refer to the latest specifications.

9. Characteristic Graphs

Forward current vs. Ambient temperature

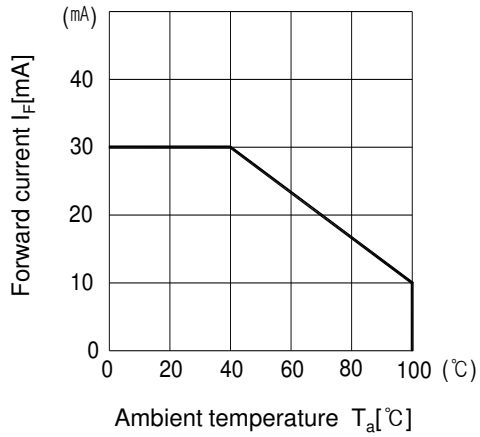

Luminous Intensity vs. Forward current

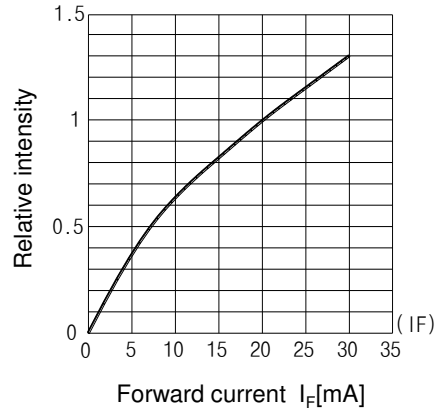

Relative luminous intensity vs. Ambient temperature

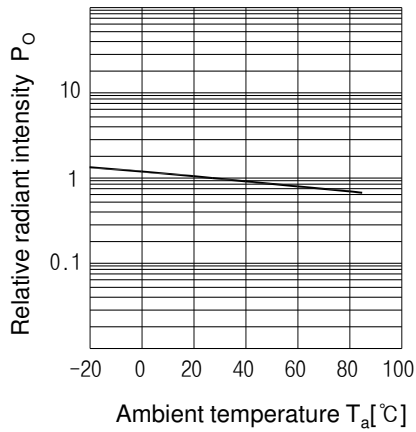

Relative intensity vs. Wavelength

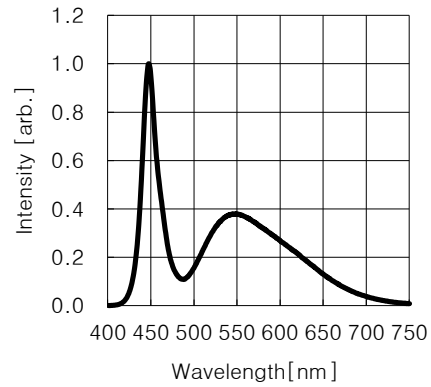

Forward current vs. Forward voltage

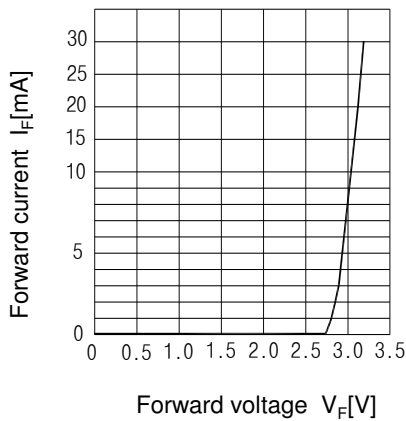

Radiant Pattern

