

## 1. Descriptions

The KP3528W00A2I is a White Color LED consisting of small and thin plastic leaded chip carrier (PLCC) 2-pin package, InGaN blue chip and phosphor.

## 2. Features

- ◆ Small Footprint Surface Mount Package ( 3.5 L × 2.8 W × 1.9 H [mm<sup>3</sup>])
- ◆ Typical Forward Voltage(V<sub>F</sub>) : 3.2 V @ Forward Current(I<sub>F</sub>)=20mA
- ◆ Operation Temperature from -40°C to +100°C
- ◆ Soldering methods : IR reflow soldering
- ◆ Taping : 8mm conductive black carrier tape & antistatic clear cover tape

## 3. Applications

- ◆ Interior lighting
- ◆ General lighting
- ◆ Indoor and out door displays
- ◆ Architectural / Decorative lighting

---

The contents of this data sheet are subject to change without advance notice for the purpose of improvement.  
When using this product, would you please refer to the latest specifications.

---

**4. Outline Dimensions and Material Descriptions**

◆ Outline Dimensions

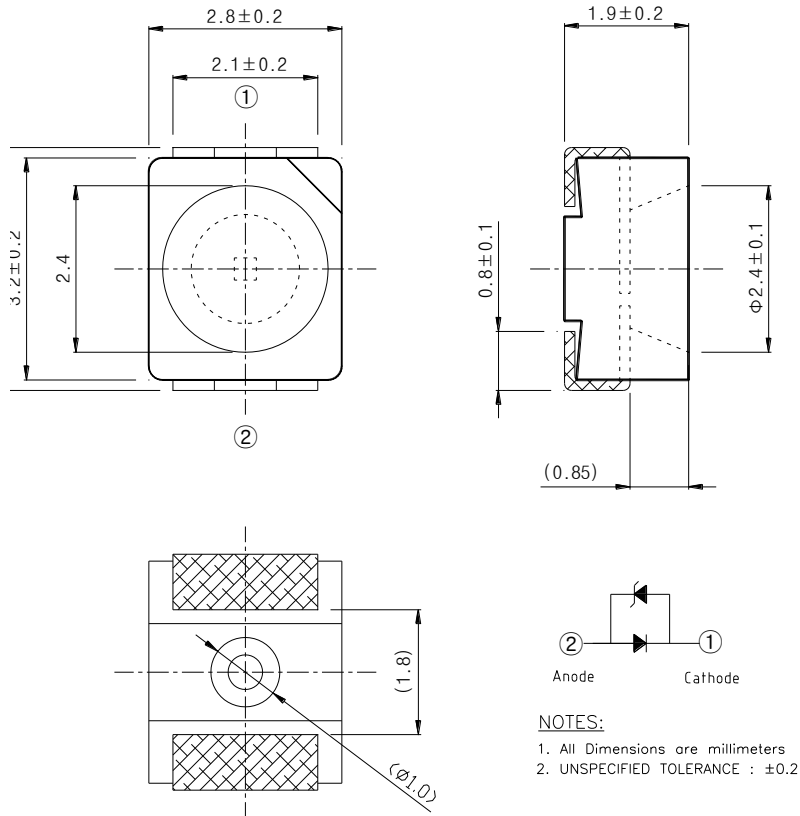

◆ Material Descriptions

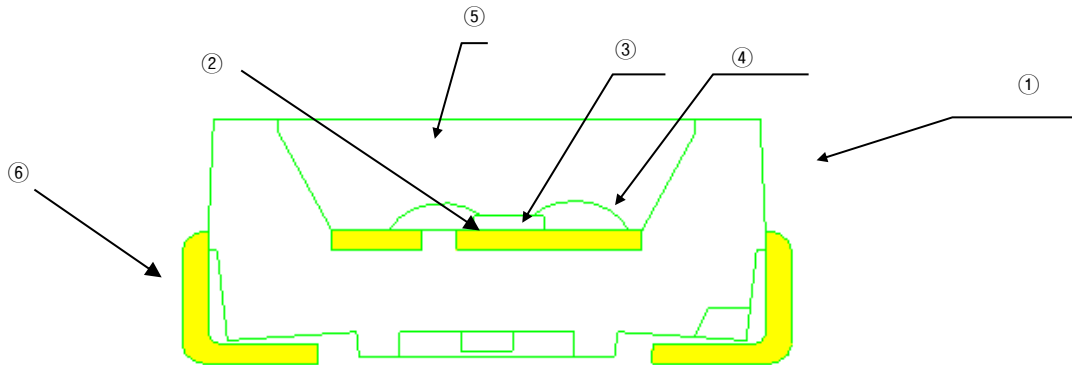

No.	Item	Material
①	Package	PPA
②	Die Adhesive	Clear Silicone
③	LED Chip	InGaN
④	Wire	Au
⑤	Encapsulant	Clear Silicone + Phosphor
⑥	Lead	Fe Alloy

The contents of this data sheet are subject to change without advance notice for the purpose of improvement. When using this product, would you please refer to the latest specifications.

## 5. Absolute Maximums

Item	Symbol	Min.	Max.	Unit	Conditions
Forward Current	$I_F$	-	30	mA	
Peak Forward Current* <sup>1</sup>	$I_{FP}$	-	100	mA	
Power Dissipation	$P_D$	-	111	mW	
Reverse Voltage	$V_R$	-	5	V	
Operating Temperature	$T_{OP}$	-40	100	°C	
Storage Temperature	$T_S$	-40	100	°C	
Soldering Temperature* <sup>2</sup>	$T_{sol}$	-	260	°C	

\*1. IFP was measured at  $T_w \leq 1$  msec of pulse width and  $D \leq 1/10$  of duty ratio.

\*2. Soldering time : 5 Sec

## 6. Electro-Optical Characteristics ( $T_A = 25^\circ\text{C}$ )

Item	Symbol	Min.	Typ.	Max.	Unit	Conditions
Forward voltage* <sup>3</sup>	$V_F$	2.9	3.2	3.5	V	$I_F=20\text{mA}$
Reverse voltage	$V_R$	0.5	-	1.5	V	$I_R=5\text{mA}$
Luminous intensity* <sub>1,3</sub>	$I_V$	800	1000	1200	mcd	$I_F=20\text{mA}$
Chromaticity coordiante* <sup>3</sup>	x	0.245	0.26	0.280	-	$I_F=20\text{mA}$
	y	0.225	0.24	0.255	-	$I_F=20\text{mA}$
Half angle* <sup>2</sup>	$2\theta_{1/2}$	-	120	-	deg	$I_F=20\text{mA}$

\*1. The luminous intensity  $I_V$  was measured at the peak of the spatial pattern which may not be aligned with the mechanical axis of the LED package.

\*2.  $2\theta_{1/2}$  is the off-axis where the luminous intensity is 1/2 of the peak intensity.

\*3. Measuring Tolerance

-  $V_F : \pm 0.1$  V,  $I_V : \pm 10\%$ ,  $R_a : \pm 3$ , X,Y :  $\pm 0.01$

The contents of this data sheet are subject to change without advance notice for the purpose of improvement.  
When using this product, would you please refer to the latest specifications.

**7. Ranks**

◆  $I_V$ ,  $V_F$ , Color Rank Table<sup>\*1</sup>

V <sub>F</sub> , I <sub>V</sub> , Color Rank @ IF = 20 mA		
Forward Voltage [V]	Luminuous Intensity [mcd]	Chromaticity
1 : 2.9 ~ 3.2	P : 800 ~ 1000	A1
2 : 3.2 ~ 3.5	Q : 1000 ~ 1200	X

\*1. KP3528W00A2I marked as 2QA1(V<sub>F</sub>, I<sub>V</sub>, Color Rank) has the I<sub>V</sub> range 1.0~1.2cd, VF rank 3.2~3.4V and Color range b area.

◆ Color Coordinate Rank

A1							
x	y						
0.2525	0.2250						
0.2650	0.2250						
0.2800	0.2550						
0.2675	0.2550						

The contents of this data sheet are subject to change without advance notice for the purpose of improvement. When using this product, would you please refer to the latest specifications.

◆ The CIE(x, y) Chromaticity Diagram

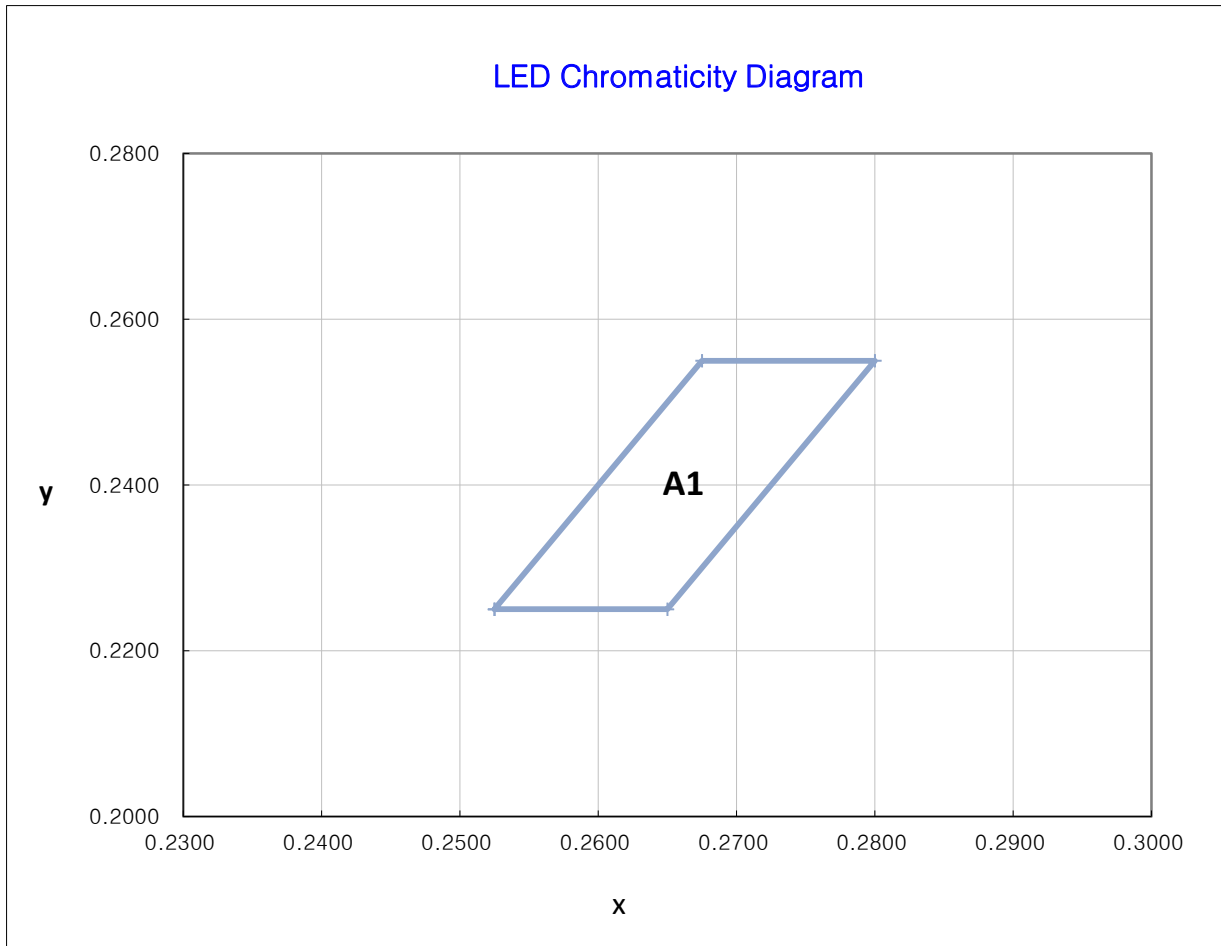

**8. Part Numbering**

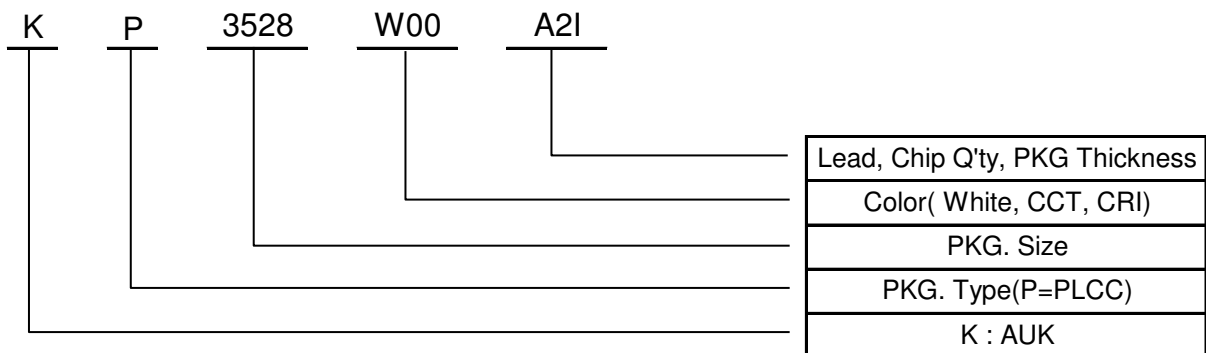

The contents of this data sheet are subject to change without advance notice for the purpose of improvement. When using this product, would you please refer to the latest specifications.

**9. Characteristic Graphs**

**Forward current vs. Ambient temperature**

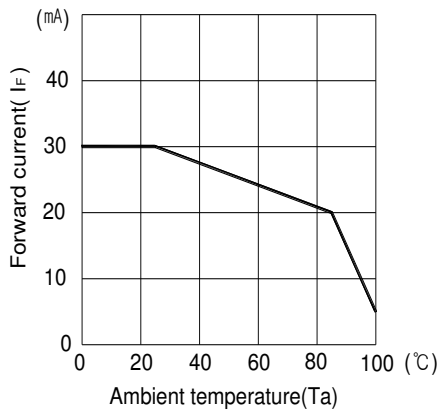

**Luminous Intensity vs. Forward current**

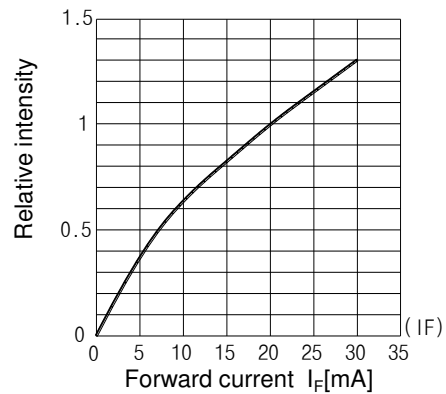

**Relative luminous intensity vs. Ambient temperature**

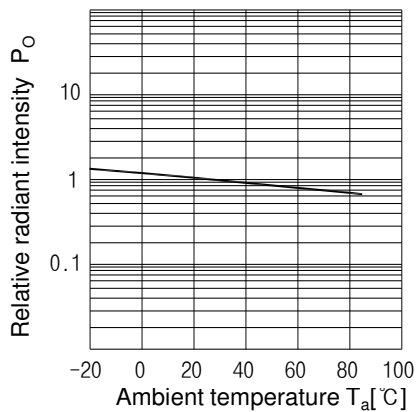

**Relative intensity vs. Wavelength**

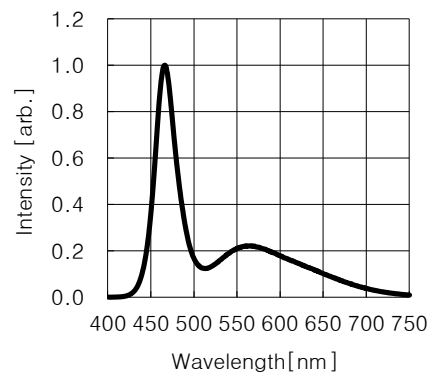

**Forward current vs. Forward voltage**

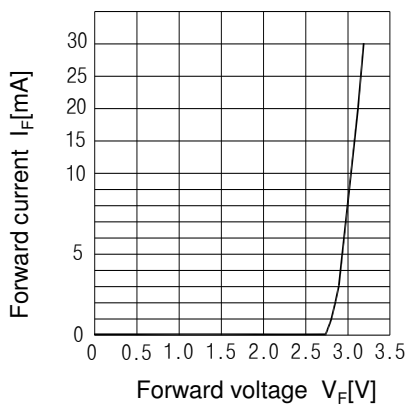

**Radiant Pattern**

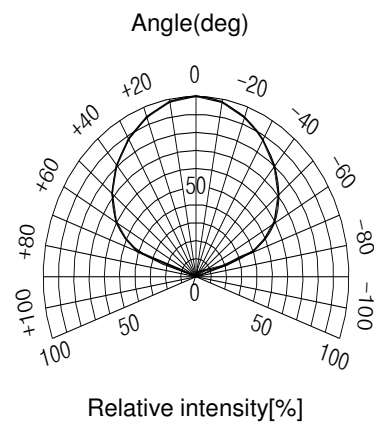

The contents of this data sheet are subject to change without advance notice for the purpose of improvement. When using this product, would you please refer to the latest specifications.