

## 1. Descriptions

The KP3528F00C8I is a Red, Green, Blue Multi Color LED consisting of small and thin plastic leaded chip carrier (PLCC) 4-pin package.

## 2. Features

- ◆ Small Footprint Surface Mount Package ( 3.5 L × 2.8 W × 1.9 H [mm<sup>3</sup>])
- ◆ 4 Pin R, G, B separate type LED
- ◆ Operation Temperature from -30°C to +85°C
- ◆ Soldering methods : IR reflow soldering
- ◆ Taping : 8mm conductive black carrier tape & antistatic clear cover tape

## 3. Applications

- ◆ Interior lighting
- ◆ General lighting
- ◆ Indoor and out door displays
- ◆ Architectural / Decorative lighting

---

The contents of this data sheet are subject to change without advance notice for the purpose of improvement.  
When using this product, would you please refer to the latest specifications.

---

**4. Outline Dimensions and Material Descriptions**

◆ Outline Dimensions

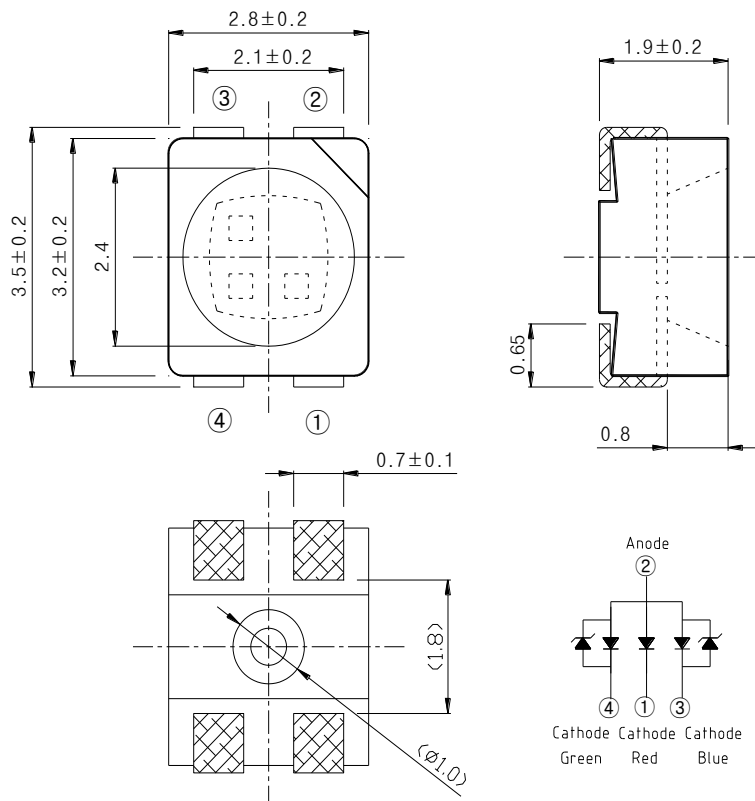

**NOTES:**

1. All Dimensions are millimeters
2. UNSPECIFIED TOLERANCE :  $\pm 0.2$

◆ Material Descriptions

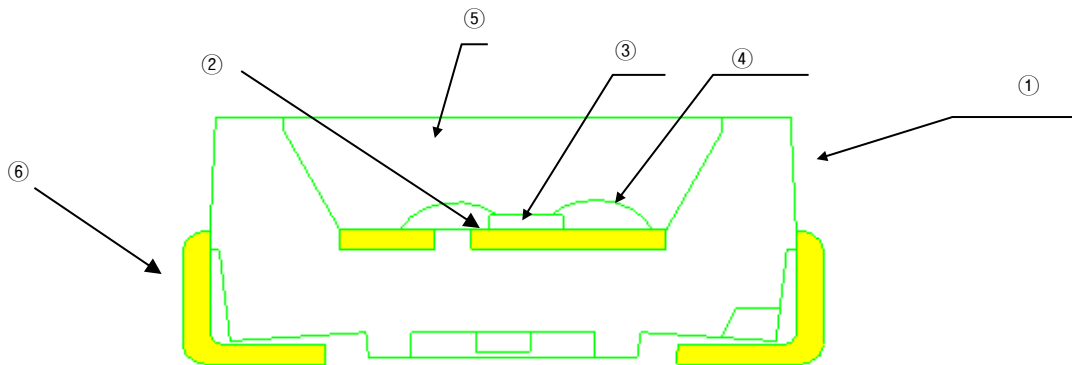

No.	Item	Material
①	Package	PPA
②	Die Adhesive	Clear Silicone
③	LED Chip	InGaN, AlGaInP
④	Wire	Au
⑤	Encapsulant	Clear Silicone
⑥	Lead	Fe Alloy

The contents of this data sheet are subject to change without advance notice for the purpose of improvement. When using this product, would you please refer to the latest specifications.

## 5. Absolute Maximums

Item	Symbol	Value			Unit	Remarks
		Red	Green	Blue		
Forward Current	$I_F$	30	30	30	mA	
Peak Forward Current* <sup>1</sup>	$I_{FP}$	100	100	100	mA	
Power Dissipation	$P_D$	75	108	108	mW	
Reverse Voltage	$V_R$	5			V	
Operating Temperature	$T_{OP}$	-30 ~ +85			°C	
Storage Temperature	$T_S$	-40 ~ +100			°C	
Soldering Temperature* <sup>2</sup>	$T_{sol}$	260			°C	

\*1. IFP was measured at  $T_w \leq 1$  msec of pulse width and  $D \leq 1/10$  of duty ratio.

\*2. Soldering time : 5 Sec

6. Electro-Optical Characteristics ( $T_A = 25^\circ\text{C}$ )

Item		Symbol	Min.	Typ.	Max.	Unit	Conditions
Forward voltage* <sup>3</sup>	R	$V_F$	1.7	2.0	2.5	V	$I_F=20\text{mA}$
	G		2.7	3	3.6		
	B		2.7	3	3.6		
Reverse current	R	$I_R$	-	-	5	uA	$V_R=5\text{V}$
	G		-	-	5		
	B		-	-	5		
Luminous intensity* <sup>1,3</sup>	R,G,B	$I_V$	700	1000	1500	mcd	Red_ $I_F=25\text{mA}$ , Green_ $I_F=11\text{mA}$ , Blue_ $I_F=7\text{mA}$
Chromaticity coordiante* <sup>3</sup>	R,G,B	x	0.250	-	0.350	-	Red_ $I_F=25\text{mA}$ , Green_ $I_F=11\text{mA}$ , Blue_ $I_F=7\text{mA}$
		y	0.250	-	0.350	-	
Half angle* <sup>2</sup>	R,G,B	$2\theta_{1/2}$	-	120	-	deg	$I_F=20\text{mA}$

\*1. The luminous intensity  $I_V$  was measured at the peak of the spatial pattern which may not be aligned with the mechanical axis of the LED package.

\*2.  $2\theta_{1/2}$  is the off-axis where the luminous intensity is 1/2 of the peak intensity.

\*3. Measuring Tolerance

-  $V_F : \pm 0.1 \text{ V}$ ,  $I_V : \pm 10\%$ ,  $x, y : \pm 0.01$

The contents of this data sheet are subject to change without advance notice for the purpose of improvement. When using this product, would you please refer to the latest specifications.

**7. Ranks**

◆  $I_v$ , Color Rank Table \*1

$I_v$ , Color Rank @ Red_IF = 25 mA, Green_IF = 11 mA, Blue_IF = 7 mA			
Luminuous Intensity [mcd]	Chromaticity		-
T : 700 ~ 1000	A1	E1	-
U : 1000 ~ 1200	B1	F1	-
V : 1200 ~ 1500	C1	G1	-
-	D1	H1	-

\*1. KP3528F00E6D marked as TA1( $I_v$ , Color Rank) has the  $I_v$  range 0.7~1.0cd and Color range A1 area.

◆ Color Coordinate Rank

A1		B1		C1		D1	
x	y	x	y	x	y	x	y
0.2600	0.3500	0.2575	0.3250	0.2550	0.3000	0.2525	0.2750
0.2575	0.3250	0.2550	0.3000	0.2525	0.2750	0.2500	0.2500
0.3025	0.3250	0.3000	0.3000	0.2975	0.2750	0.2950	0.2500
0.3050	0.3500	0.3025	0.3250	0.3000	0.3000	0.2975	0.2750
E1		F1		G1		H1	
x	y	x	y	x	y	x	y
0.2525	0.2250	0.3025	0.3250	0.3000	0.3000	0.2975	0.2750
0.2650	0.2250	0.3000	0.3000	0.2975	0.2750	0.2950	0.2500
0.2800	0.2550	0.3450	0.3000	0.3425	0.2750	0.3400	0.2500
0.2675	0.2550	0.3475	0.3250	0.3450	0.3000	0.3425	0.2750

The contents of this data sheet are subject to change without advance notice for the purpose of improvement. When using this product, would you please refer to the latest specifications.

◆ The CIE(x, y) Chromaticity Diagram

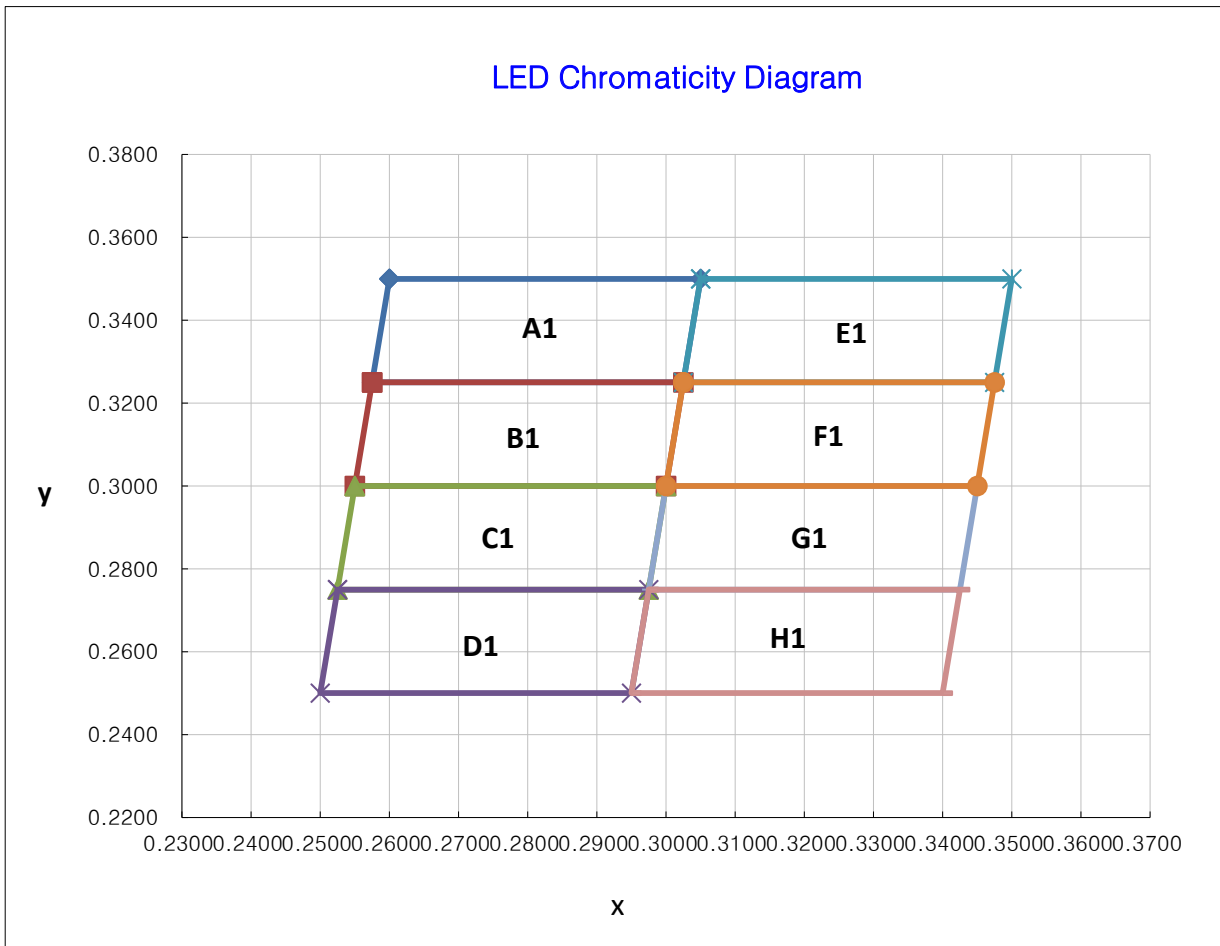

**8. Part Numbering**

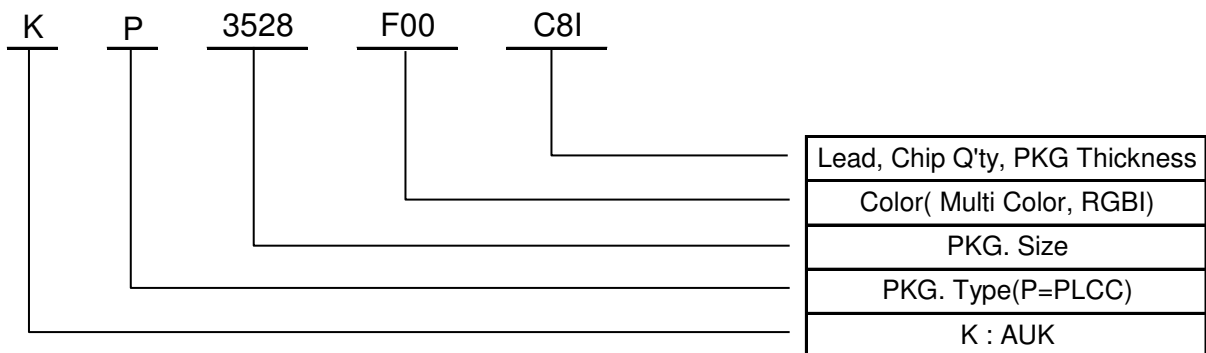

The contents of this data sheet are subject to change without advance notice for the purpose of improvement. When using this product, would you please refer to the latest specifications.

**9. Characteristic Graphs**

**Forward current vs. Ambient temperature**

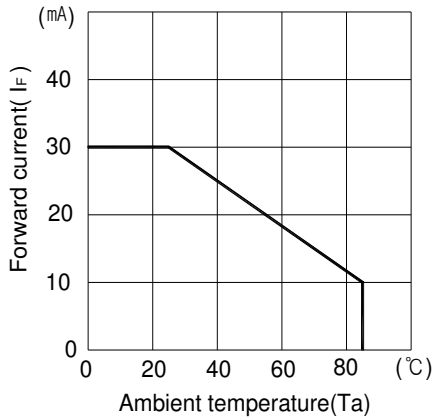

**Luminous Intensity vs. Forward current**

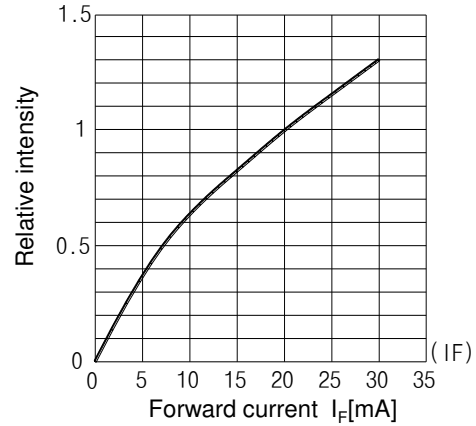

**Relative luminous intensity vs. Ambient temperature**

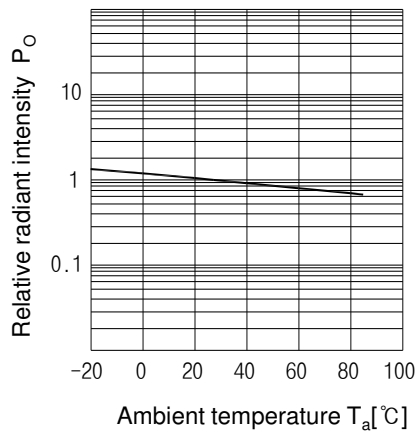

**Relative intensity vs. Wavelength**

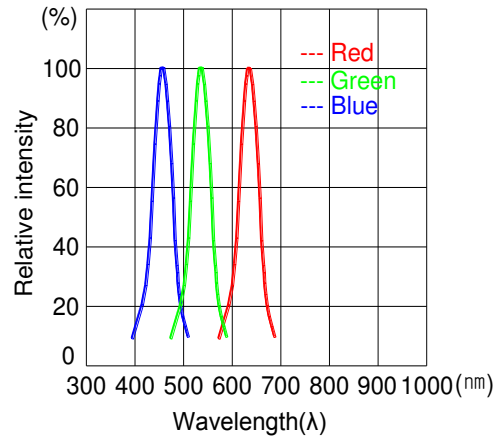

**Forward current vs. Forward voltage**

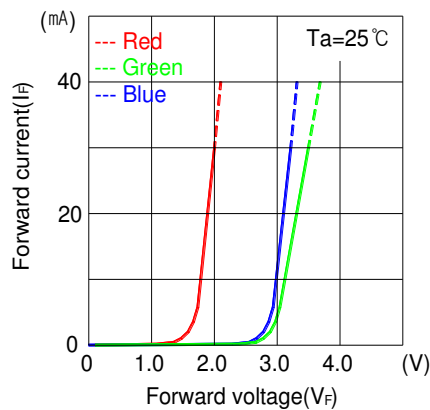

**Radiant Pattern**

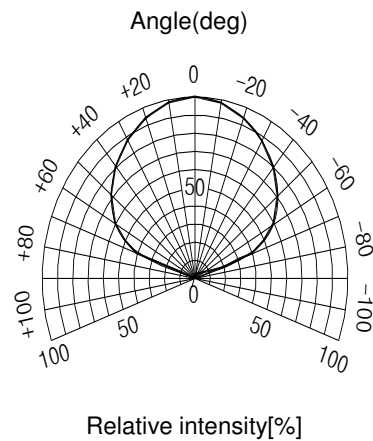

The contents of this data sheet are subject to change without advance notice for the purpose of improvement. When using this product, would you please refer to the latest specifications.