

Photo Interrupter

KIT8002A

Description

The KIT8002A is a high performance transmissive type photointerrupter, combines high-output GaAs IRED with high sensitive phototransistor,

Features

- PWB direct mount type
- With the installation positioning boss
- 8.0mm Gap

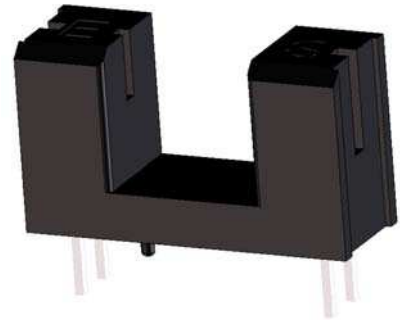

Applications

- Printers
- Copiers
- Fax

Absolute Maximum Ratings (T_{amb}=25°C, Unless otherwise specified)

Item		Symbol	Ratings	Unit
Input	Power Dissipation	P _D	100	mW
	Forward Current	I _F	60	mA
	Reverse Voltage	V _R	5	V
	Pulse Forward Current *1	I _{FP}	1	A
Output	Collector Dissipation	P _C	100	mW
	Collector Current	I _C	40	mA
	Collector-Emitter Voltage	V _{CEO}	30	V
	Emitter-Collector Voltage	V _{ECO}	5	V
Operating Temperature *2		T _{opr}	-25 ~ +85	°C
Storage Temperature *2		T _{stg}	-40 ~ +85	°C

* 1. Pulse width (tw) ≤ 100 μs, Period (T) = 10msec.

* 2. No icebond or dew.

The contents of this data sheet are subject to change without advance notice for the purpose of improvement. When using this product, would you please refer to the latest specifications.

Electrical Characteristics (Tamb=25°C, Unless otherwise specified)

Operation is specified over the entire operating temperature / humidity range unless otherwise specified.

Operating Temperature	Topr	+5 to +45	°C
Operating Humidity (over Topr Range)	Hopr	5 ~ 95	%RH

Parameter		Symbol	Conditions	Min.	Typ.	Max.	Unit
Input	Forward Voltage	V_F	$I_F=20\text{mA}$	-	1.2	1.4	V
	Wavelength of Emission	λ_p	$I_F=20\text{mA}$	-	940	-	nm
	Reverse Current	I_R	$V_R=3\text{V}$	-	-	10	μA
Output	Dark Current	I_{CEO}	$V_{CE}=5.0\text{V}$, $I_F=0\text{ mA}$ $E=0\text{ lux}$	-	-	1	μA
Transfer Characteristics	Collector Current	I_C	$V_{CC}=5.0\text{V}$, $I_F=20\text{mA}$	0.5	-	10	mA
	Collector - Emitter Saturation Voltage	$V_{CE(sat)}$	$I_C=0.5\text{ mA}$, $I_F=20\text{ mA}$	-	-	0.4	V

See Figure 1. for Test circuit

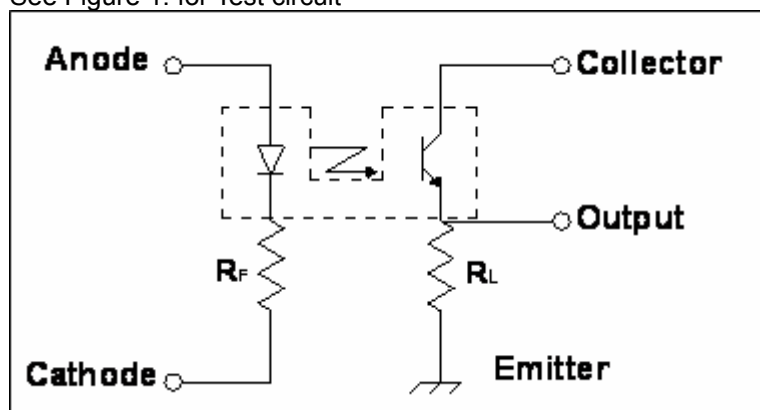

\

The contents of this data sheet are subject to change without advance notice for the purpose of improvement. When using this product, would you please refer to the latest specifications.

Switching as a Function of Position

1. If the motion of the interrupter flag is vertical(perpendicular to the horizontal aperture slot) then the output must switch between approximately -0.25 to +0.25mm with respect to the optical axis.
2. If the motion of the interrupter flag is horizontal(parallel to the horizontal aperture slot) then the output must switch between approximately -0.50 to +0.50mm with respect to the optical axis.

Packaging

1. The part package contain the following information:
 - Symbol
 - Date Code
 - Lot Code
 - The words "RoHS Compliant"

Cautions in Usage

1. Store and use where there is no exterior force that will cause change in shape.
2. Store and use where there is no Hydrogen Sulfide gas, or any other corrosive gas.
3. The bending or cutting of the lead should be done at room temperature, no force being applied on the package.
4. Solder the lead pin under conditions of the absolute maximum rating chart, and do not apply force on the lead pin after soldering.

Guarantee Period and Scope

1. Period
One year after delivery to the desired place.
2. Scope
Replacement of products will be done, if any problems lie in our company's products.
However, we are not liable for your damage by lack of caution.

Others

Any doubts concerning this specification should be discussed fully by both parties.

The contents of this data sheet are subject to change without advance notice for the purpose of improvement.
When using this product, would you please refer to the latest specifications.

Characteristics

Forward Current Vs. Collector Dissipation Temperature Rating

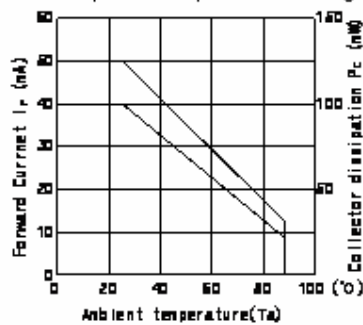

Forward current Vs. Forward voltage

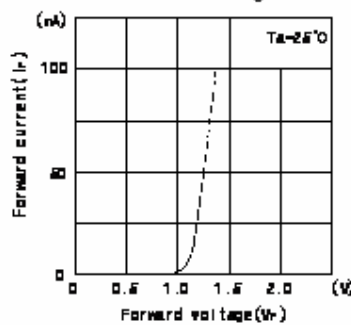

Collector Current Vs. Forward Current

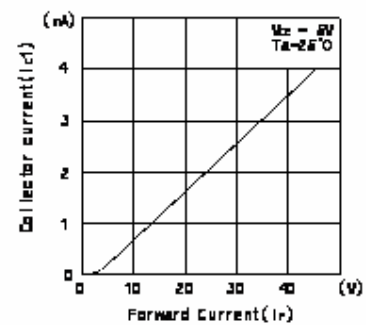

Collector Current Vs. Collector-Emitter Voltage

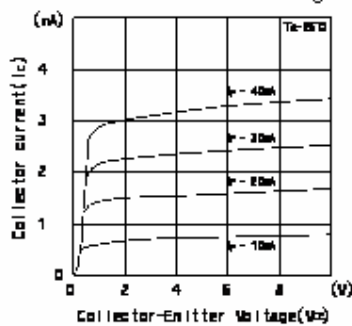

Relative Collector Current Vs. Ambient temperature

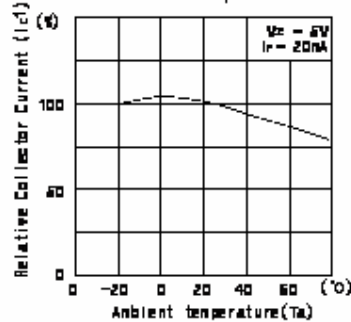

Collector Current Vs. Ambient temperature

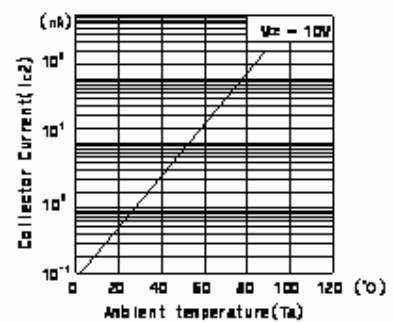

Switching time Vs. Load resistance

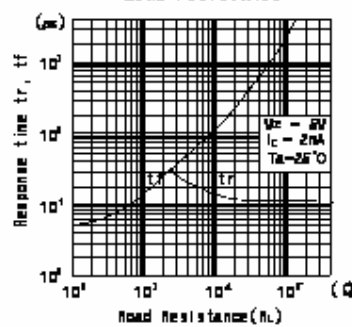

Relative Collector Current Vs. Moving distance

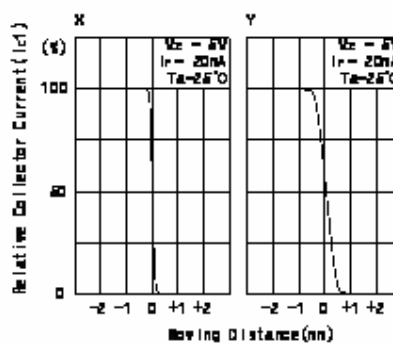

Switching time measurement circuit

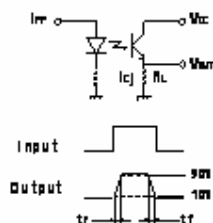

Method of measuring position detection characteristic

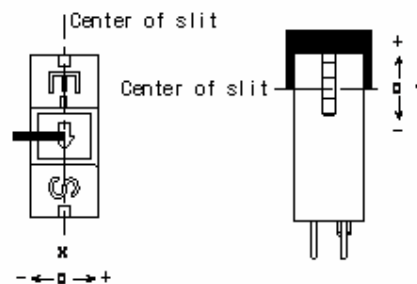

The contents of this data sheet are subject to change without advance notice for the purpose of improvement. When using this product, would you please refer to the latest specifications.

Package Outline Dimensions

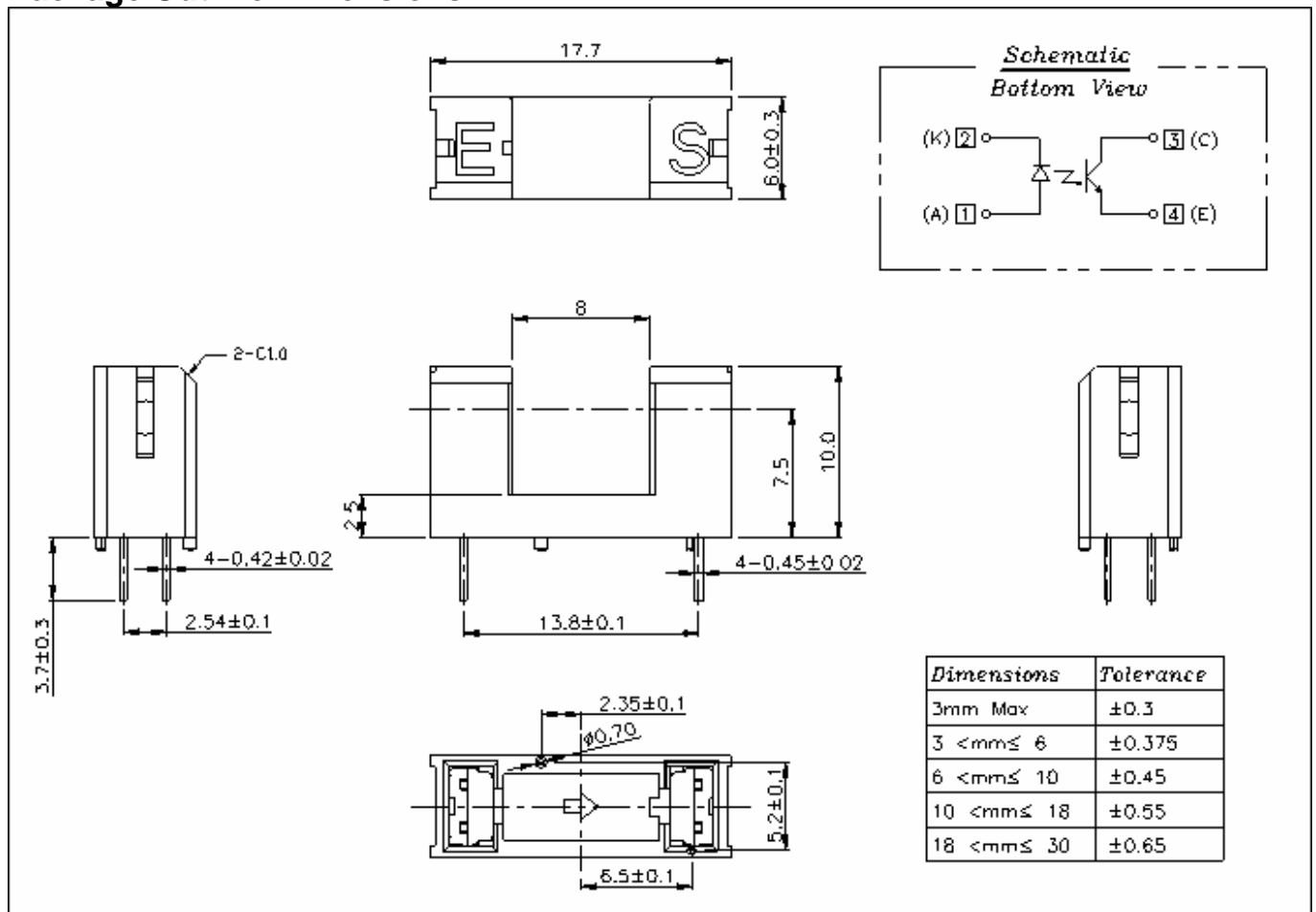

The contents of this data sheet are subject to change without advance notice for the purpose of improvement. When using this product, would you please refer to the latest specifications.