

Photo Interrupter

KIT1018S

Description

The KIT1018S photo-interrupter high-performance standard type, combines high-output GaAs IRED with high sensitivity phototransistor.



Features

- PWB direct mount type.
- 1.1mm gap.
- Compact.
- Lead Free, RoHS and Halogen Free Compliant.

Applications

- Cameras.
- Copiers.
- Printers.
- DVD Player.

Absolute Maximum Ratings (T_a=25°C, Unless otherwise specified)

Characteristic		Symbol	Ratings	Unit
Input LED	Power Dissipation	P _D	75	mW
	Forward Current	I _F	50	mA
	Reverse Voltage	V _R	6	V
	Pulse Forward Current *1	I _{FP}	0.5	A
Output Detector	Collector Dissipation	P _C	75	mW
	Collector Current	I _C	20	mA
	C-E Voltage	V _{CEO}	30	V
	E-C Voltage	V _{ECO}	6	V
Operating Temperature *2		Topr.	-25 ~ +85	°C
Storage Temperature *2		Tstg.	-40 ~ +100	°C
Soldering Temperature *3		Tsol.	260	°C

*1 : Pulse width $t_w \leq 100 \mu s$ period $T = 10 ms$

*2 : No icebound or dew

*3 : The soldering should be 0.3mm or more away from bottom of the case t=within 3sec

The contents of this data sheet are subject to change without advance notice for the purpose of improvement.
When using this product, would you please refer to the latest specifications.

Electrical Characteristics (T_a=25°C)

Characteristic		Symbol	Min.	Typ.	Max.	Unit	Condition
Input LED	Forward Voltage	V _F	-	1.2	1.4	V	I _F =20 mA
	Reverse Current	I _R	-	-	10	μA	V _R =5V
	Peak Wavelength	λ _P	-	940	-	nm	I _F =20 mA
Output Detector	Dark Current	I _{CEO}	-	1	100	nA	V _{CE} =10V, 0Ix
	Peak Wavelength	λ _P	-	880	-	nm	-
Transmission Characteristics	Light Current (Collector Current)	I _C	0.10	-	0.45	mA	I _F =5 mA, V _{CE} =5V Non shading
	Leakage Current	I _{CEO} D	-	0.5	10	μA	I _F =5 mA, V _{CE} =5V Shading
	C-E Saturation Voltage	V _{CE(sat)}	-	0.15	0.4	V	I _F =10 mA, I _C =0.03 mA
Response Time	Rise Time	t _r	-	10	-	μs	V _{CC} =5V, I _C =1 mA R _L =100Ω
	Fall Time	t _f	-	10	-	μs	

- Circuit for measuring response time

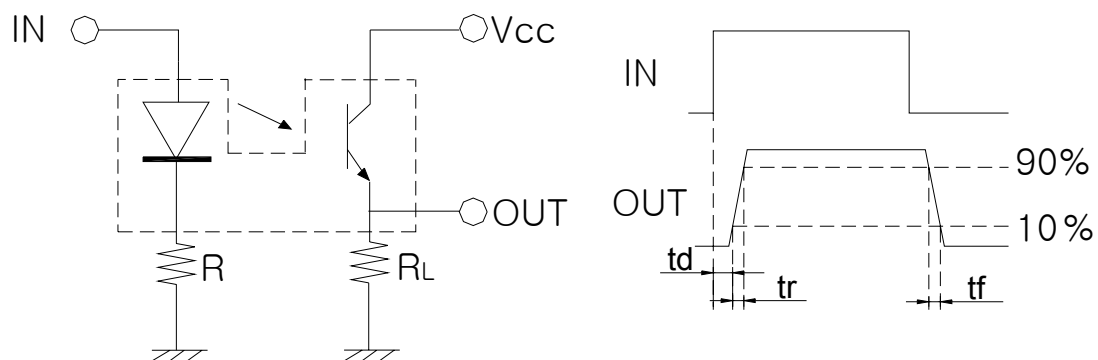

The contents of this data sheet are subject to change without advance notice for the purpose of improvement. When using this product, would you please refer to the latest specifications.

Electrical and optical characteristic curves

Collector power dissipation Vs. Ambient temperature

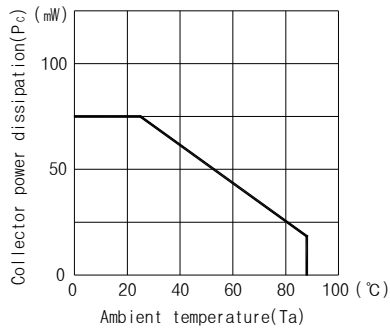

Forward current Vs. Forward voltage

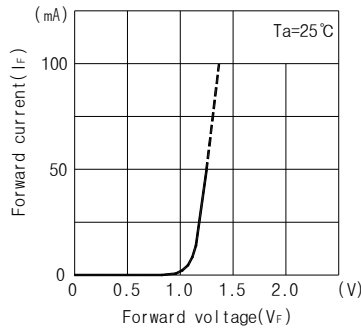

Collector Current Vs. Forward Current

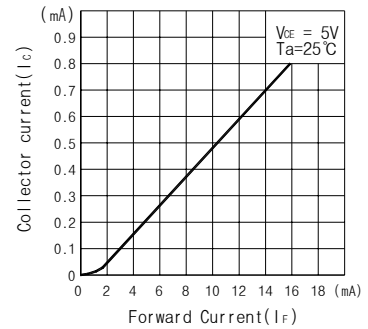

Collector Current Vs. Collector-Emitter Voltage

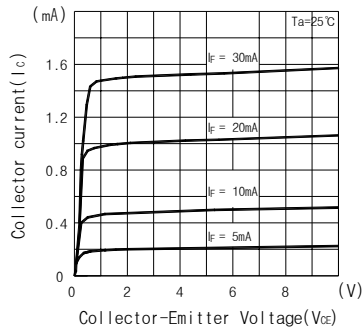

Relative Collector Current Vs. Ambient temperature

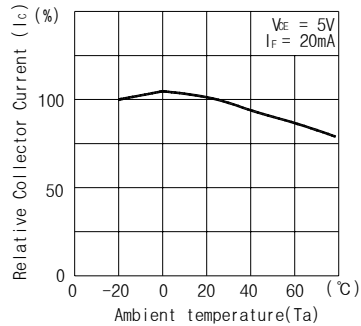

Collector Current Vs. Ambient temperature

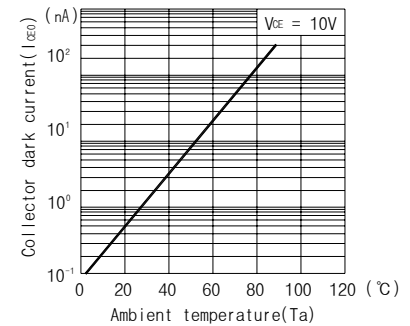

Switching time Vs. Load resistance

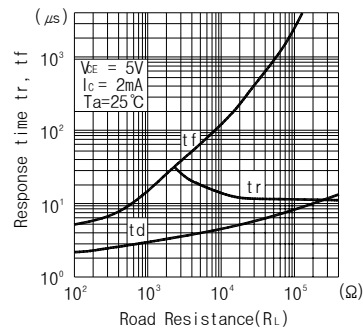

Relative Collector Current Vs. Moving distance

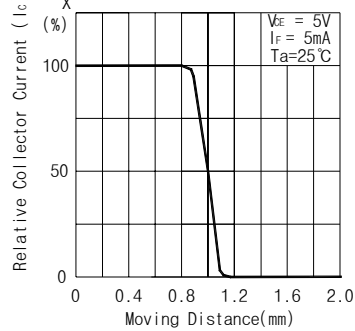

Relative Collector Current Vs. Moving distance

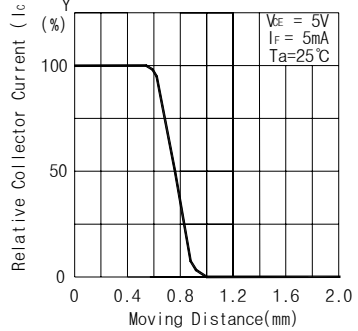

Switching time measurement circuit

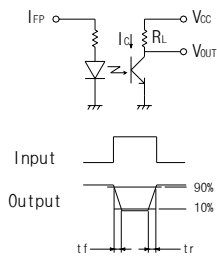

Method of measuring position detection characteristic

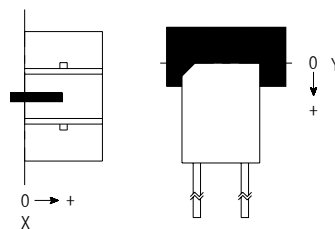

The contents of this data sheet are subject to change without advance notice for the purpose of improvement. When using this product, would you please refer to the latest specifications.

Package Outline Dimensions

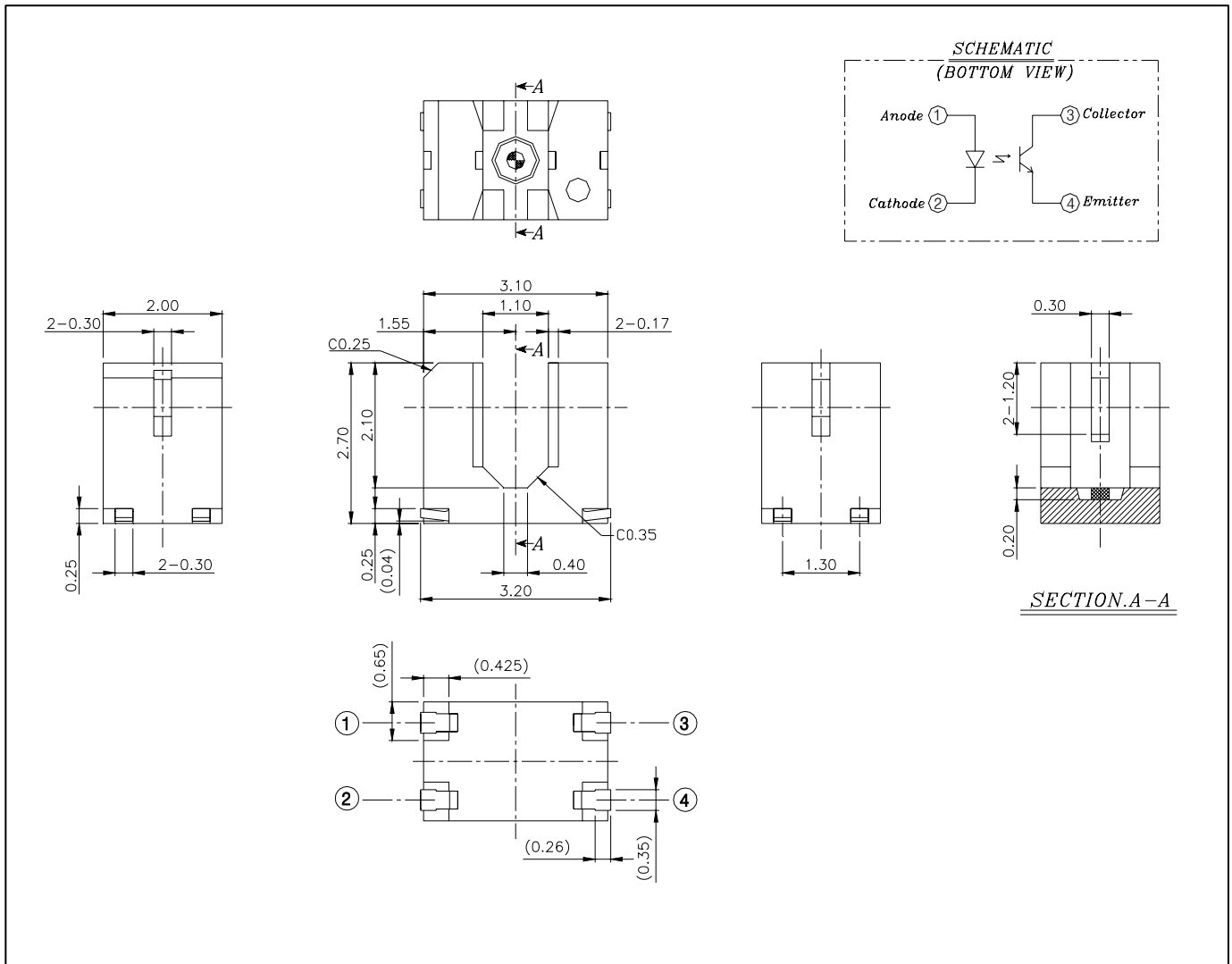

The contents of this data sheet are subject to change without advance notice for the purpose of improvement. When using this product, would you please refer to the latest specifications.