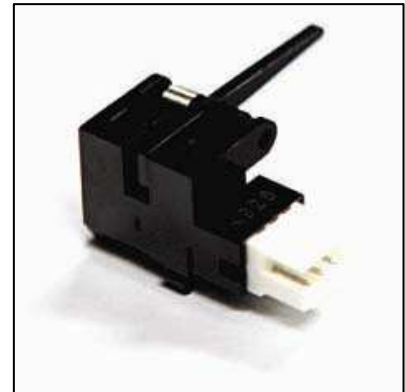

Photo Interrupter

KIA0005C

Description

The KIA0005C actuator type photo-interrupter combine high output GaAs IrED with high sensitive phototransistor and actuator, is ideal for copiers, facsimiles.



Features

- Snap in mount.
- Connector type.
- Widely applicable.
- RoHS compliant.



Applications

- Banking machines.
- Copiers.
- Printers.
- Facsimiles.

Absolute Maximum Ratings (T_a=25°C, Unless otherwise specified)

Characteristic		Symbol	Ratings	Unit
Input	Power Dissipation	PD	100	mW
	Forward Current	IF	60	mA
	Reverse Voltage	VR	5	V
	Pulse forward current ※1	IFP	1	A
Output	Collector Power Dissipation	PC	100	mW
	Collector Current	IC	40	mA
	Collector-Emitter Voltage	BVCEO	30	V
	Emitter-Collector Voltage	BVECO	5	V
Operating Temperature ※2		Topr.	-25 ~ 85	°C
Storage Temperature ※2		Tstg.	-40 ~ 85	°C
ESD Withstand Voltage(Human Body Model)		VESD.	±2.0	kV

Notes : ※1. Input current with $t_w = 100\mu s$, Period(T) = 10ms.

2. No icebound or dew.

The contents of this data sheet are subject to change without advance notice for the purpose of improvement. When using this product, would you please refer to the latest specifications.

Electrical Characteristics (T_a=25°C)

Characteristic		Symbol	Min	Typ	Max	Unit	Condition
Input	Forward voltage	V _F	-	1.2	1.7	V	I _F = 20mA
	Reverse Current	I _R	-	-	10	μA	V _R = 5V
	Capacitance	C _T	-	25	-	pF	f = 1kHz
	Peak wavelength	λ _P	-	940	-	nm	-
Output	Collector Dark Current	I _{CEO}	-	1	100	nA	V _{CE} = 10V, 0 Lux
Transmission	Collector Current	I _c	3.0	-	20	mA	V _{CE} = 5V, I _F =20mA (Non-Shading)
	Leakage Current	I _{CEOD}	-	-	20	μA	V _{CE} = 5V, I _F =20mA (Shading)
	Collector-Emitter Saturation Voltage	V _{CE(Sat)}	-	0.15	0.4	V	I _F =20mA, I _c =0.1mA
Response Time	Rise Time	t _r	-	5	-	μs	V _{CC} =5V, I _c = 2 mA R _L = 100Ω
	Fall Time	t _f	-	4	-	μs	

● Circuit for Measuring Response Time

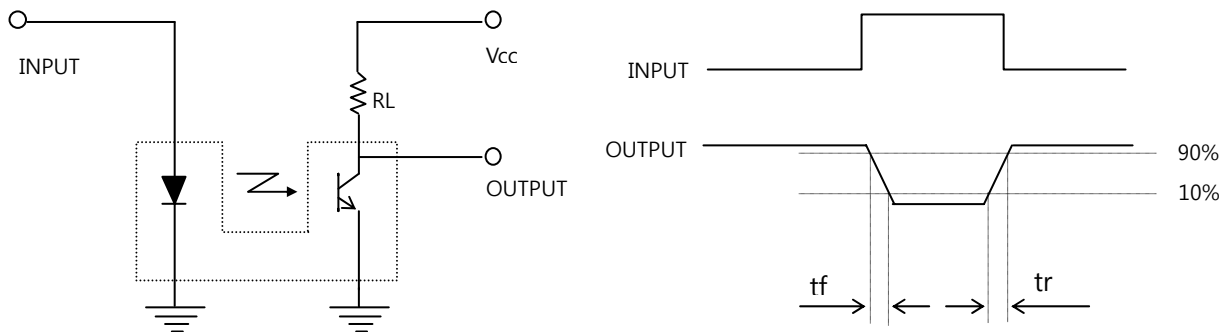

The contents of this data sheet are subject to change without advance notice for the purpose of improvement. When using this product, would you please refer to the latest specifications.

Electrical and optical characteristic curves

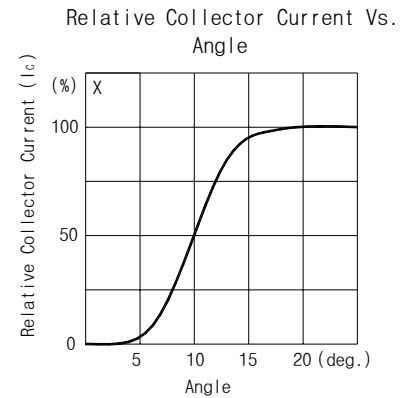
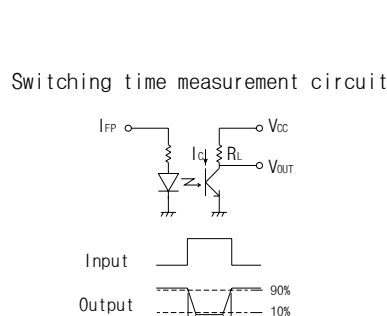
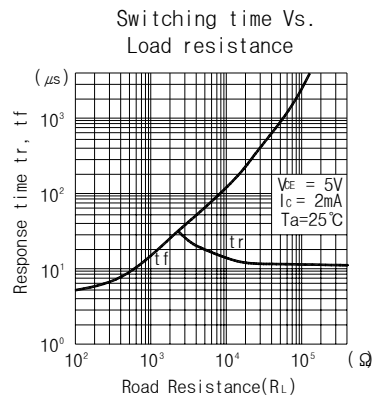
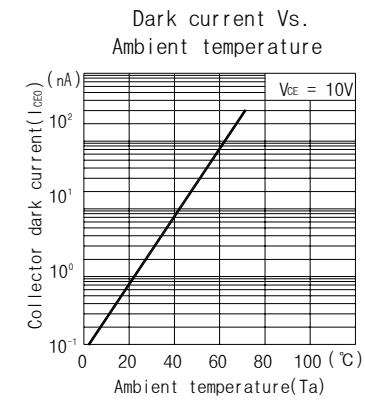
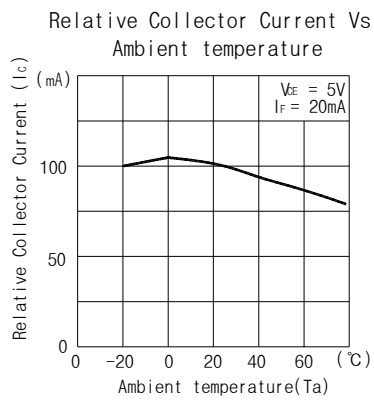
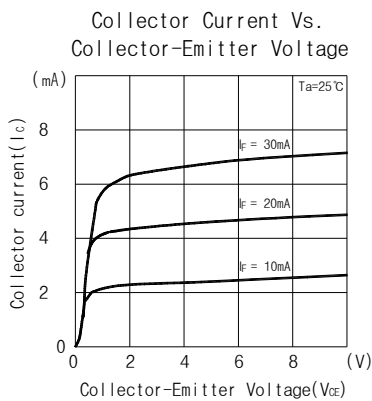
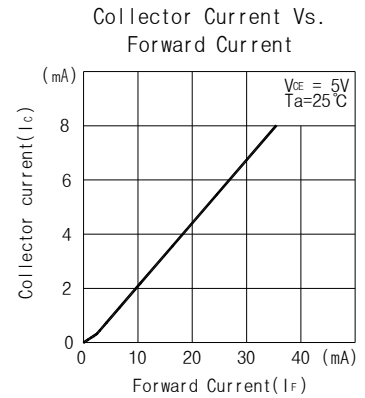
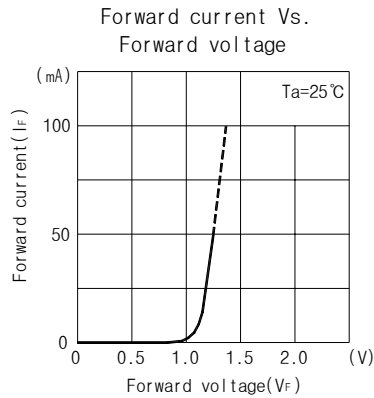
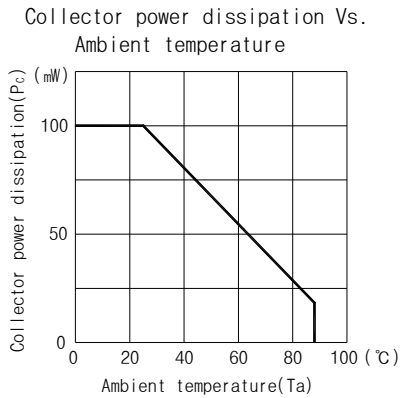

The contents of this data sheet are subject to change without advance notice for the purpose of improvement. When using this product, would you please refer to the latest specifications.

Package Outline Dimensions

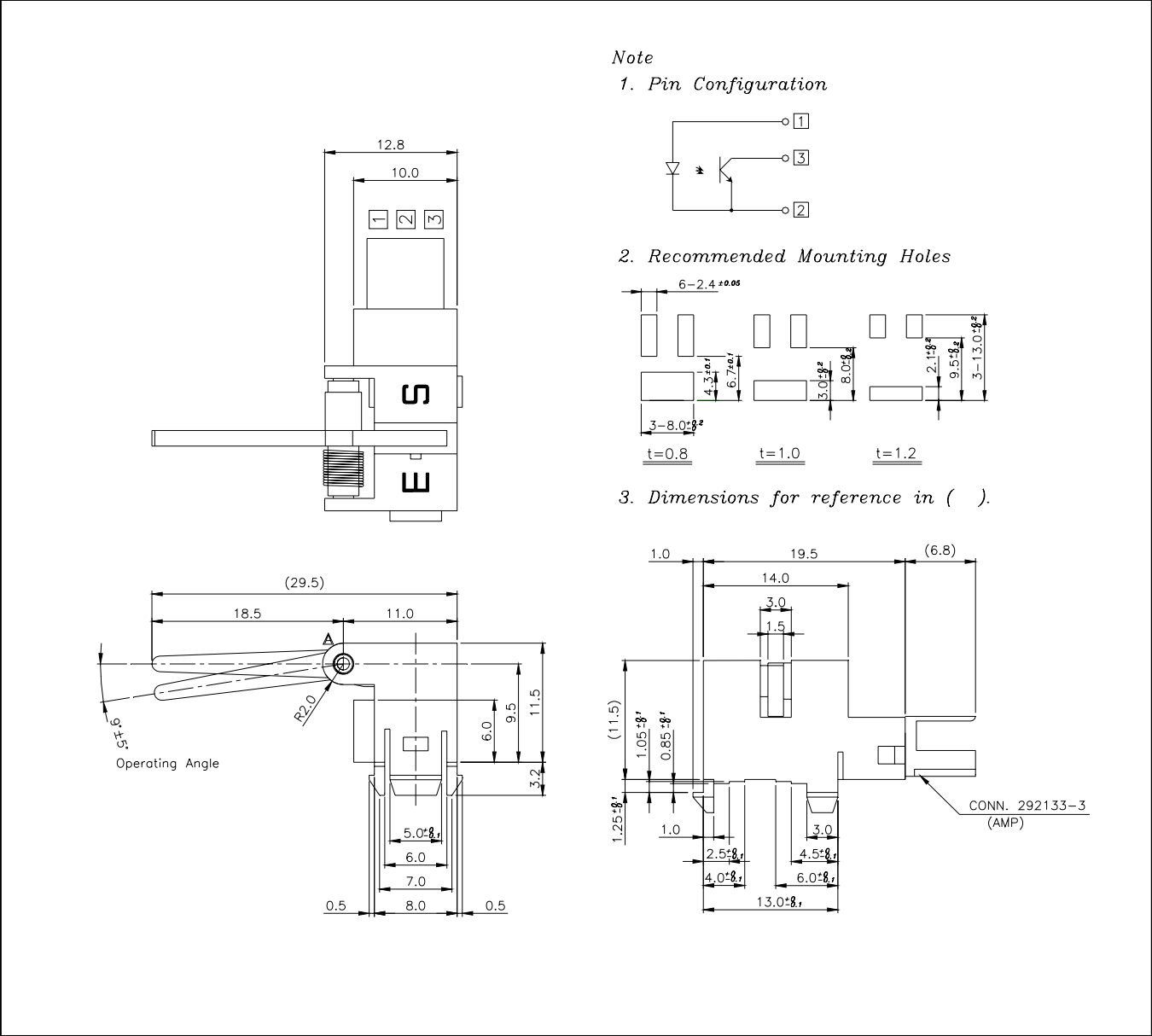

The contents of this data sheet are subject to change without advance notice for the purpose of improvement. When using this product, would you please refer to the latest specifications.